

# General Purpose Transistors

## PNP Silicon

- We declare that the material of product compliance with RoHS requirements.

### ORDERING INFORMATION

Device	Marking	Shipping
LMBT3906LT1G	2A	3000/Tape & Reel
LMBT3906LT3G	2A	10000/Tape & Reel

### LMBT3906LT1G

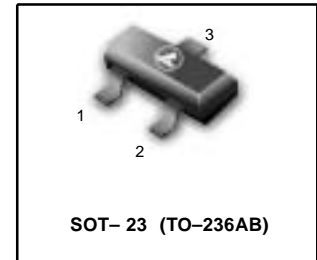

### MAXIMUM RATINGS

Rating	Symbol	Value	Unit
Collector–Emitter Voltage	$V_{CEO}$	- 40	Vdc
Collector–Base Voltage	$V_{CBO}$	- 40	Vdc
Emitter–Base Voltage	$V_{EBO}$	- 5.0	Vdc
Collector Current — Continuous	$I_C$	- 200	mAdc

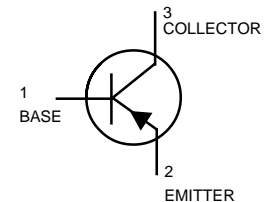

### THERMAL CHARACTERISTICS

Characteristic	Symbol	Max	Unit
Total Device Dissipation FR-5 Board(1) $T_A = 25^\circ\text{C}$	$P_D$	225	mW
Derate above $25^\circ\text{C}$		1.8	mW/ $^\circ\text{C}$
	$\theta_{JA}$	556	$^\circ\text{C}/\text{W}$
Total Device Dissipation Alumina Substrate, (2) $T_A = 25^\circ\text{C}$	$P_D$	300	mW
Derate above $25^\circ\text{C}$		2.4	mW/ $^\circ\text{C}$
Thermal Resistance Junction to Ambient	$R_{\theta JA}$	417	$^\circ\text{C}/\text{W}$
Junction and Storage Temperature	$T_J, T_{stg}$	-55 to +150	$^\circ\text{C}$

### DEVICE MARKING

LMBT3906LT1G = 2A

### ELECTRICAL CHARACTERISTICS ( $T_A = 25^\circ\text{C}$ unless otherwise noted)

Characteristic	Symbol	Min	Max	Unit
----------------	--------	-----	-----	------

### OFF CHARACTERISTICS

Collector–Emitter Breakdown Voltage (3) ( $I_C = -1.0\text{ mAdc}, I_B = 0$ )	$V_{(BR)CEO}$	- 40	—	Vdc
Collector–Base Breakdown Voltage ( $I_C = -10\ \mu\text{Adc}, I_E = 0$ )	$V_{(BR)CBO}$	- 40	—	Vdc
Emitter–Base Breakdown Voltage ( $I_E = -10\ \mu\text{Adc}, I_C = 0$ )	$V_{(BR)EBO}$	- 5.0	—	Vdc
Base Cutoff Current ( $V_{CE} = -30\text{ Vdc}, V_{EB} = -3.0\text{ Vdc}$ )	$I_{BL}$	—	- 50	nAdc
Collector Cutoff Current ( $V_{CE} = -30\text{ Vdc}, V_{EB} = -3.0\text{ Vdc}$ )	$I_{CEX}$	—	- 50	nAdc

- FR-5 =  $1.0 \times 0.75 \times 0.062$  in.
- Alumina =  $0.4 \times 0.3 \times 0.024$  in. 99.5% alumina.
- Pulse Width  $\leq 300\ \mu\text{s}$ ; Duty Cycle  $\leq 2.0\%$ .

**LMBT3906LT1G**
**ELECTRICAL CHARACTERISTICS** ( $T_A = 25^\circ\text{C}$  unless otherwise noted) (Continued)

Characteristic	Symbol	Min	Max	Unit
<b>ON CHARACTERISTICS (2)</b>				
DC Current Gain ( $I_C = -0.1 \text{ mA}$ , $V_{CE} = -1.0 \text{ Vdc}$ )	$h_{FE}$	60	—	—
( $I_C = -1.0 \text{ mA}$ , $V_{CE} = -1.0 \text{ Vdc}$ )		80	—	—
( $I_C = -10 \text{ mA}$ , $V_{CE} = -1.0 \text{ Vdc}$ )		100	300	—
( $I_C = -50 \text{ mA}$ , $V_{CE} = -1.0 \text{ Vdc}$ )		60	—	—
( $I_C = -100 \text{ mA}$ , $V_{CE} = -1.0 \text{ Vdc}$ )		30	—	—
Collector–Emitter Saturation Voltage ( $I_C = -10 \text{ mA}$ , $I_B = -1.0 \text{ mA}$ )	$V_{CE(sat)}$	—	-0.25	Vdc
( $I_C = -50 \text{ mA}$ , $I_B = -5.0 \text{ mA}$ )		—	-0.4	—
Base–Emitter Saturation Voltage ( $I_C = -10 \text{ mA}$ , $I_B = -1.0 \text{ mA}$ )	$V_{BE(sat)}$	-0.65	-0.85	Vdc
( $I_C = -50 \text{ mA}$ , $I_B = -5.0 \text{ mA}$ )		—	-0.95	—

**SMALL-SIGNAL CHARACTERISTICS**

Current–Gain — Bandwidth Product ( $I_C = -10 \text{ mA}$ , $V_{CE} = -20 \text{ Vdc}$ , $f = 100 \text{ MHz}$ )	$f_T$	250	—	MHz
Output Capacitance ( $V_{CB} = -5.0 \text{ Vdc}$ , $I_E = 0$ , $f = 1.0 \text{ MHz}$ )	$C_{obo}$	—	4.5	pF
Input Capacitance ( $V_{EB} = -0.5 \text{ Vdc}$ , $I_C = 0$ , $f = 1.0 \text{ MHz}$ )	$C_{ibo}$	—	10	pF
Input Impedance ( $V_{CE} = -10 \text{ Vdc}$ , $I_C = -1.0 \text{ mA}$ , $f = 1.0 \text{ kHz}$ )	$h_{ie}$	2.0	12	k $\Omega$
Voltage Feedback Ratio ( $V_{CE} = -10 \text{ Vdc}$ , $I_C = -1.0 \text{ mA}$ , $f = 1.0 \text{ kHz}$ )	$h_{re}$	0.1	10	$\times 10^{-4}$
Small–Signal Current Gain ( $V_{CE} = -10 \text{ Vdc}$ , $I_C = -1.0 \text{ mA}$ , $f = 1.0 \text{ kHz}$ )	$h_{re}$	100	400	—
Output Admittance ( $V_{CE} = -10 \text{ Vdc}$ , $I_C = -1.0 \text{ mA}$ , $f = 1.0 \text{ kHz}$ )	* $h_{oe}$	3.0	60	$\mu\text{mhos}$
Noise Figure ( $V_{CE} = -5.0 \text{ Vdc}$ , $I_C = -100 \mu\text{A}$ , $R_s = 1.0 \text{ k}\Omega$ , $f = 1.0 \text{ kHz}$ )	NF	—	4.0	dB

**SWITCHING CHARACTERISTICS**

Delay Time	$(V_{CC} = -3.0 \text{ Vdc}, V_{BE} = 0.5 \text{ Vdc}, I_C = -10 \text{ mA}, I_{B1} = -1.0 \text{ mA})$	$t_d$	—	35	ns
Rise Time		$t_d$	—	35	
Storage Time	$(V_{CC} = -3.0 \text{ Vdc}, I_C = -10 \text{ mA}, I_{B1} = I_{B2} = -1.0 \text{ mA})$	$t_s$	—	225	ns
Fall Time		$t_f$	—	75	

 3. Pulse Test: Pulse Width  $\leq 300 \mu\text{s}$ ; Duty Cycle  $\leq 2.0\%$ .

**LMBT3906LT1G**

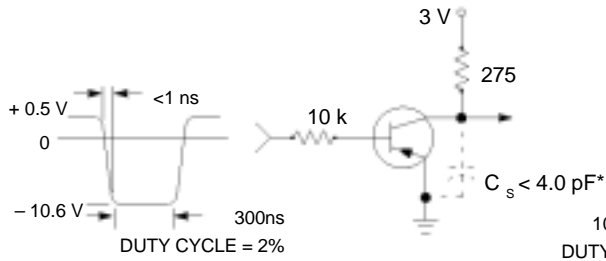

**Figure 1. Delay and Rise Time  
Equivalent Test Circuit**

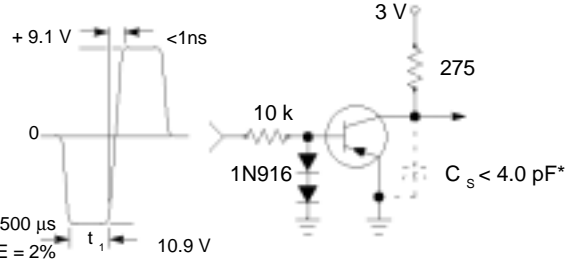

**Figure 2. Storage and Fall Time  
Equivalent Test Circuit**

\*Total shunt capacitance of test jig and connectors

**TYPICAL TRANSIENT CHARACTERISTICS**

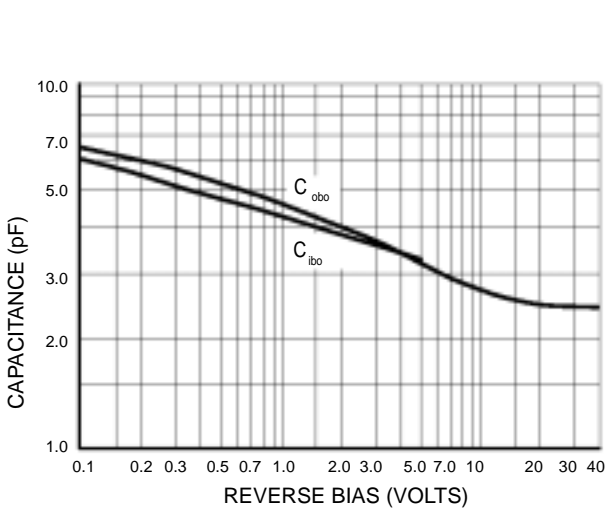

**Figure 3. Capacitance**

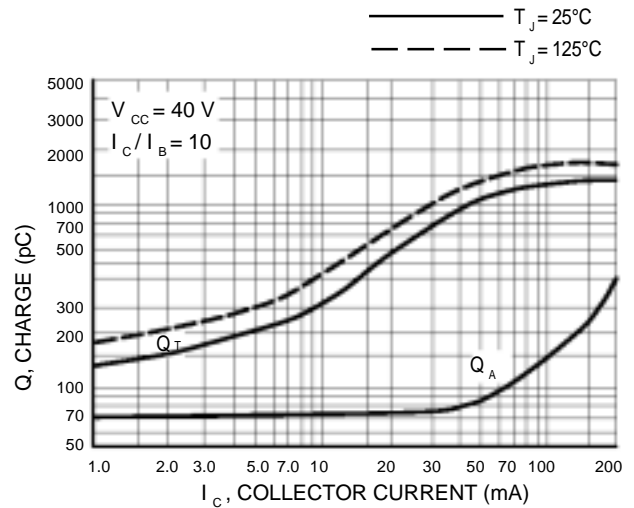

**Figure 4. Charge Data**

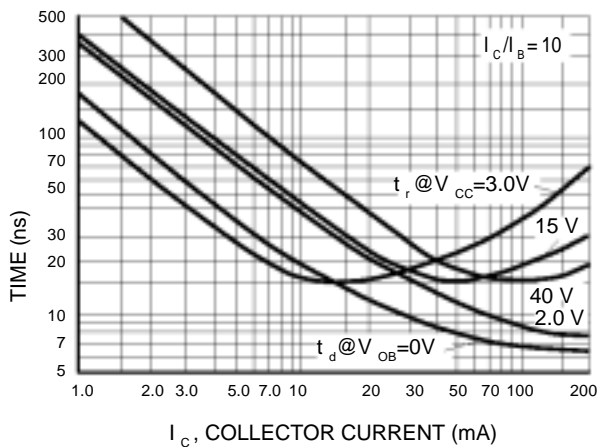

**Figure 5. Turn-On Time**

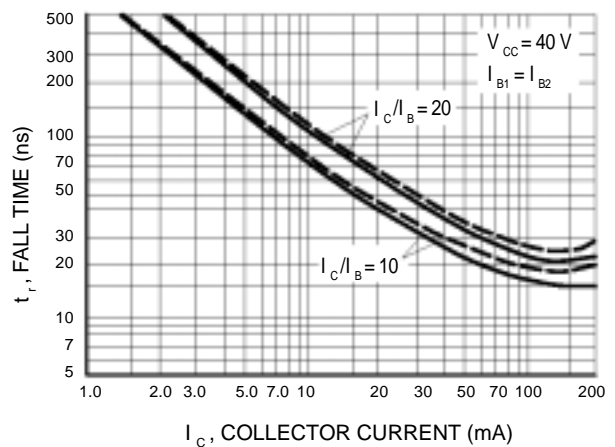
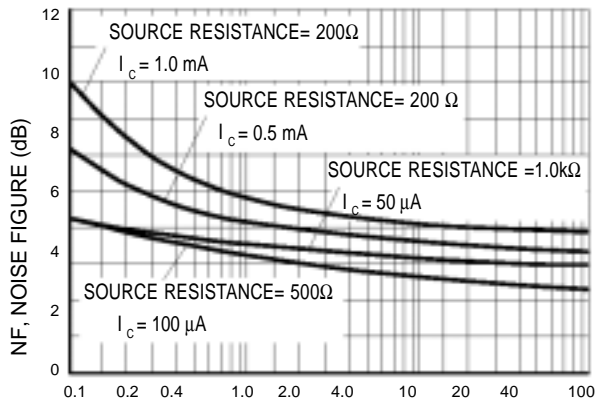

**Figure 6. Fall Time**

**LMBT3906LT1G**

**TYPICAL AUDIO SMALL-SIGNAL CHARACTERISTICS  
NOISE FIGURE VARIATIONS**

( $V_{CE} = -5.0$  Vdc,  $T_A = 25^\circ\text{C}$ , Bandwidth = 1.0 Hz)



f, FREQUENCY (kHz)  
**Figure 7. Noise Figure**

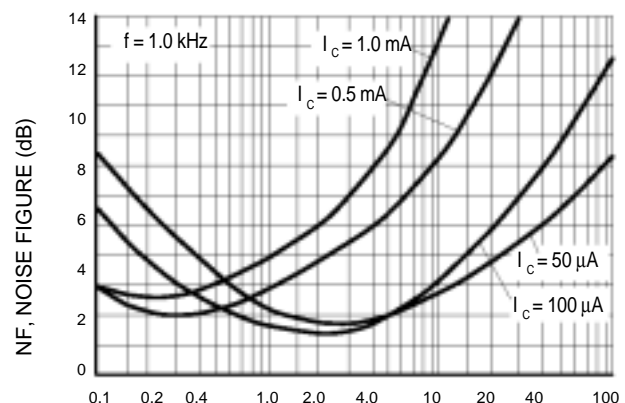

$R_g$ , SOURCE RESISTANCE (k $\Omega$ )  
**Figure 8. Noise Figure**

**h PARAMETERS**

( $V_{CE} = 10$  Vdc,  $f = 1.0$  kHz,  $T_A = 25^\circ\text{C}$ )

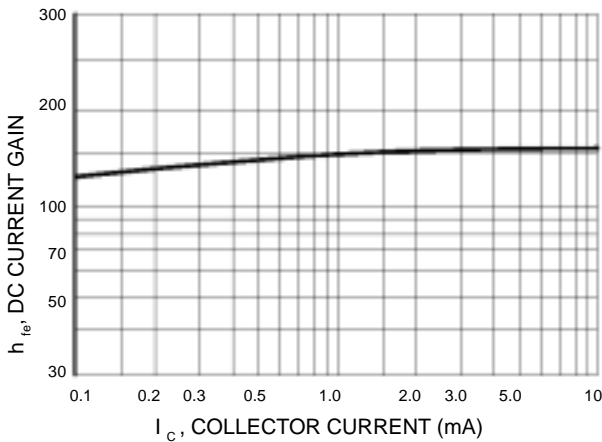

$I_C$ , COLLECTOR CURRENT (mA)  
**Figure 9. Current Gain**

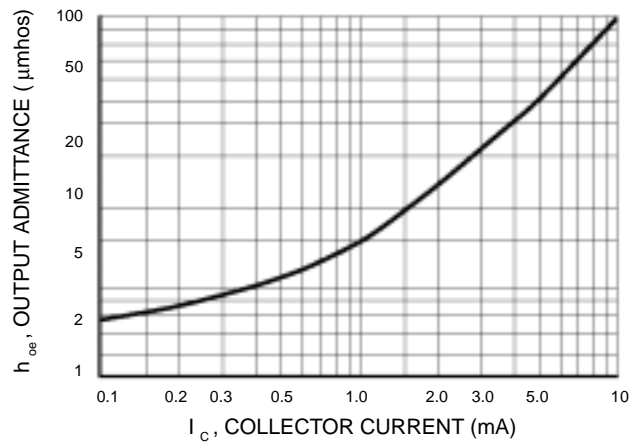

$I_C$ , COLLECTOR CURRENT (mA)  
**Figure 10. Output Admittance**

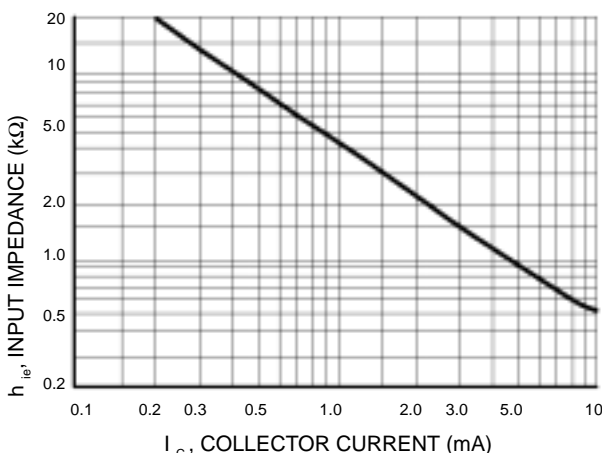

$I_C$ , COLLECTOR CURRENT (mA)  
**Figure 11. Input Impedance**

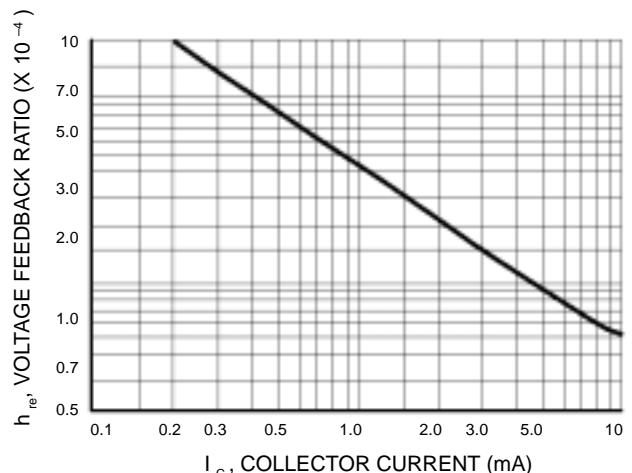

$I_C$ , COLLECTOR CURRENT (mA)  
**Figure 12. Voltage Feedback Ratio**

**LMBT3906LT1G**

**TYPICAL STATIC CHARACTERISTICS**

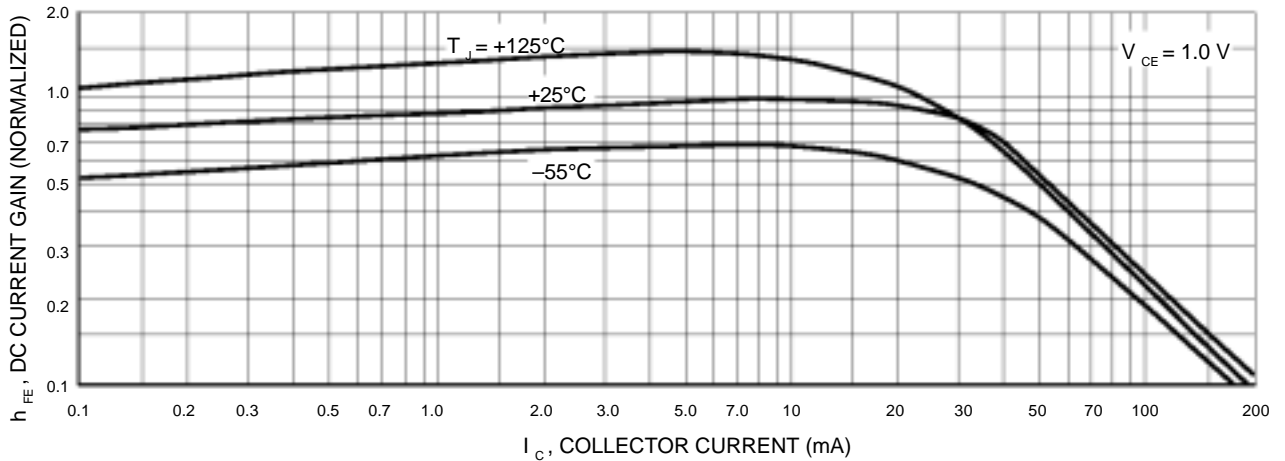

**Figure 13. DC Current Gain**

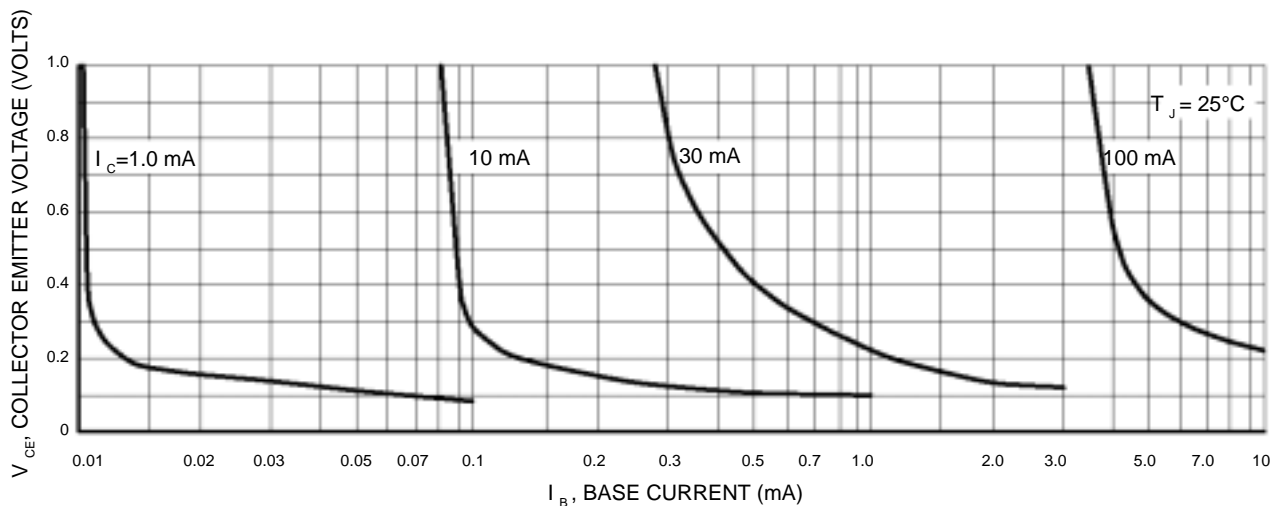

**Figure 14. Collector Saturation Region**

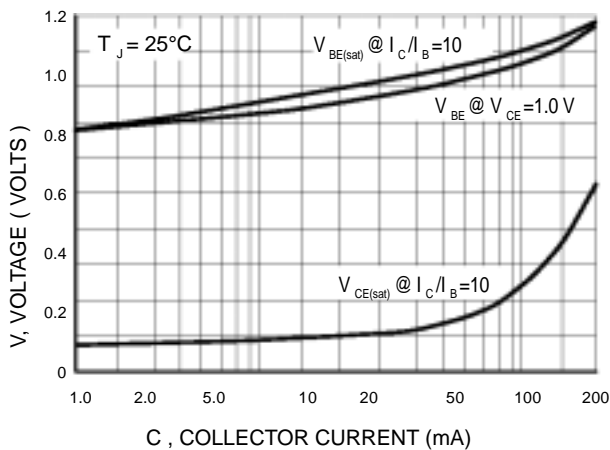

**Figure 15. "ON" Voltages**

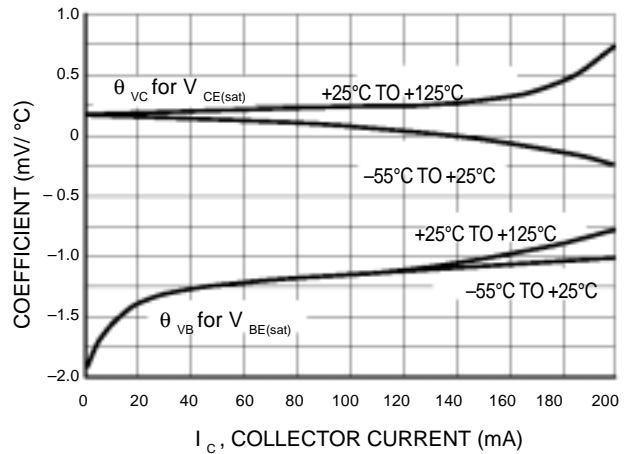

**Figure 16. Temperature Coefficients**

**LMBT3906LT1G**

**SOT-23**

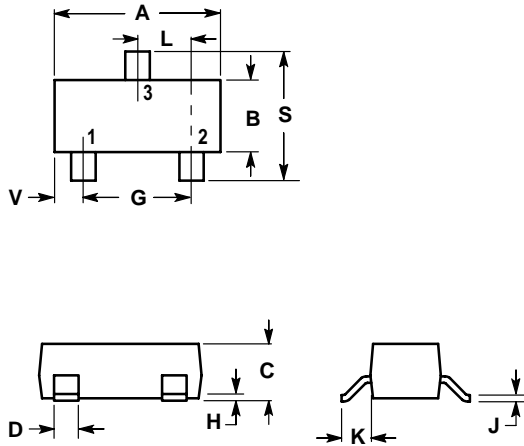

NOTES:

1. DIMENSIONING AND TOLERANCING PER ANSI Y14.5M, 1982.
2. CONTROLLING DIMENSION: INCH.

DIM	INCHES		MILLIMETERS	
	MIN	MAX	MIN	MAX
A	0.1102	0.1197	2.80	3.04
B	0.0472	0.0551	1.20	1.40
C	0.0350	0.0440	0.89	1.11
D	0.0150	0.0200	0.37	0.50
G	0.0701	0.0807	1.78	2.04
H	0.0005	0.0040	0.013	0.100
J	0.0034	0.0070	0.085	0.177
K	0.0140	0.0285	0.35	0.69
L	0.0350	0.0401	0.89	1.02
S	0.0830	0.1039	2.10	2.64
V	0.0177	0.0236	0.45	0.60

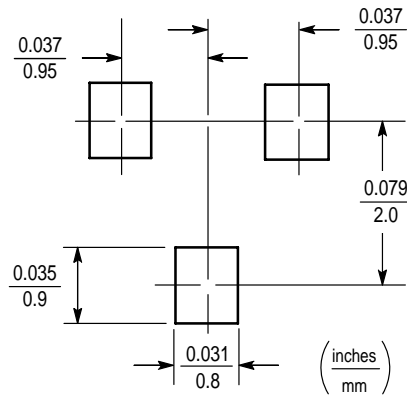

## EMBOSSED TAPE AND REEL DATA FOR DISCRETES

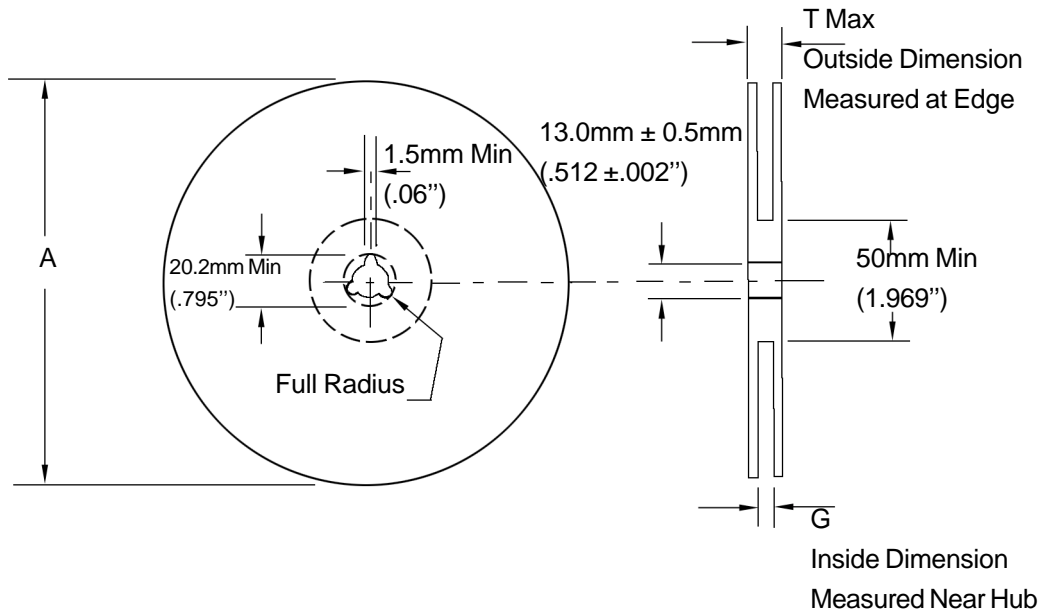

Size	A Max	G	T Max
8 mm	330mm (12.992")	8.4mm+1.5mm, -0.0 (.33"+.059", -0.00)	14.4mm (.56")

### Reel Dimensions

Metric Dimensions Govern — English are in parentheses for reference only

### Storage Conditions

Temperature: 5 to 40 Deg.C (20 to 30 Deg. C is preferred)

Humidity: 30 to 80 RH (40 to 60 is preferred )

Recommended Period: One year after manufacturing

(This recommended period is for the soldering condition only. The characteristics and reliabilities of the products are not restricted to this limitation)

## Shipment Specification

