

NO.	DESCRIPTION	PART NO.	QTY	MATERIAL	DRW NO.	REMARKS
1	CONNECTOR	10 5805 XXX 00X 829 +	2000			
2	EMBOSSED TAPE		1	POLYSTYRENE		
3	TOP COVER TAPE		1	POLYSTYRENE		
4	REEL		1	POLYSTYRENE		

極数 NO. OF POS.	A	B	C	D
10	5.5	-	12	18.4
16	7.5	-	16	22.4
20	7.5	-	16	22.4
24	7.5	-	16	22.4
26	7.5	-	16	22.4
30	7.5	-	16	22.4
34	11.5	-	24	30.4
40	11.5	-	24	30.4
44	11.5	-	24	30.4
50	11.5	-	24	30.4
54	11.5	-	24	30.4
60	11.5	-	24	30.4
64	11.5	-	24	30.4
70	11.5	-	24	30.4
80	14.2	28.4	32	38.4

注記
NOTE

- 梱包数量 : 2000 個/リール
PACKING QUANTITY : 2000 ea/reel
- 納入時のリール巻き方向
REELING DIRECTION
IN DELIVERY

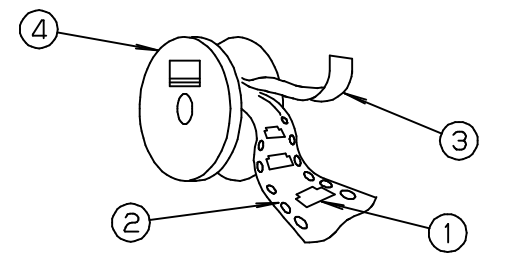

- 引出し方向
USER DIRECTION OF FEED

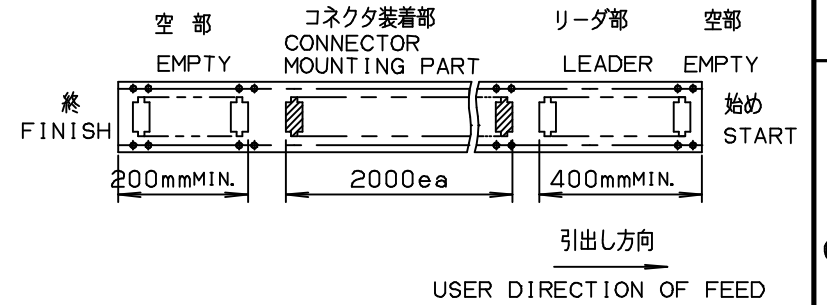

- 型番
P/N 14 5805 XXX 00X 829 +

極数
NO. OF POS.
バリエーション
VARIATION

	ANCHOR PLATE	BOSS	GUIDE POST
0	-	-	-
1	-	◎	-

◎: WITH - : WITHOUT

TOLERANCE / 一般公差 (S)		PRODUCT SPEC / 製品規格							
X < 10	±0.2			A	DCN-809	6-15-05			
10 ≤ X < 30	±0.25	UNIT	ANGLE	O	EDN-365	3-25-05	T. SASAKI	H. TAGUCHI	N. HAYASHI
30 ≤ X	±0.3	mm	3RD	NO.	EDN/DCN	DATE	ISSUE	CHECKED	APPROVED
ANGLE / 角度	±3°	SCALE	DATE	PART NAME / 品名					
		3/1	3-25-05	SERIES 5805 EMBOSS TAPE ASSY					
DRAWN		DESIGNED	CHECKED	APPROVED	PART NO. / 型番				
T. SASAKI		T. SASAKI	H. TAGUCHI	N. HAYASHI	14 5805 XXX 00X 829 +				
DWG NO. / 図番		KYOCERA		SHEET REV					
BJS 5805007		KYOCERA ELCO CORPORATION		1/1		A			

NO.	DESCRIPTION	PART NO.	QTY	MATERIAL	DRW NO.	REMARKS
1	INSULATOR		1	LCP		COLOR:BLACK
2	CONTACT		N	COPPER ALLOY		Au PLATING

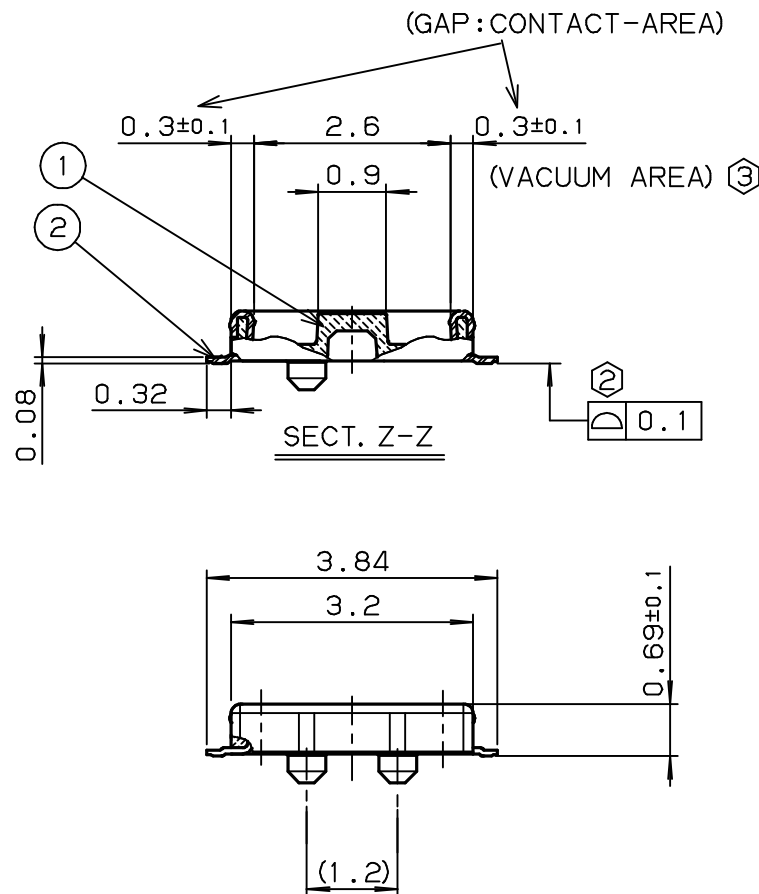
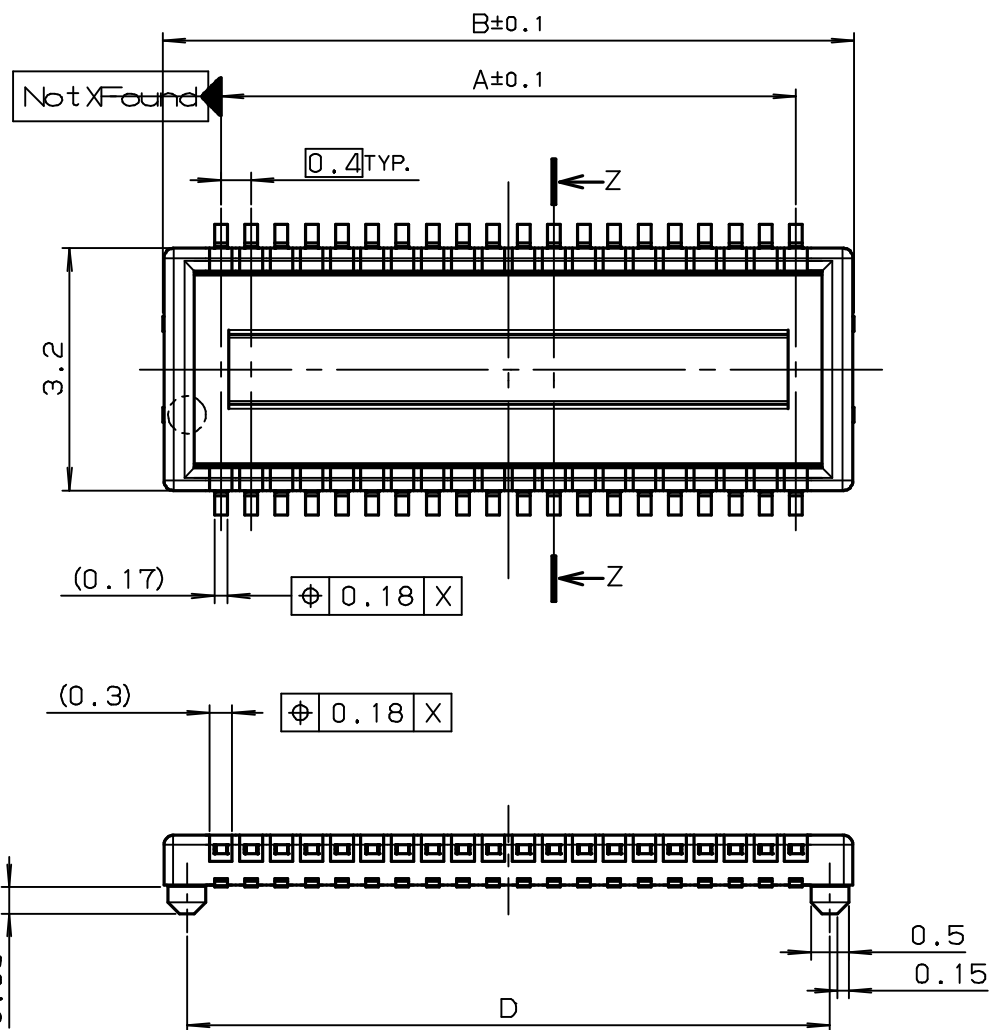

極数 NO. OF POS.	A	B	C	D
10	1.6	3.14	4.1	2.5
16	2.8	4.34	5.3	3.7
20	3.6	5.14	6.1	4.5
24	4.4	5.94	6.9	5.3
26	4.8	6.34	7.3	5.7
30	5.6	7.14	8.1	6.5
34	6.4	7.94	8.9	7.3
40	7.6	9.14	10.1	8.5
44	8.4	9.94	10.9	9.3
50	9.6	11.14	12.1	10.5
54	10.4	11.94	12.9	11.3
60	11.6	13.14	14.1	12.5
64	12.4	13.94	14.9	13.3
70	13.6	15.14	16.1	14.5
80	15.6	17.14	18.1	16.5

注記
NOTE

1. 型番
P/N 10 5805 XXX 00X 829 +

極数
NO. OF POS.

バリエーション
VARIATION

	ANCHOR PLATE	BOSS	GUIDE POST
0	-	-	-
1	-	◎	-

◎: WITH - : WITHOUT

②. テール及び金具底面の相互の輪郭度は、0.1mmMAX.
COPLANARITY OF CONTACT TAIL AND
ANCHOR PLATE IS 0.1mmMAX.

③. 凸凹無き事
FLAT KEEPING AREA

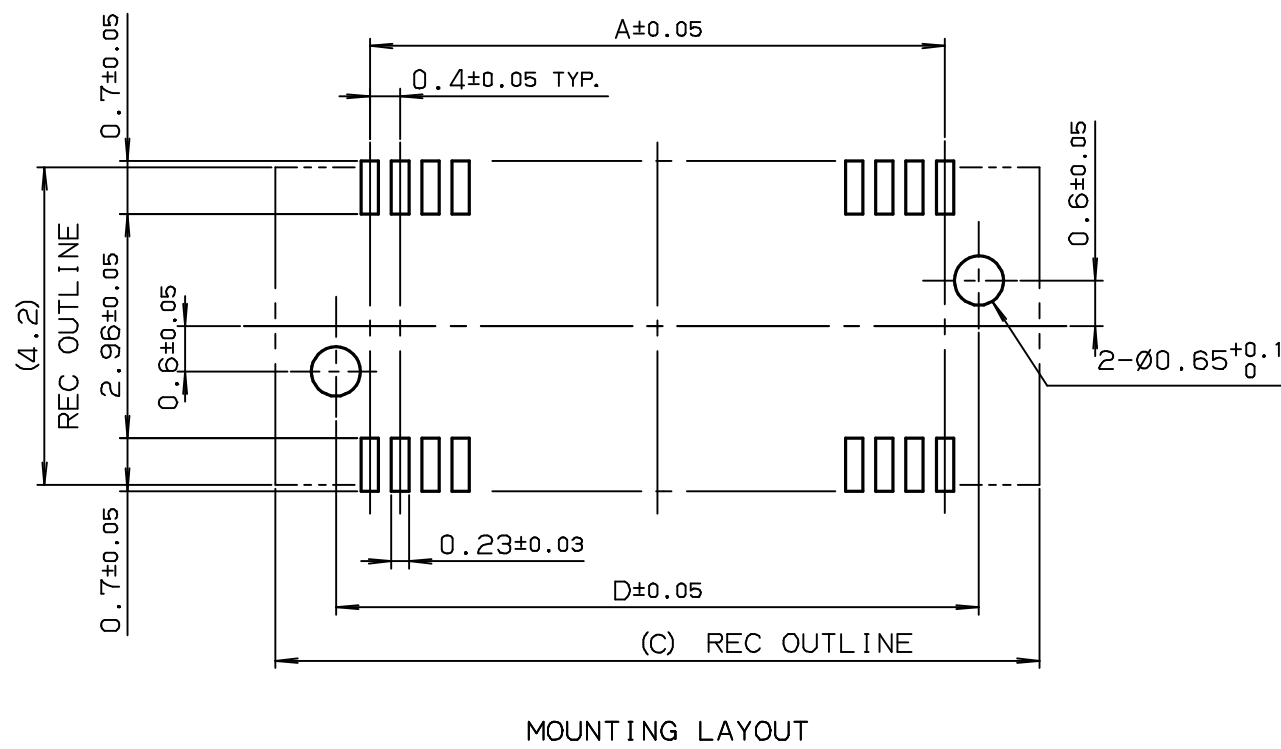

TOLERANCE / 一般公差 (S)		PRODUCT SPEC / 製品規格							
X < 10	±0.2			A	DCN-809	6-15-05			
10 ≤ X < 30	±0.25	UNIT	ANGLE	O	EDN-365	3-25-05	T. SASAKI	H. TAGUCHI	N. HAYASHI
30 ≤ X	±0.3	mm	3RD	NO.	EDN/DCN	DATE	ISSUE	CHECKED	APPROVED
ANGLE / 角度	±3°	SCALE	DATE	PART NAME / 品名					
		NJS	3-25-05	SERIES 5805 PLUG ASSY ST SMT 0.4mm PITCH BOARD TO BOARD H=1.0mm					
DRAWN	DESIGNED	CHECKED	APPROVED	PART NO. / 型番					
T. SASAKI	T. SASAKI	H. TAGUCHI	N. HAYASHI	10 5805 XXX 00X 829 +					
KYOCERA				DWG NO. / 図番		SHEET / REV			
KYOCERA ELCO CORPORATION				BJS 5805005		1/1		A	