



APPROVAL SHEET

Customer Information

Customer :			
Part Name :			
Part No. :			
Model No. :			
	COMPANY	PURCHASE	R&D

Vendor Information

Name:	HYLINK Technology CO.,LTD
Part Name	Chip TVS
Part No.	HL0402-050E560NP-LF
Lot No.	

HYLINK Technology CO.,LTD			
ADDRESS : No11,Xinke Road,Changzhou Electronical Technology Industrial Park, Changzhou New District,P.R.CHINA			
TEL: 0519- 8221008		FAX: 0519- 8221221	E-mail: sales @hylink.cn
Quality Control	Document Control		Business Issue
	REV:A		Prepared
			Check
			



PART NO. HLO402-050E560NP-LF

1.1 Technical Data

	Symbol	Value	Unit
Maximum allowable continuous AC voltage * ₁	V _{RMS}	3.3	V
Maximum allowable continuous DC voltage	V _{DC}	5	V
Varistor voltage Measured * ₂	V _V	15~25	V
Typical capacitance value measured * ₃	C	56	pF
Typical capacitance value tolerance		± 30	%
Maximum clamping voltage Measured * ₄	V _{CLAMP}	45	V

1.2 Reference Data

Maximum Energy Absorption * ₅	E	>	0.05	J
Response time	T _{rise}	<	0.5	ns
Leakage current at VDC(max)	I _{VV}	<	1	uA
Leakage current at VDC(max)(After reality Test)	I _{VVA}	<	2	uA
Operation ambient temperature			-55~+85	
Storage temperature			-55~+125	
Reflow solder profile temperature(Recommend)			250	

1.3 Other Data

Body			ZnO	
End termination			Ag/Ni/Sn	
Packaging			Reel	
Complies with Standard			IEC61000-4-2	
Marking			None	
Lead content		<	1000	ppm

Notes:

- * 1 AC voltage at 50~60 Hz
- * 2 Varistor voltage
- * 3 Capacitance
- * 4 Maximum clamping voltage
- * 5 Testing condition :8x20us waveform

Measured at 1mA DC
 Measured at f = 1MHz, Vrms = 0.5 V
 Measured at 1A by 8 / 20us Pulse

2 .Size

Model	0402(1005)
Length(L)	1.00 ±0.10
Width(W)	0.50 ±0.10
Thickness(T)	0.60 max





3.ESD Wave Form

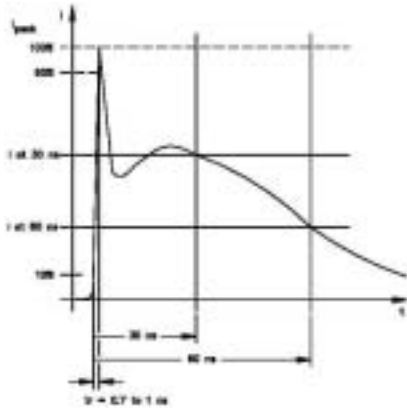

IEC61000-4-2 Standards

SEVERITY LEVEL	AIRDIRCHARGE	DIRECT DISCHARGE
1	2 KV	2 KV
2	4 KV	4 KV
3	8 KV	6 KV
4	15 KV	8 KV

IEC 61000-4-2 Compliant ESD Current Pulse Waveform

4. Enviromental Reliability Test

Characteristic	Test method and description			
High Temperature Storage	The specimen shall be subjected to 150 ± 2 for 1000 ± 12 hours in a thermostatic bath without load and then stored at room temperature and humidity for 1 to 2 hours. The change of varistor voltage shall be within 10 %.			
Temperature Cycle	The temperature cycle of specified temperature shall be repeated five times and then stored at room temperature and humidity for one or two hours. The change of varistor voltage shall be within 10 % and mechanical damage shall be examined.	Step	Temperature	Period
		1	-55 ± 3	30Min ± 3
		2	Room Temperature	1~2 hours
		3	125 ± 2	30Min ± 3
4	Room Temperature	1~2 hours		
High Temperature Load	After being continuously applied the maximum allowable voltage at 85 ± 2 for 1000 ± 2 hours, the specimen shall be stored at room temperature and humidity for one or two hours, the change of varistor voltage shall be within 10%.			
Damp Heat Load/ Humidity Load	The specimen should be subjected to 40 ± 2 , 90 to 95 %RH environment, and the maximum allowable voltage applied for 1000 hours, then stored at room temperature and humidity for one or two hours. The change of varistor voltage shall be within 10%			
Low Temperature Storage	The specimen should be subjected to -55 ± 2 , without load for 500 hours and then stored at room temperature for one or two hours. the change of varistor voltage shall be within 10%.			



5. Soldering Recommendations

5.1 Recommended solder pad layout

(Unit:mm)

	A	B	C	D
0402	0.4~0.6	1.4~1.8	0.5~0.6	0.6~1.2
0603	0.8~1.2	2.2~2.8	0.6~1.0	0.9~1.5
0805	1.0~1.5	2.6~3.2	1.2~1.5	1.1~1.8
1206	1.8~2.5	4.2~5.2	1.2~1.8	1.2~1.8
1210	1.8~2.5	4.2~5.2	2.2~3.0	1.3~2.0
1812	2.5~3.3	5.5~6.7	2.8~3.6	1.3~2.2
2220	3.8~4.6	6.6~7.8	4.8~5.5	1.3~2.2

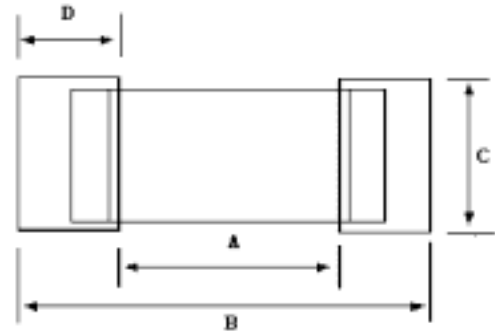

5.2 The SIR test of the solder paste shall be done(Based on JIS-Z-3284)

5.3 Steel plate and foot distance printing

Foot distance printing (mm)	Steel Plate thickness (mm)
> 0.65mm	0.18mm
0.65mm~0.5mm	0.15mm
0.50mm~0.40mm	0.12mm
<=0.40 mm	0.10mm

5.4 The IR reflow and temperature of Soldering for Pb Free

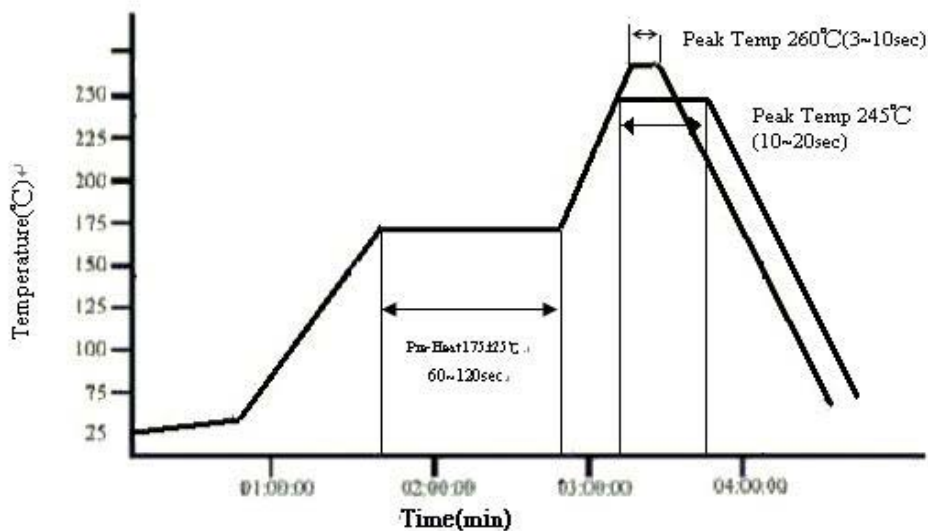

IR reflow Pb Free Process suggestion profile

- (1) The solder recommend is Sn96.5/Ag 3.5 of 120 to 150μm
- (2) Ramp-up rate (217 to Peak) + 3 /second max
- (3) Temp. maintain at 175 +/-25 180 seconds max
- (4) Temp. maintain above 217 60-150 seconds



(5) Peak temperature range 245 +20 -10 time within 5 of actually peak temperature (tp)
10~20 seconds

(6) Ramp down rate +6 /second max.

Perform adequate test in advance as the reflow temperature profile will vary according to the conditions of the manufacturing process, and the specification of the reflow furnace.

5.5 Resistance to soldering heat-High Temperature Resistance:260 ,10sec-3times.

5.6 Hand Soldering

In hand soldering of the Varistors. Large temperature gradient between preheated the Varistors and the tip of soldering iron may cause electrical failures and mechanical damages such as crackings or breakings of the devices. The soldering shall be carefully controlled and carried out so that the temperature gradient is kept minimum with following recommended conditions for hand soldering.

5.6.1 Recommended Soldering Condition 1

(1) Solder:

0.12~0.18mm Thread solder (**Sn96.5:Ag3.5**) with soldering flux in the core.

Rosin-based and non-activated flux is recommended.

(2) Preheating

The Varistors shall be preheated so that Temperature Gradient between the devices and the tip of soldering iron is 150 or below.

(3) Soldering Iron

Rated Power of 20w max with 3mm soldering tip in diameter.

Temperature of soldering iron tip 380 max,3-5sec (The required amount of solder shall be melted in advance on the soldering tip.)

(4) Cooling

After soldering. The Varistors shall be cooled gradually at room ambient temperature.

5.6.2 Recommended Soldering Condition 2(Without preheating)

(1) Solder iron tip shall not directly touch to ceramic dielectrics.

(2) Solder iron tip shall be fully preheated before soldering while soldering iron tip to the external electrode of Varistors.

5.7 Post Soldering Cleaning

5.7.1 Residues of corrosive soldering fluxes on the PC board after cleaning may greatly have influences on the electrical characteristic and the reliability (such as humidity resistance)of the Varistors which have been mounted on the board. It shall be confirmed that the characteristic and the reliability of the devices are not affected by the applied cleaning conditions.

5.7.2. When an ultrasonic cleaning is applied to the mounted Varistors on PC Boards. Following conditions are recommended for preventing failures or damages of the devices due to the large vibration energy and the resonance caused by the ultrasonic waves.

(1) Frequency 29MHz max

(2) Radiated Power 20w/lithr max

(3) Period 5minuets max



6. Packaging Specification

- 6.1 Carrier tape and transparent cover tape should be heat-sealed to carry the products, and the reel should be used to reel the carrier tape.
- 6.2 The adhesion of the heat-sealed cover tape shall be 40 +20/ -15grams.
- 6.3 Both the head and the end portion of the taping shall be empty for reel package and SMT auto-pickup machine. And a normal paper tape shall be connected in the head of taping for the operator to handle.

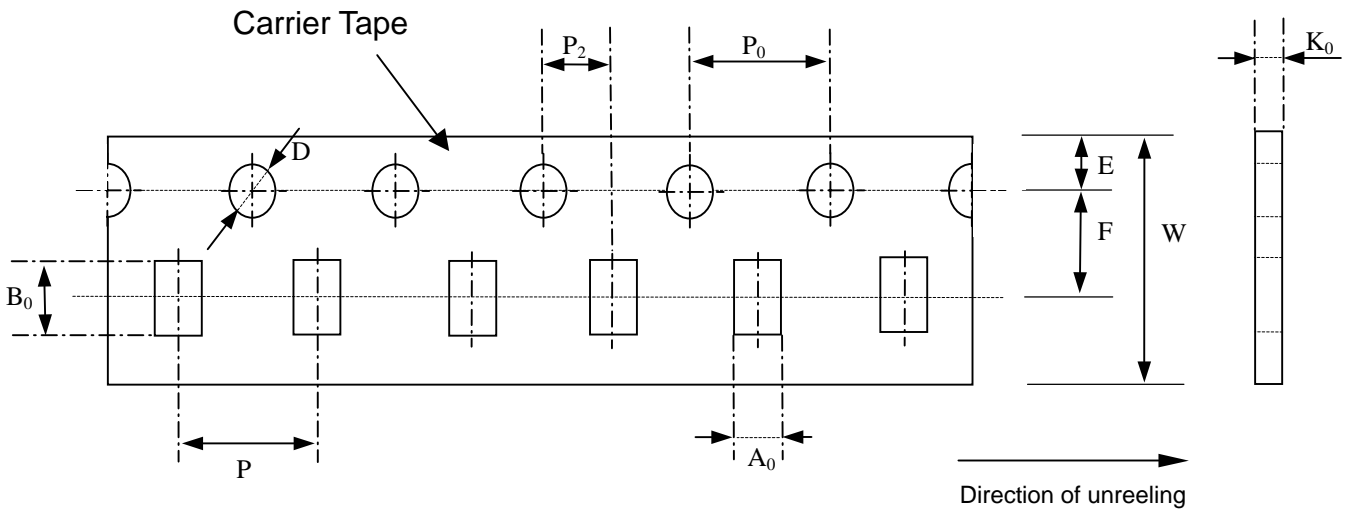

Symbol	A_0 ± 0.05	B_0 ± 0.05	K_0 ± 0.05	D $+0.10$ -0.05	P ± 0.10	P_2 ± 0.10	P_0 ± 0.10	W ± 0.10	E ± 0.10	F ± 0.05
0402	0.62	1.12	0.60	1.55	2.00	2.00	4.00	8.00	1.75	3.50
0603	1.10	1.90	0.95	1.56	4.00	2.00	4.00	8.00	1.75	3.50



HYLINK Technology CO.,LTD

SMD Transient Voltage Suppressors

7.Reel Dimension

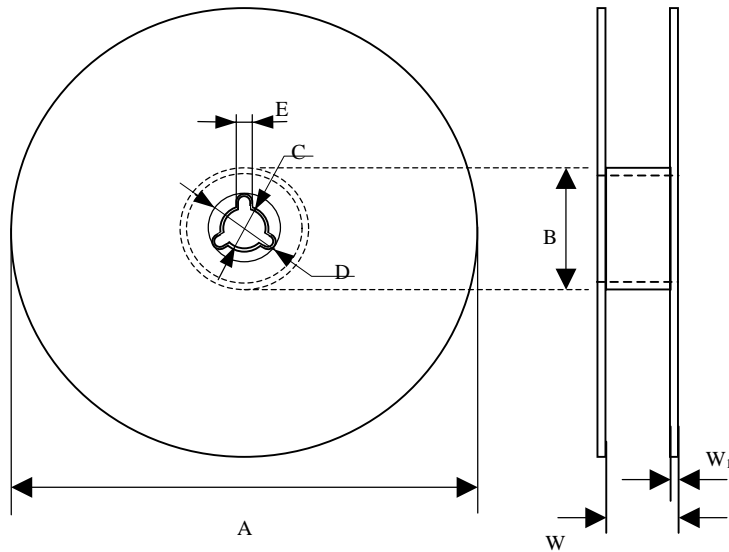

Symbol	A	B	C	D	E	W	W ₁
0402	178.0±1.0	60.0±0.5	13.0±0.2	21.0±0.2	2.0±0.5	9.0±0.50	1.5±0.15
0603	178.0±1.0	60.0±0.5	13.0±0.2	21.0±0.2	2.0±0.5	9.0±0.50	1.5±0.15
0805	178.0±1.0	60.0±0.5	13.0±0.2	21.0±0.2	2.0±0.5	9.0±0.50	1.5±0.15
1206	178.0±1.0	60.0±0.5	13.0±0.2	21.0±0.2	2.0±0.5	9.0±0.50	1.5±0.15
1210	178.0±1.0	60.0±0.5	13.0±0.2	21.0±0.2	2.0±0.5	9.0±0.50	1.5±0.15
1812	178.0±1.0	60.0±0.5	13.5±0.1	21.0±0.2	2.0±0.5	13.6±0.2	1.5±0.15
2220	178.0±1.0	60.0±0.5	13.5±0.1	21.0±0.2	2.0±0.5	13.6±0.2	1.5±0.15

8. Label and marking Unit mm

8.1 The paper label shall be plastered on the obvious side of the reel, and the information show as right side

HYLINK TECHNOLOGY CORP. LTD.

HL P/N:
 CUS. P/N:
 W/V:
 T/V:
 LOT NO:
 WEEK CODE: *****
 Q`TY: *****

Type	0402	0603	0805	1206	1210	1812	2220
Pcs/reel	10,000	4,000	3,000	3,000	2,000	1,000	1,000
Pcs/kg	850,000	168,000	66,000	31,500	18,500	7,600	4,200