

# Anti-Corrosive Thin Film Precision Chip Resistor—PR Series



## Features

- Special Passivated NiCr Film for Anti-Acid and Anti-Damp
- Very Tight Tolerance from  $\pm 0.1\%$
- Extremely Low TCR from  $\pm 25$  PPM/ $^{\circ}\text{C}$
- Wide R-Value Range

## Construction

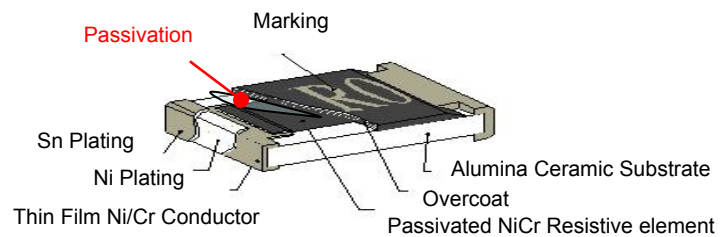

## Applications

- Automotive
- High-end Computer
- Industrial Equipment
- Automatic Equipment Controller
- Medical Equipment
- Telecommunication Device
- High-end Multimedia Electronics

Derating Curve

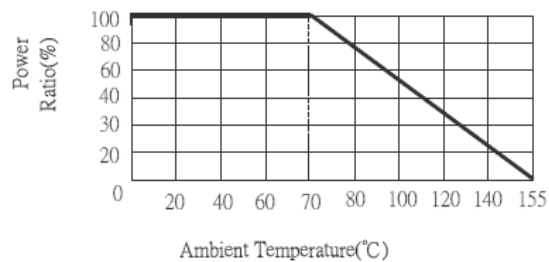

## Part Numbering

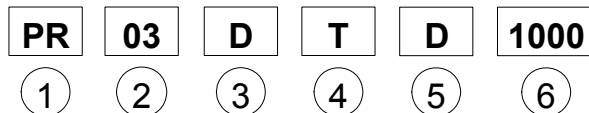

### ① Product Type

Product Type	
PR	Anti-Corrosive Thin film Precision Chip Resistor

### ② Dimensions (L×W)

Codes	Dimensions (L×W)	EIA
PR02	1.00×0.50mm	0402
PR03	1.60×0.80mm	0603
PR05	2.00×1.25mm	0805
PR06	3.00×1.50mm	1206
PR10	4.90×2.40mm	2010
PR12	6.30×3.10mm	2512

### ③ Resistance Tolerance

Codes	Resistance Tolerance
B	$\pm 0.10\%$
C	$\pm 0.25\%$
D	$\pm 0.50\%$

### ④ Packaging

Codes	Type
T	Taping Reel
B	Bulk

### ⑤ TCR

Codes	Type
C	$\pm 25$ PPM/ $^{\circ}\text{C}$
D	$\pm 50$ PPM/ $^{\circ}\text{C}$

### ⑥ Resistance

Codes	Type
1000	100 $\Omega$
2201	2200 $\Omega$
1002	10000 $\Omega$
4992	49900 $\Omega$
1003	100000 $\Omega$

## Dimensions

Unit: mm

Codes	L	W	T	D1	D2
PR02	1.00±0.05	0.50±0.05	0.30±0.05	0.20±0.10	0.20±0.10
PR03	1.55±0.10	0.80±0.10	0.45±0.10	0.30±0.20	0.30±0.20
PR05	2.00±0.15	1.25±0.15	0.55±0.10	0.30±0.20	0.40±0.25
PR06	3.05±0.15	1.55±0.15	0.55±0.10	0.42±0.20	0.35±0.25
PR10	4.90±0.15	2.40±0.15	0.55±0.10	0.60±0.30	0.50±0.25
PR12	6.30±0.15	3.10±0.15	0.55±0.10	0.60±0.30	0.50±0.25

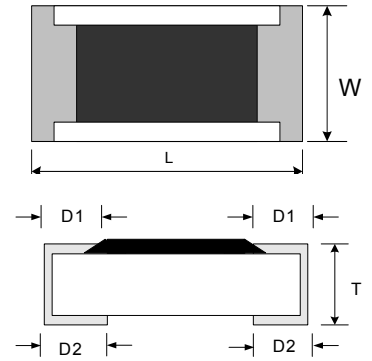

## Standard Electrical Specifications

Item Type	Power Rating at 70°C	Operating Temp. Range	Max Operating Voltage	Max Overloading Voltage	Resistance Tolerance	Resistance Range	TCR (PPM/°C)
PR02 (0402)	1/16W	-55 ~ +155°C	25V	50V	±0.10% ±0.25% ±0.50%	25Ω~25KΩ	±25 ±50
PR03 (0603)	1/16W	-55 ~ +155°C	50V	100V	±0.10% ±0.25% ±0.50%	25Ω~200KΩ	±25 ±50
PR05 (0805)	1/10W	-55 ~ +155°C	100V	200V	±0.10% ±0.25% ±0.50%	25Ω~400KΩ	±25 ±50
PR06 (1206)	1/8W	-55 ~ +155°C	150V	300V	±0.10% ±0.25% ±0.50%	25Ω~500KΩ	±25 ±50
PR10(2010)	1/4W	-55 ~ +155°C	150V	300V	±0.10% ±0.25% ±0.50%	25Ω~600KΩ	±25 ±50
PR12 (2512)	1/2W	-55 ~ +155°C	150V	300V	±0.10% ±0.25% ±0.50%	25Ω~600KΩ	±25 ±50

## Packaging

### Packaging Quantity & Reel Specifications

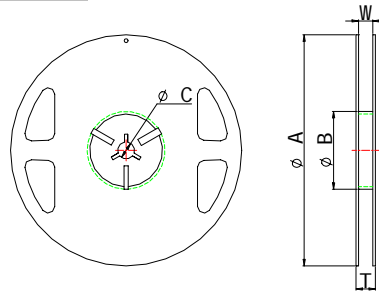

Unit: mm

Codes	ΦA	ΦB	ΦC	W	T	Paper Tape (EA)	Emboss Plastic Tape (EA)
PR02	178±1	60.0+0.5	13.0±0.20	9.00±0.50	12.0±0.15	10,000	-
PR03	178±1	60.0+0.5	13.0±0.20	9.00±0.50	12.0±0.15	5,000	-
PR05	178±1	60.0+0.5	13.0±0.20	9.00±0.50	12.0±0.15	5,000	-
PR06	178±1	60.0+0.5	13.0±0.20	9.00±0.50	12.0±0.15	5,000	-
PR10	178±1	60.2±0.5	13.0±1.00	13.2±1.50	16.0±0.20	-	4,000
PR12	178±1	60.2±0.5	13.0±0.50	13.2±1.50	16.0±0.20	-	4,000

## Packaging

### Paper Tape Specifications

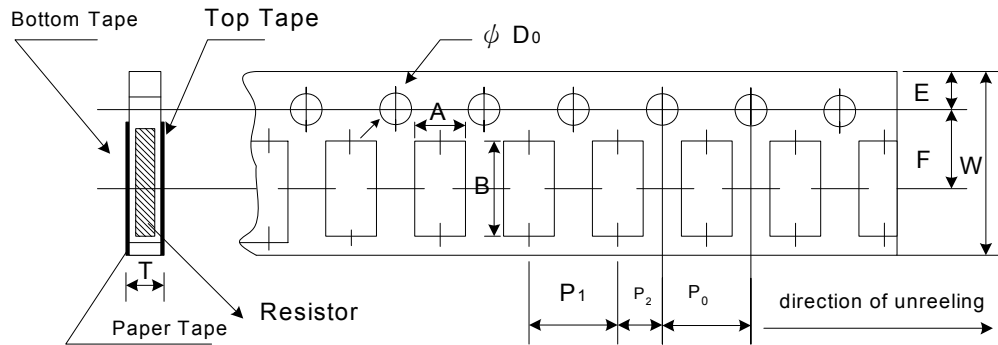

Unit: mm

Codes	A	B	W	E	F	P <sub>0</sub>	P <sub>1</sub>	P <sub>2</sub>	ΦD <sub>0</sub>	T
PR02	0.70±0.05	1.16±0.05	8.00±0.10	1.75±0.05	3.5±0.05	4.00±0.10	2.00±0.05	2.00±0.05	1.55±0.05	0.40±0.03
PR03	1.10±0.05	1.90±0.05	8.00±0.10	1.75±0.05	3.5±0.05	4.00±0.10	4.00±0.10	2.00±0.05	1.55±0.05	0.60±0.03
PR05	1.60±0.05	2.37±0.05	8.00±0.10	1.75±0.05	3.5±0.05	4.00±0.10	4.00±0.10	2.00±0.05	1.55±0.05	0.75±0.05
PR06	2.00±0.05	3.55±0.05	8.00±0.10	1.75±0.05	3.5±0.05	4.00±0.10	4.00±0.10	2.00±0.05	1.55±0.05	0.75±0.05

### Emboss Plastic Tape Specifications

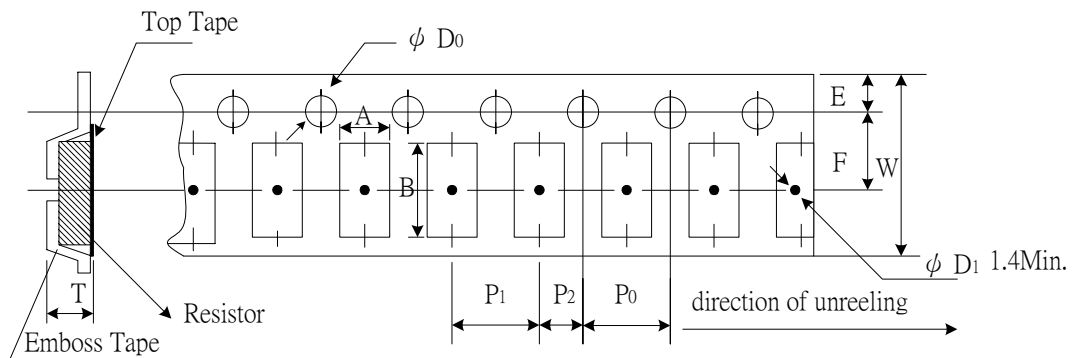

Unit: mm

Codes	A	B	W	E	F	P <sub>0</sub>	P <sub>1</sub>	P <sub>2</sub>	ΦD <sub>0</sub>	T
PR10	2.85±0.10	5.45±0.10	12.0±0.10	1.75±0.10	5.5±0.05	4.00±0.05	4.00±0.10	2.00±0.05	1.50±0.10	1.00±0.20
PR12	3.40±0.10	6.65±0.10	12.0±0.10	1.75±0.10	5.5±0.05	4.00±0.05	4.00±0.10	2.00±0.05	1.50±0.10	1.00±0.20

### Recommend Land Pattern

Unit : mm

Codes	A	B	C
PR12	4.90	1.60	3.10±0.2
PR10	3.60	1.40	2.50±0.2
PR06	2.00	1.15	1.70±0.2
PR05	1.00	1.00	1.35±0.2
PR03	0.80	1.00	0.90±0.2
PR02	0.50	0.50	0.60±0.2

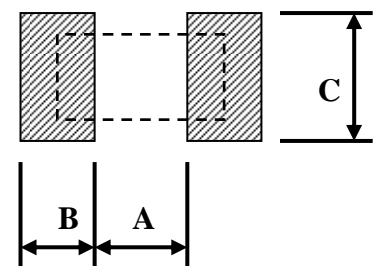

## Environmental Characteristics

Test Item	Specification		Test Method
	Size 0603 / 0805 1206 / 2010 2512	Size 0402	
Short Time Overload	$\leq \pm 0.02\%$	$\leq \pm 0.1\%$	RCWV*2.5 or Max Overloading Voltage , 2 seconds
Thermal Shock	$\leq \pm 0.02\%$	$\leq \pm 0.1\%$	<b>MIL-STD-202F Method 107G</b> -55°C~125°C,100 cycles
Load Life	$\leq \pm 0.05\%$	$\leq \pm 0.25\%$	<b>MIL-STD-202F Method 108A</b> RCWV , 70°C , 1.5 hours ON , 0.5 hours OFF, total 1000~1048 hours
Humidity ( Steady State )	$\leq \pm 0.05\%$	$\leq \pm 0.5\%$	<b>MIL-STD-202F Method 103B</b> 40°C , 90~95%RH,RCWV 1.5 hours ON,0.5 hours OFF, total 1000~1048 hours
Resistance to Dry Heat	$\leq \pm 0.05\%$	$\leq \pm 0.5\%$	<b>JIS-C-5202-7.2</b> 1000 hours @ +125°C without load
Resistance to Soldering Heat	$\leq \pm 0.02\%$	$\leq \pm 0.1\%$	<b>MIL-STD-202F Method 210E</b> 260±5°C , 10±1 seconds

\* Storage Temperature :25±3°C; Humidity <80%RH