



ISA-PLAN® - SMD Präzisionswiderstände / SMD precision resistors

TECHNISCHE DATEN / TECHNICAL DATA		
Widerstandswerte (mOhm)	Resistance values (mOhm)	5,10,20,22,25,33,47,50,100,200
Toleranz	Tolerance	0.5 %, 1 %, 2 %, 5 %
Temperaturkoeffizient(MANGANIN®)	Temperature coefficient (tcr)	< 30 ppm/K (20 °C to 60 °C)
Temperaturbereich	Applicable temperature range	-55 °C to +170 °C
Belastbarkeit	Load capacity	3 W
Innerer Wärmewiderstand (R_{thi})	Internal heat resistance (R_{thi})	< 10 K/W
Isolationsspannung	Dielectric withstanding voltage	100 VAC
Induktivität	Inductance	< 3 nH
Stabilität (Nennlast) Abweichung T_K = Kontaktstellentemperatur Stability (nominal load) deviation T_K = Terminal temperature		< 0.5 % nach/after 2000 h (T_K = 105 °C) < 1.0 % nach/after 2000 h (T_K = 140 °C)

MERKMALE / FEATURES

- 3 Watt Dauerleistung
- 3 Watt permanent power
- Dauerströme bis 24 A (5 mOhm)
- Constant current up to 24 Amps (5 mOhm)
- Vier-Leiter Messwiderstand
- Resistor with Kelvin connection
- Vergoldete Bondflächen (0,1µm)
- Au-plated bond pads (0,1µm)
- Bauteilrückseite vergoldet (0,1 µm typ.)
- Reverse side covered with gold flash (0.1 µm typ.)
- Geeignet für Löttemperaturen bis 280 °C / 30 sek
oder 250 °C / 5 min (Kupferseite auf Substrat)
- Max. solder temperature up to 280 °C / 30 sec
or 250 °C / 5 min
- Bauteilmontage: Reflow löten und Kleben auf
Substrat
- Mounting: reflow soldering and epoxy attachment
on substrate

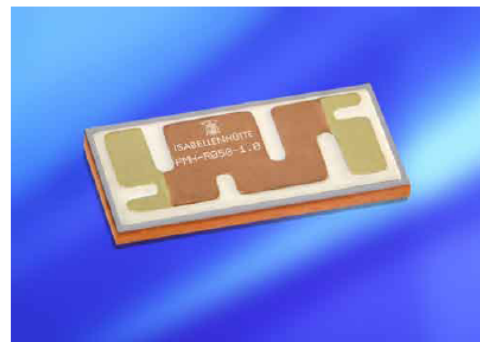

Bauform/Size 2512

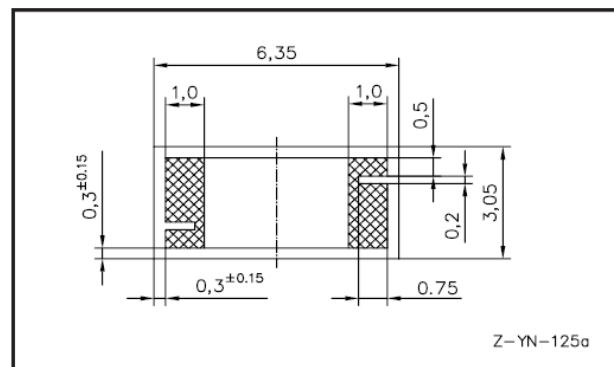

Layout Typ A / Layout type A

APPLIKATIONEN / APPLICATION

- Messwiderstand für Leistungshybride
- Current sensor for power hybrid applications
- Frequenzumrichter
- Frequency converters
- Leistungsmodule
- Power modules

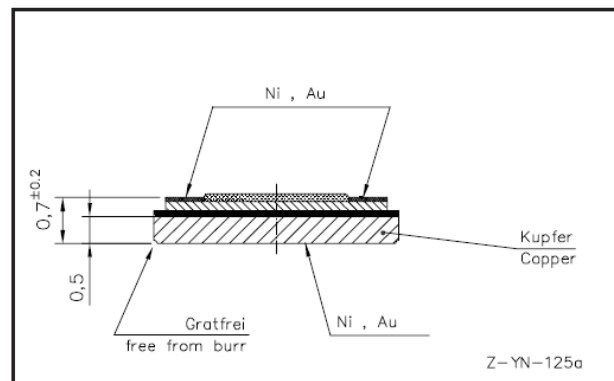

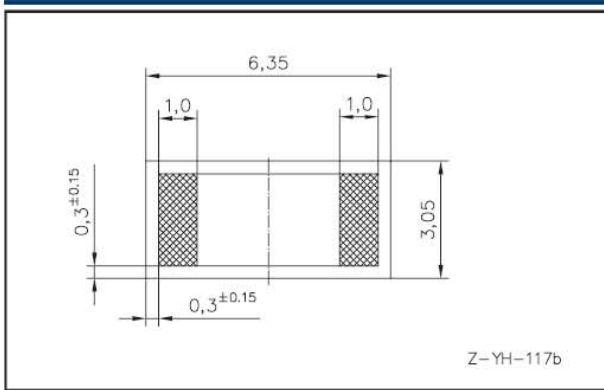

Layout Typ B / Layout type B

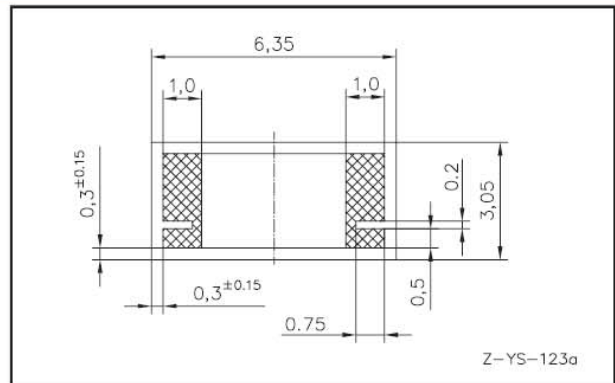

Layout Typ C / Layout type C

TK, Lastminderung und Langzeitstabilität / TCR, power derating and long term stability

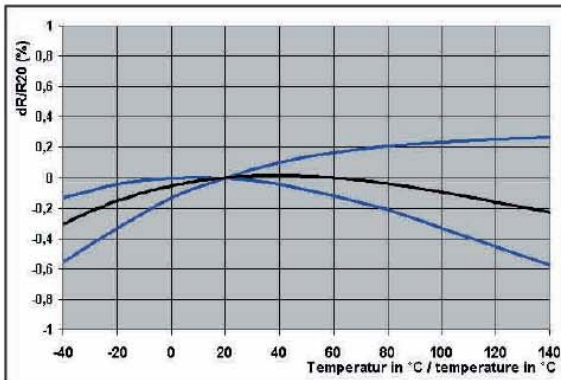

Temperaturabhängigkeit des elektrischen Widerstandes von MANGANIN®-Widerständen
Temperature dependence of the electrical resistance of MANGANIN®-resistors

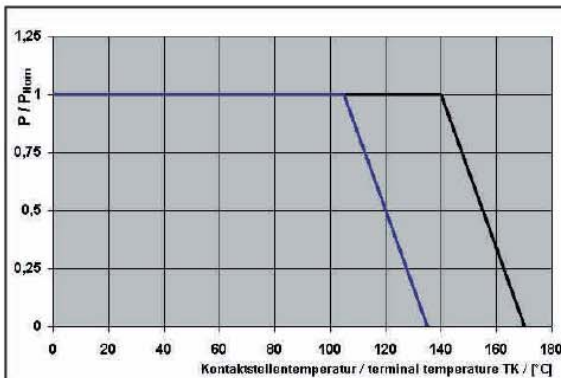

Lastminderungskurve
Power derating curve

- Stabilität/Stability < 1.0 %
- Verbesserte Stabilität/Improved stability < 0.5 %

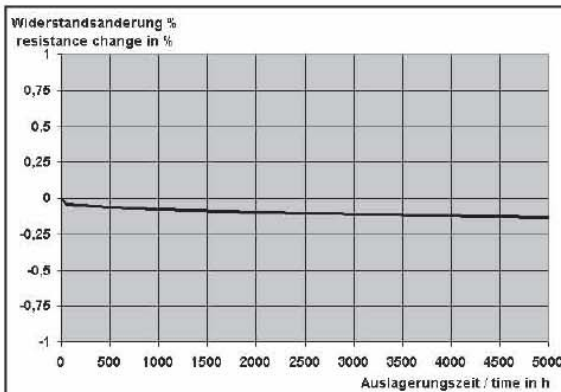

Langzeitstabilität von MANGANIN®-Widerständen bei 140 °C
Long term stability of MANGANIN®-resistors at 140 °C



Vorschlag für Bondverbindungen / Proposal for bond-connection

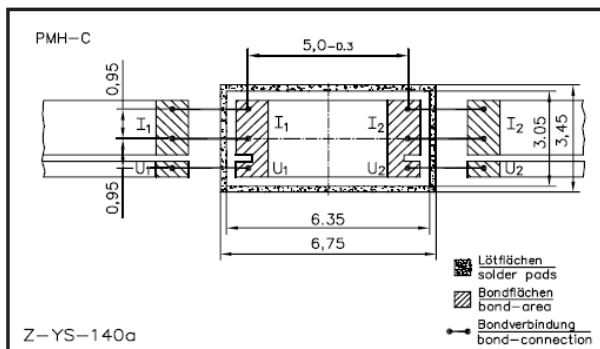
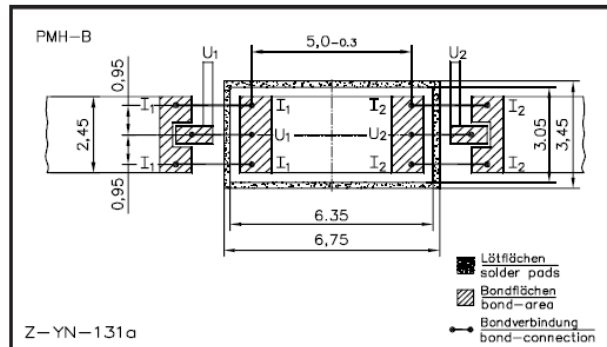
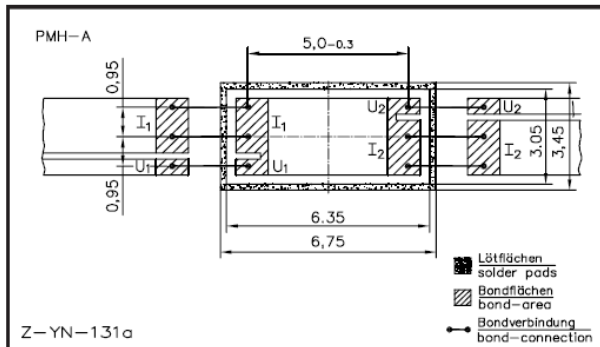

Layout B: Bei Bei Mäanderform des Widerstandsmaterials kann die Anordnung der Bonddrähte gemäß Layout A sinnvoller sein / For meander-structure of resistance material the bond proposal acc. layout A could be better.

Lötprofil Vorschlag / Recommended solder profile			
Reflow-, IR-löten			
Reflow, infrared soldering			
Temperatur	260 °C	255 °C	217 °C
Zeit (s)	peak	40	90
RoHS 2002/95/EG konform seit Produktstart			
Ausführliche Informationen erhalten Sie auf unserer Homepage: www.isabellenhuette.de			
RoHS 2002/95/EC compliance since product launch.			
For more information please visit our website: www.isabellenhuette.de			

GURTINFORMATIONEN TAPE & REEL INFORMATION	
Norm / Specification	DIN EN 60286-3
Gurtbreite / Tape width	12 mm
Anzahl Bauteile/Parts per reel	5000

BESTELLBEZEICHNUNG / ORDERING CODE			
PMH-A-R005-1.0			
Typ	Layout	Widerstandswert	Toleranz
Type	Layout	Resistance value	Tolerance
PMH	A/B/C	5 mOhm	1.0 %

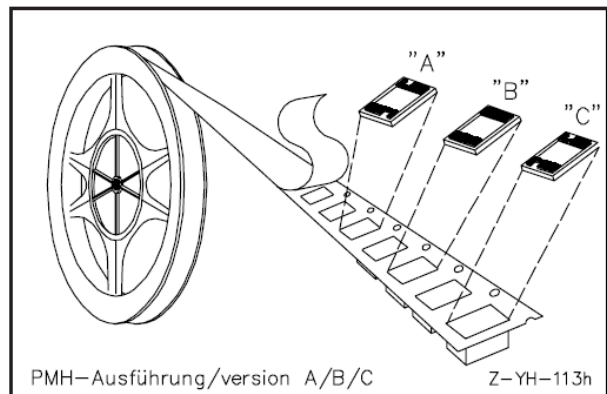

Gewährleistung
Alle Angaben über Eignung, Verarbeitung und Anwendung unserer Produkte, technische Beratung und sonstige Angaben erfolgen nach bestem Willen, befreien den Käufer jedoch nicht von eigenen Prüfungen und Versuchen.

Warranty
All information regarding the suitable, workability and applicability of our products, all technical advice and other information are provided to the best of our knowledge and belief, but shall not discharge the buyer from his own examinations and tests.



Grenzkurve für maximale Pulsenergie bzw. Pulsleistung für Dauerbetrieb
Maximum puls energy resp. pulse power for continous operation

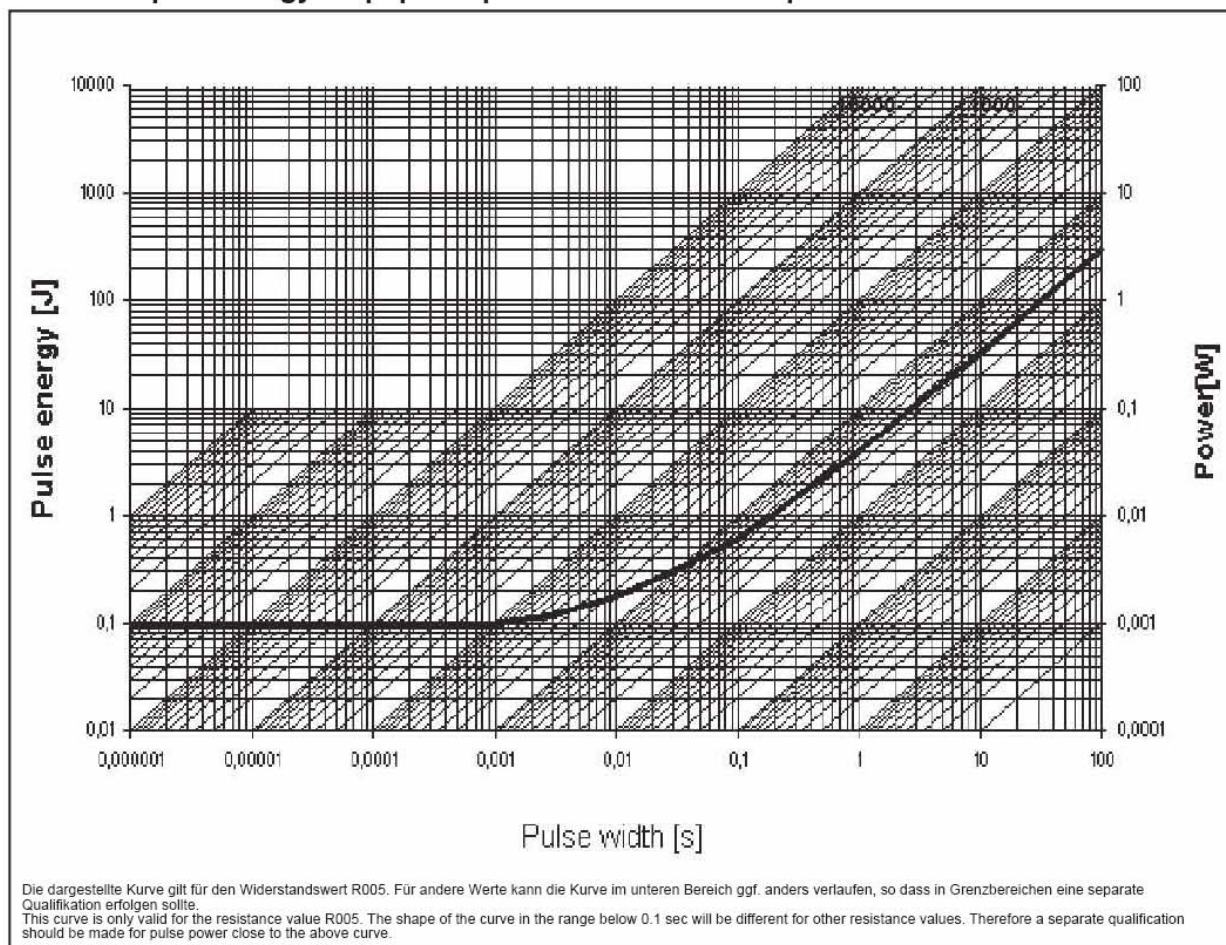

MIL. - STANDARD		
Parameters	Test Conditions	Specification
Maximum Temperature for full power operation	140 °C	140 °C
Working Temperature	-55 to 170 °C	-55 to 170 °C
Thermal Shock	MIL-STD-202 method 107E-B1	0.1 %
Overload	MIL-R-26E (5 times rated power, 5 sec)	0.2 %
Solderability	MIL-STD-202 method 208	> 95 % coverage
Resistance to Solvents	MIL-STD-202 method 215A, 2.1a, 2.1d	no damage
Low Temperature Storage and Operation	MIL-STD-26E	0.1 %
Resistance to Soldering Heat	MIL-STD-202 method 210B	0.1 %
Moisture Resistance	MIL-STD-202 method 106	0.1 %
Shock	MIL-STD-202 method 213B-A	0.2 %
Vibration, High Frequency	MIL-STD-202 method 204D-B	0.2 %
Life	MIL-STD-26E	0.2 %
Storage Life at Elevated Temperature	MIL-STD-202 method 108A-F	0.3 %
High Temperature Exposure	140 °C, 2000 h	0.2%
Current Noise	MIL-STD-202 method 308	0.01 %
Voltage Coefficient (%/V)	MIL-STD-202 method 309	linearity error less than 120dB
Resistance Temperature Characteristic	MIL-STD-202 method 304 (20-60°C)	<30 ppm/K
Thermal EMF	0 - 100 °C	2 µV/ °C max.
Frequency Characteristic	inductivity	< 3 nH