

Thin Film Precision Chip Resistor—AR Series



Features

- Thin Film Passivated NiCr Resistor
- Very Tight Tolerance from $\pm 0.01\%$ ~ 1%
- Extremely Low TCR from ± 5 ~ ± 50 PPM/ $^{\circ}\text{C}$
- Wide R-Value Range

Construction

Applications

- Medical Equipment
- Testing / Measurement Equipment
- Consumer Product
- Printer Equipment
- Automatic Equipment Controller
- Converters
- Communication Device, Cell phone, GPS, PDA

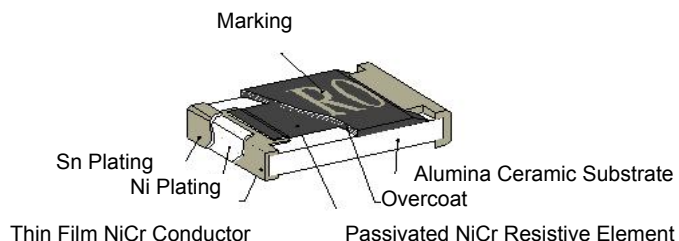

Derating Curve

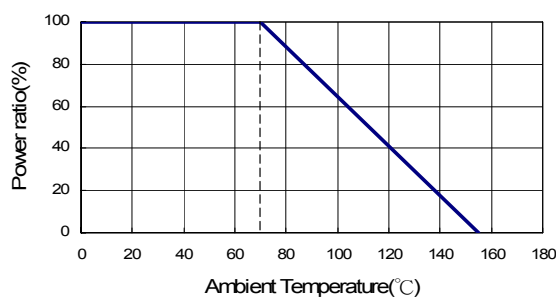

Part Numbering

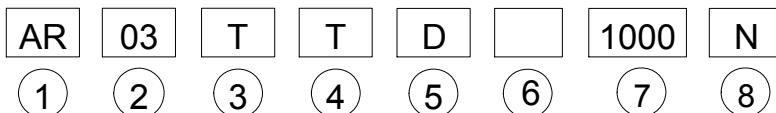

① Product Type

Product Type	
AR	Thin Film Precision Chip Resistor

② Dimensions (LxW)

Codes	Dimensions (LxW)	EIA
AR02	1.00×0.50mm	0402
AR03	1.60×0.80mm	0603
AR05	2.00×1.25mm	0805
AR06	3.00×1.50mm	1206
AR10	4.90×2.40mm	2010
AR12	6.30×3.10mm	2512

③ Resistance Tolerance

Codes	Resistance Tolerance
T	$\pm 0.01\%$
A	$\pm 0.05\%$
B	$\pm 0.10\%$
C	$\pm 0.25\%$
D	$\pm 0.50\%$
F	$\pm 1.00\%$

④ Packaging

Codes	Type
T	Taping Reel
B	Bulk

⑤ TCR

Codes	Type
S	± 5 PPM/ $^{\circ}\text{C}$
B	± 10 PPM/ $^{\circ}\text{C}$
N	± 15 PPM/ $^{\circ}\text{C}$
C	± 25 PPM/ $^{\circ}\text{C}$
D	± 50 PPM/ $^{\circ}\text{C}$

⑥ Higher Power Rating

Codes	Power Rating
	Standard / Special
U	1/2W
V	1/4W
W	1/8W
X	1/10W
T	1W

⑦ Resistance

Codes	Type
0010	1 Ω
4R70	4.7 Ω
1000	100 Ω
2201	2200 Ω
1002	10000 Ω
4992	49900 Ω
1003	100000 Ω

⑧ Marking

Codes	Type
	Standard Marking for E96 / E24
N	No Marking

Dimensions

Unit: mm

Codes	L	W	T	D1	D2
AR02	1.00±0.05	0.50±0.05	0.30±0.05	0.20±0.10	0.20±0.10
AR03	1.55±0.10	0.80±0.10	0.45±0.10	0.30±0.20	0.30±0.20
AR05	2.00±0.15	1.25±0.15	0.55±0.10	0.30±0.20	0.40±0.25
AR06	3.05±0.15	1.55±0.15	0.55±0.10	0.42±0.20	0.35±0.25
AR10	4.90±0.15	2.40±0.15	0.55±0.10	0.60±0.30	0.50±0.25
AR12	6.30±0.15	3.10±0.15	0.55±0.10	0.60±0.30	0.50±0.25

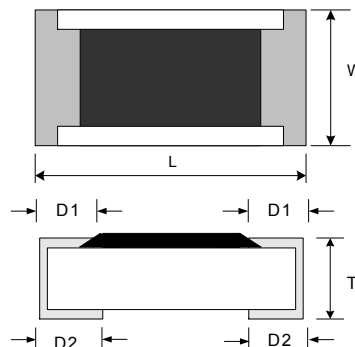

Standard Electrical Specifications

Item Type	Power Rating at 70°C	Operating Temp. Range	Max Operating Voltage	Max Overloading Voltage	Resistance Tolerance	Resistance Range	TCR (PPM/°C)
AR02 (0402)	1/16W	-55 ~ +155°C	25V	50V	±0.10% ±0.25% ±0.50%	10Ω~205KΩ	±25 ±50
AR03 (0603)	1/16W	-55 ~ +155°C	50V	100V	±0.05%	4.7Ω~150KΩ	±25 ±50
					±0.10%	4.7Ω~1MΩ	
AR05 (0805)	1/10W	-55 ~ +155°C	100V	200V	±0.25% ±0.50%	2Ω~1MΩ	±25 ±50
					±0.05%	4.7Ω~500KΩ	
					±0.10%	4.7Ω~2MΩ	
AR06 (1206)	1/8W	-55 ~ +155°C	150V	300V	±0.25% ±0.50%	1Ω~2MΩ	±25 ±50
					±0.05%	4.7Ω~1MΩ	
					±0.10%	4.7Ω~2.5MΩ	
AR10 (2010)	1/4W	-55 ~ +155°C	150V	300V	±0.05%	4.7Ω~1MΩ	±25 ±50
					±0.10%	4.7Ω~3MΩ	
AR12 (2512)	1/2W	-55 ~ +155°C	150V	300V	±0.25% ±0.50%	1Ω~3MΩ	±25 ±50

Special Electrical Specifications

Item Type	Power Rating at 70°C	Operating Temp. Range	Max Operating Voltage	Max Overloading Voltage	Resistance Tolerance	Resistance Range	TCR (PPM/°C)
AR02 (0402)	1/16W	-55 ~ +155°C	25V	50V	±0.01%	49.9Ω~3KΩ	±5
					±0.05% ±0.10%	49.9Ω~12KΩ	±10 ±15
AR03 (0603)	1/16W	-55 ~ +155°C	50V	100V	±0.01%	25Ω~15KΩ	±5
					±0.05% ±0.10%	25Ω~100KΩ	±10 ±15
					±0.10%	4.7Ω~332KΩ	±10
AR05 (0805)	1/10W	-55 ~ +155°C	100V	200V	±0.01%	25Ω~30KΩ	±5
					±0.05% ±0.10%	25Ω~200KΩ	±10 ±15
					±0.05% ±0.10%	4.7Ω~500KΩ	±10
AR06 (1206)	1/8W	-55 ~ +155°C	150V	300V	±0.01%	25Ω~50KΩ	±5
					±0.05% ±0.10%	25Ω~500KΩ	±10 ±15
					±0.10%	4.7Ω~1MΩ	±10
AR10 (2010)	1/4W	-55 ~ +155°C	150V	300V	±0.01%	25Ω~100KΩ	±5
					±0.05% ±0.10%	25Ω~500KΩ	±10 ±15
					±0.10%	4.7Ω~1MΩ	±10
AR12 (2512)	1/2W	-55 ~ +155°C	150V	300V	±0.01%	25Ω~100KΩ	±5
					±0.05% ±0.10%	25Ω~500KΩ	±10 ±15
					±0.10%	4.7Ω~1MΩ	±10

Higher Power Rating Electrical Specifications

Item Type	Power Rating at 70°C	Operating Temp. Range	Max Operating Voltage	Max Overloading Voltage	Resistance Tolerance	Resistance Range	TCR (PPM/°C)
AR03 (0603)	1/10W	-55 ~ +155°C	50V	100V	±0.10% ±0.25% ±0.50%	10Ω~332KΩ	±25 ±50
AR05 (0805)	1/8W	-55 ~ +155°C	150V	300V	±0.10% ±0.25% ±0.50%	4.7Ω~1MΩ	±25 ±50
AR06 (1206)	1/4W	-55 ~ +155°C	200V	400V	±0.10% ±0.25% ±0.50%	4.7Ω~1MΩ	±25 ±50

Packaging

Packaging Quantity & Reel Specifications

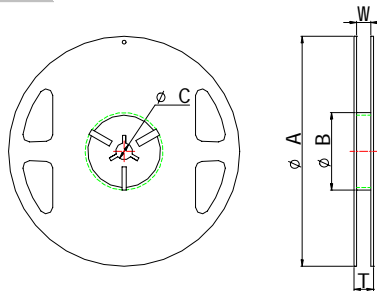

Unit: mm

Codes	ΦA	ΦB	ΦC	W	T	Paper Tape (EA)	Emboss Plastic Tape (EA)
AR02	178±1	60.0±0.5	13.0±0.20	9.00±0.50	12.0±0.15	10,000	-
AR03	178±1	60.0±0.5	13.0±0.20	9.00±0.50	12.0±0.15	5,000	-
AR05	178±1	60.0±0.5	13.0±0.20	9.00±0.50	12.0±0.15	5,000	-
AR06	178±1	60.0±0.5	13.0±0.20	9.00±0.50	12.0±0.15	5,000	-
AR10	178±1	60.2±0.5	13.0±1.00	13.2±1.50	16.0±0.20	-	4,000
AR12	178±1	60.2±0.5	13.0±0.50	13.2±1.50	16.0±0.20	-	4,000

Packaging

Paper Tape Specifications

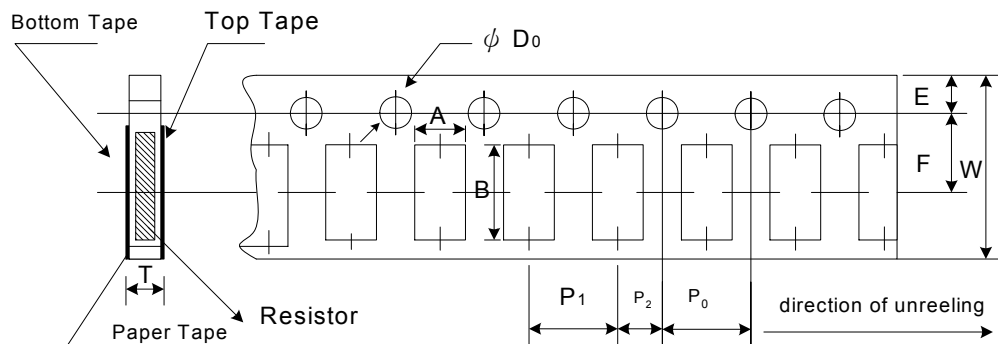

Unit: mm

Codes	A	B	W	E	F	P0	P1	P2	ΦD0	T
AR02	0.70±0.05	1.16±0.05	8.00±0.10	1.75±0.05	3.5±0.05	4.00±0.10	2.00±0.05	2.00±0.05	1.55±0.05	0.40±0.03
AR03	1.10±0.05	1.90±0.05	8.00±0.10	1.75±0.05	3.5±0.05	4.00±0.10	4.00±0.10	2.00±0.05	1.55±0.05	0.60±0.03
AR05	1.60±0.05	2.37±0.05	8.00±0.10	1.75±0.05	3.5±0.05	4.00±0.10	4.00±0.10	2.00±0.05	1.55±0.05	0.75±0.05
AR06	2.00±0.05	3.55±0.05	8.00±0.10	1.75±0.05	3.5±0.05	4.00±0.10	4.00±0.10	2.00±0.05	1.55±0.05	0.75±0.05

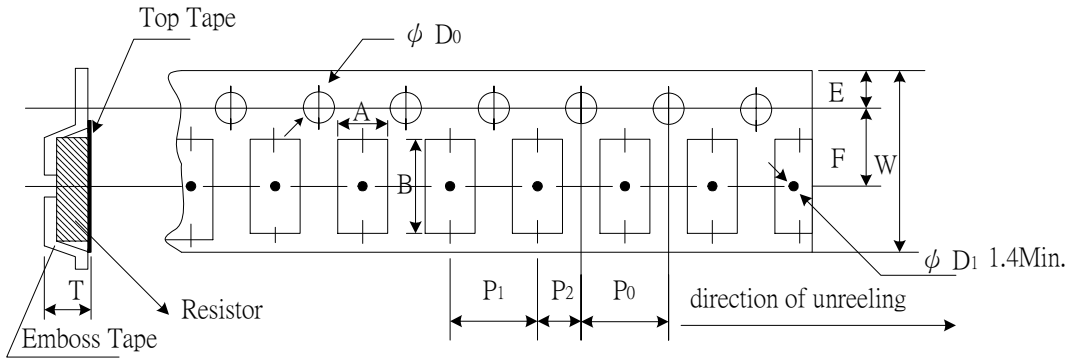
Emboss Plastic Tape Specifications

Unit: mm

Codes	A	B	W	E	F	P ₀	P ₁	P ₂	ΦD ₀	T
AR10	2.85±0.10	5.45±0.10	12.0±0.10	1.75±0.10	5.5±0.05	4.00±0.05	4.00±0.10	2.00±0.05	1.50±0.10	1.00±0.20
AR12	3.40±0.10	6.65±0.10	12.0±0.10	1.75±0.10	5.5±0.05	4.00±0.05	4.00±0.10	2.00±0.05	1.50±0.10	1.00±0.20

Recommend Land Pattern

Unit : mm

Codes	A	B	C
AR12	4.90	1.60	3.10±0.2
AR10	3.60	1.40	2.50±0.2
AR06	2.00	1.15	1.70±0.2
AR05	1.00	1.00	1.35±0.2
AR03	0.80	1.00	0.90±0.2
AR02	0.50	0.50	0.60±0.2

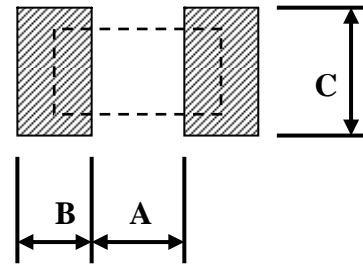



Environmental Characteristics

Test Item	Specification		Test Method
	Tol. ≤0.05%	Tol.>0.05%	
Temperature Coefficient of Resistance	As Spec		MIL-STD-202F Method 304 +25/-55/+25/+125/+25°C
Short Time Overload	ΔR±0.05%	ΔR±0.5%	JIS-C-5202-5.5 RCWV*2.5 or Max Overloading Voltage · 5 seconds
	ΔR±0.5% for high power rating		
Dielectric Withstand Voltage	By type		MIL-STD-202F Method 301 Apply Max Overload Voltage for 1 minute
Insulation Resistance	>1000MΩ		MIL-STD-202F Method 302 Apply 100V _{DC} for 1 minute
Thermal Shock	ΔR±0.05%	ΔR±0.25%	MIL-STD-202F Method 107G -55°C~150°C, 100 cycles
Load Life	ΔR±0.05%	ΔR±0.2%	MIL-STD-202F Method 108A RCWV · 70°C · 1.5 hours ON · 0.5 hours OFF, total 1000~1048 hours
	>7kΩ ΔR±0.5%		
	ΔR±0.5% for high power rating		
Humidity (Steady State)	ΔR±0.05%	ΔR±0.3%	MIL-STD-202F Method 103B 40°C , 90~95%RH,RCWV 1.5 hours ON,0.5 hours OFF, total 1000~1048 hours
	ΔR±0.5% for high power rating		
Resistance to Dry Heat	ΔR±0.05%	ΔR±0.2%	JIS-C-5202-7.2 96 hours @ +155°C without load
Low Temperature Operation	ΔR±0.05%	ΔR±0.2%	JIS-C-5202-7.1 1 hours,-65°C ,followed by 45minutes of RCWV
	ΔR±0.5% for high power rating		
Bending Strength	ΔR±0.05%	ΔR±0.2%	JIS-C-5202-6.1.4 Bending Amplitude 3mm for 10 seconds
Solderability	95%min coverage		MIL-STD-202F Method 208H 245°C±5°C, 2±0.5 (sec)
Resistance to Soldering Heat	ΔR±0.05%	ΔR±0.2%	MIL-STD-202F Method 210E 260±5°C, 10±1 seconds

* Storage Temperature :25±3°C; Humidity <80%RH