

PRODUCT SPECIFICATION

DATE: 12/04/'03

COSMO ELECTRONICS CORPORATION	REED RELAY: CG1A030000	NO. 50R27001	REV. 1
		SHEET 1 OF 2	

1. OUTSIDE DIMENSION : UNIT (mm)

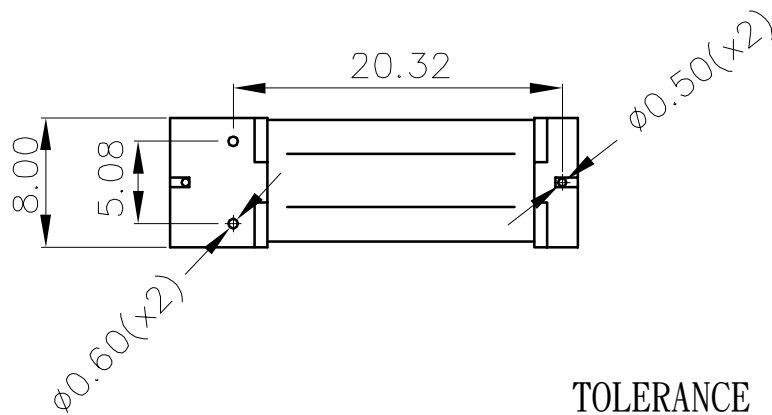
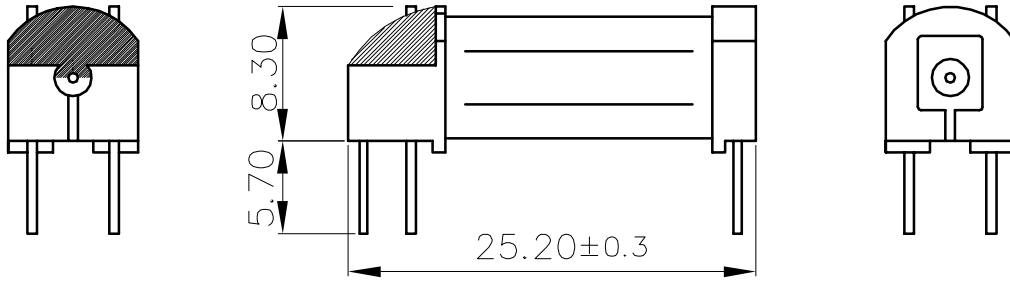

TOLERANCE : ± 0.2mm

2. SCHEMATIC : TOP VIEW

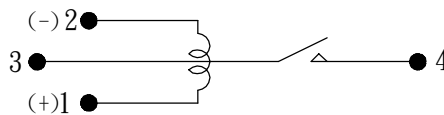

PRODUCT SPECIFICATION

DATE: 12/04/' 03

COSMO ELECTRONICS CORPORATION	REED RELAY: CG1A030000	NO. 50R27001	REV. 1
		SHEET 2 OF 2	

3.0 COIL RATINGS: (AT 20°C)

3.1	Coil resistance	63	Ω	($\pm 10\%$)
3.2	Nominal coil current	3	VDC	
3.3	Maximun Continuous voltage	4.8	VDC	
3.4	Must operate	2.1	VDC	
3.5	Must release	0.3	VDC	
3.6	Rated current	47.6	mA	

4.0 ELECTRONICAL CHARACTERISTICS:

4.1	Contact resistance	150	m Ω	(max)
4.2	Operate time	1.0	ms	(max)
4.3	Bounce time	0.5	ms	(max)
4.4	Release time	0.5	ms	(max)
4.5	Insulation resistance (100 VDC open contact)	10^9	Ω	(min)
	(between coil & contact 500VDC)	10^8	Ω	(min)
4.6	Power	10	VA	(max)
4.7	Switching voltage	100	VDC	(max)
4.8	Switching current	0.5	A	(max)
4.9	Carry current	1.0	A	(max)
4.10	Breakdown voltage (across open contact)	200	VDC	(1sec)
	(between coil & contact)	3000	VDC	(1sec)
4.11	Life expectancy (6V, 10mA)	10^7		
4.12	Temperature Range	-30 to 60°C		
4.13	Humidity Range	-45 to 85% RH.		
4.14	Shock Endurance	100G (Min)		
4.15	Shock Error Operation	13G (Min)		
4.16	Vibration Endurance	10 to 55HZ Double Amplitude 1.5mm		
4.17	Vibration Error Operation	10 to 55HZ Double Amplitude 1.5mm		
4.18	Minimun permissible load	1VDC, 1mA		