

**5A LOW DROPOUT LINEAR REGULATOR****AZ1084****General Description**

The AZ1084 is a series of low dropout positive voltage regulators with a maximum dropout of 1.5V at 5A of load current.

The series features on-chip thermal limiting which provides protection against any combination of overload and ambient temperatures that would create excessive junction temperatures. It also includes a trimmed band-gap reference and a current limiting circuit.

The AZ1084 is available in 1.5V, 1.8V, 2.5V, 2.85V, 3.3V and 5.0V versions. The fixed versions integrate the adjust resistors. It is also available in an adjustable version which can set the output voltage with two external resistors.

The AZ1084 series is available in standard packages of TO-263-2L, TO-263-3L, TO-220 and TO-252.

**Features**

- Low Dropout Voltage: 1.3V Typically at 5A
- Current Limiting and Thermal Protection
- Output Current: 5A
- Current Limit: 6.5A
- Operating Junction Temperature Range: 0 to 125°C
- Line Regulation: 0.015% (Typical)
- Load Regulation: 0.2% (Typical)

**Applications**

- High Efficiency Linear Regulators
- Battery Chargers
- Post Regulation for Switching Supply
- Microprocessor Supply
- Desktop PCs, RISC and Embedded Processors' Supply

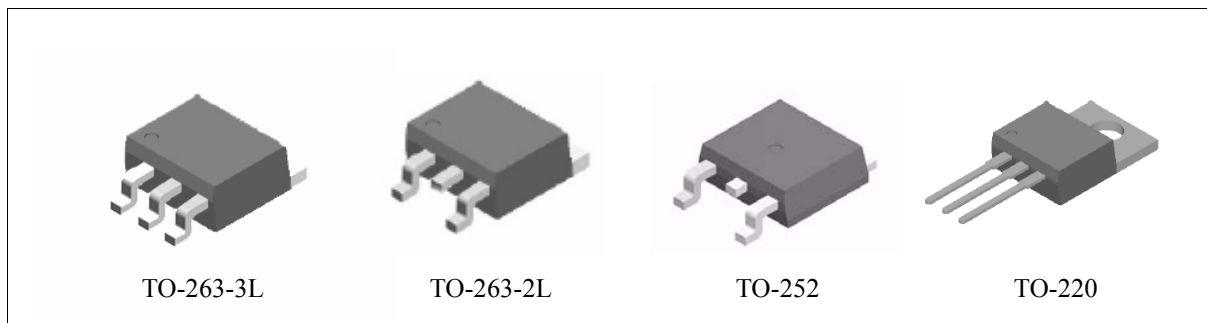

Figure 1. Package Types of AZ1084



**5A LOW DROPOUT LINEAR REGULATOR**

**AZ1084**

**Pin Configuration**

T Package  
(TO-220)

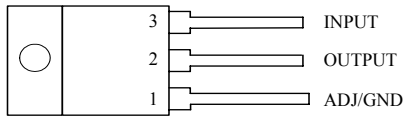

D Package  
(TO-252)

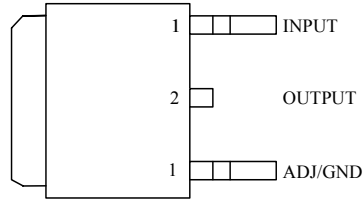

S Package  
(TO-263-3L)

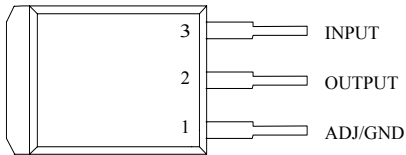

S Package  
(TO-263-2L)

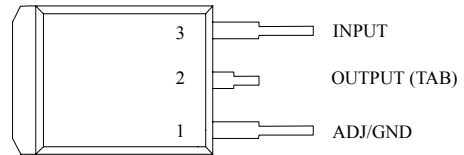

Figure 2. Pin Configuration of AZ1084 (Top View)

**Functional Block Diagram**

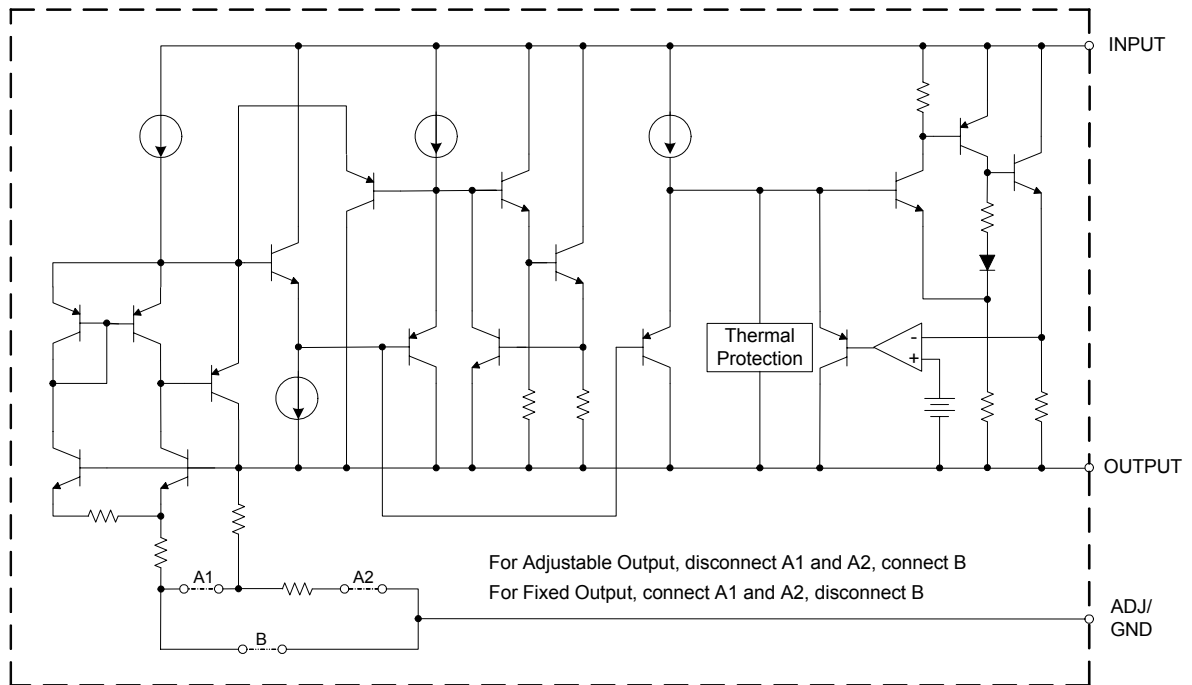

Figure 3. Functional Block Diagram of AZ1084



**5A LOW DROPOUT LINEAR REGULATOR**

**AZ1084**

**Ordering Information**

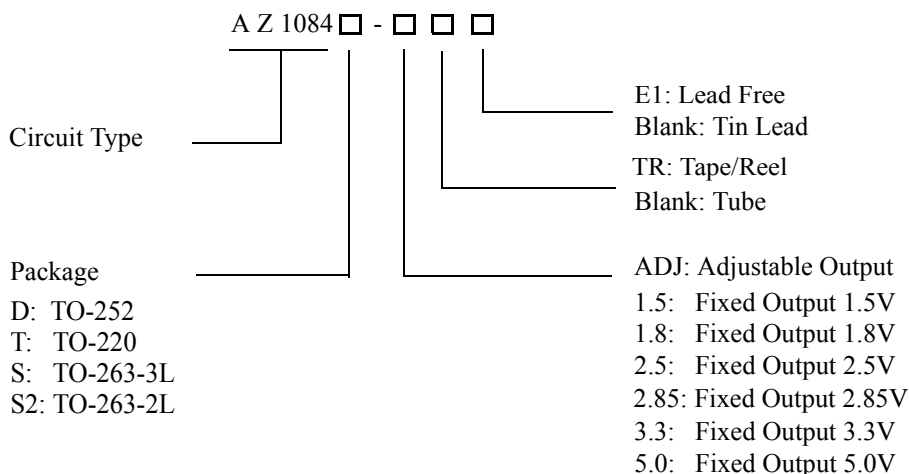

Package	Temperature Range	Part Number		Marking ID		Packing Type
		Tin Lead	Lead Free	Tin Lead	Lead Free	
TO-252	0 to 125°C	AZ1084D-ADJ	AZ1084D-ADJE1	AZ1084D-ADJ	AZ1084D-ADJE1	Tube
		AZ1084D-ADJTR	AZ1084D-ADJTRE1	AZ1084D-ADJ	AZ1084D-ADJE1	Tape/Reel
		AZ1084D-1.5	AZ1084D-1.5E1	AZ1084D-1.5	AZ1084D-1.5E1	Tube
		AZ1084D-1.5TR	AZ1084D-1.5TRE1	AZ1084D-1.5	AZ1084D-1.5E1	Tape/Reel
		AZ1084D-1.8	AZ1084D-1.8E1	AZ1084D-1.8	AZ1084D-1.8E1	Tube
		AZ1084D-1.8TR	AZ1084D-1.8TRE1	AZ1084D-1.8	AZ1084D-1.8E1	Tape/Reel
		AZ1084D-2.5	AZ1084D-2.5E1	AZ1084D-2.5	AZ1084D-2.5E1	Tube
		AZ1084D-2.5TR	AZ1084D-2.5TRE1	AZ1084D-2.5	AZ1084D-2.5E1	Tape/Reel
		AZ1084D-2.85	AZ1084D-2.85E1	AZ1084D-2.85	AZ1084D-2.85E1	Tube
		AZ1084D-2.85TR	AZ1084D-2.85TRE1	AZ1084D-2.85	AZ1084D-2.85E1	Tape/Reel
		AZ1084D-3.3	AZ1084D-3.3E1	AZ1084D-3.3	AZ1084D-3.3E1	Tube
		AZ1084D-3.3TR	AZ1084D-3.3TRE1	AZ1084D-3.3	AZ1084D-3.3E1	Tape/Reel
		AZ1084D-5.0	AZ1084D-5.0E1	AZ1084D-5.0	AZ1084D-5.0E1	Tube
		AZ1084D-5.0TR	AZ1084D-5.0TRE1	AZ1084D-5.0	AZ1084D-5.0E1	Tape/Reel
TO-220	0 to 125°C	AZ1084T-ADJ	AZ1084T-ADJE1	AZ1084T-ADJ	AZ1084T-ADJE1	Tube
		AZ1084T-1.5	AZ1084T-1.5E1	AZ1084T-1.5	AZ1084T-1.5E1	Tube
		AZ1084T-1.8	AZ1084T-1.8E1	AZ1084T-1.8	AZ1084T-1.8E1	Tube
		AZ1084T-2.5	AZ1084T-2.5E1	AZ1084T-2.5	AZ1084T-2.5E1	Tube
		AZ1084T-2.85	AZ1084T-2.85E1	AZ1084T-2.85	AZ1084T-2.85E1	Tube
		AZ1084T-3.3	AZ1084T-3.3E1	AZ1084T-3.3	AZ1084T-3.3E1	Tube
		AZ1084T-5.0	AZ1084T-5.0E1	AZ1084T-5.0	AZ1084T-5.0E1	Tube



**5A LOW DROPOUT LINEAR REGULATOR**

**AZ1084**

**Ordering Information (Continued)**

Package	Temperature Range	Part Number		Marking ID		Packing Type
		Tin Lead	LeadFree	Tin Lead	LeadFree	
TO-263-3L	0 to 125°C	AZ1084S-ADJ	AZ1084S-ADJE1	AZ1084S-ADJ	AZ1084S-ADJE1	Tube
		AZ1084S-ADJTR	AZ1084S-ADJTRE1	AZ1084S-ADJ	AZ1084S-ADJE1	Tape/Reel
		AZ1084S-1.5	AZ1084S-1.5E1	AZ1084S-1.5	AZ1084S-1.5E1	Tube
		AZ1084S-1.5TR	AZ1084S-1.5TRE1	AZ1084S-1.5	AZ1084S-1.5E1	Tape/Reel
		AZ1084S-1.8	AZ1084S-1.8E1	AZ1084S-1.8	AZ1084S-1.8E1	Tube
		AZ1084S-1.8TR	AZ1084S-1.8TRE1	AZ1084S-1.8	AZ1084S-1.8E1	Tape/Reel
		AZ1084S-2.5	AZ1084S-2.5E1	AZ1084S-2.5	AZ1084S-2.5E1	Tube
		AZ1084S-2.5TR	AZ1084S-2.5TRE1	AZ1084S-2.5	AZ1084S-2.5E1	Tape/Reel
		AZ1084S-2.85	AZ1084S-2.85E1	AZ1084S-2.85	AZ1084S-2.85E1	Tube
		AZ1084S-2.85TR	AZ1084S-2.85TRE1	AZ1084S-2.85	AZ1084S-2.85E1	Tape/Reel
		AZ1084S-3.3	AZ1084S-3.3E1	AZ1084S-3.3	AZ1084S-3.3E1	Tube
		AZ1084S-3.3TR	AZ1084S-3.3TRE1	AZ1084S-3.3	AZ1084S-3.3E1	Tape/Reel
		AZ1084S-5.0	AZ1084S-5.0E1	AZ1084S-5.0	AZ1084S-5.0E1	Tube
		AZ1084S-5.0TR	AZ1084S-5.0TRE1	AZ1084S-5.0	AZ1084S-5.0E1	Tape/Reel
TO-263-2L	0 to 125°C	AZ1084S2-ADJ	AZ1084S2-ADJE1	AZ1084S2-ADJ	AZ1084S2-ADJE1	Tube
		AZ1084S2-ADJTR	AZ1084S2-ADJTRE1	AZ1084S2-ADJ	AZ1084S2-ADJE1	Tape/Reel
		AZ1084S2-1.5	AZ1084S2-1.5E1	AZ1084S2-1.5	AZ1084S2-1.5E1	Tube
		AZ1084S2-1.5TR	AZ1084S2-1.5TRE1	AZ1084S2-1.5	AZ1084S2-1.5E1	Tape/Reel
		AZ1084S2-1.8	AZ1084S2-1.8E1	AZ1084S2-1.8	AZ1084S2-1.8E1	Tube
		AZ1084S2-1.8TR	AZ1084S2-1.8TRE1	AZ1084S2-1.8	AZ1084S2-1.8E1	Tape/Reel
		AZ1084S2-2.5	AZ1084S2-2.5E1	AZ1084S2-2.5	AZ1084S2-2.5E1	Tube
		AZ1084S2-2.5TR	AZ1084S2-2.5TRE1	AZ1084S2-2.5	AZ1084S2-2.5E1	Tape/Reel
		AZ1084S2-2.85	AZ1084S2-2.85E1	AZ1084S2-2.85	AZ1084S2-2.85E1	Tube
		AZ1084S2-2.85TR	AZ1084S2-2.85TRE1	AZ1084S2-2.85	AZ1084S2-2.85E1	Tape/Reel
		AZ1084S2-3.3	AZ1084S2-3.3E1	AZ1084S2-3.3	AZ1084S2-3.3E1	Tube
		AZ1084S2-3.3TR	AZ1084S2-3.3TRE1	AZ1084S2-3.3	AZ1084S2-3.3E1	Tape/Reel
		AZ1084S2-5.0	AZ1084S2-5.0E1	AZ1084S2-5.0	AZ1084S2-5.0E1	Tube
		AZ1084S2-5.0TR	AZ1084S2-5.0TRE1	AZ1084S2-5.0	AZ1084S2-5.0E1	Tape/Reel

The listed part numbers are used during the transition to lead-free products. After the transition completed, lead-free products will be considered as the "standard" and we will resume the original part numbers.

**5A LOW DROPOUT LINEAR REGULATOR****AZ1084****Absolute Maximum Ratings (Note 1)**

Parameter	Symbol	Min	Max	Unit
Operating Junction Temperature Range	$T_J$		150	$^{\circ}\text{C}$
Storage Temperature Range	$T_S$	-65	150	$^{\circ}\text{C}$
Lead Temperature (Soldering, 10 sec.)	$T_{\text{LEAD}}$		300	$^{\circ}\text{C}$
ESD (Human Body Model)	ESD		2000	V

Note 1: Stresses greater than those listed under "Absolute Maximum Ratings" may cause permanent damage to the device. These are stress ratings only, and functional operation of the device at these or any other conditions beyond those indicated under "Recommended Operating Conditions" is not implied. Exposure to "Absolute Maximum Ratings" for extended periods may affect device reliability.

**Recommended Operating Conditions**

Parameter	Symbol	Min	Max	Unit
Input Voltage	$V_{\text{IN}}$		12	V
Operating Junction Temperature Range	$T_J$	0	125	$^{\circ}\text{C}$



**5A LOW DROPOUT LINEAR REGULATOR**

**AZ1084**

**Electrical Characteristics**

Typicals and limits appearing in normal type apply for  $T_J = 25^\circ\text{C}$ . Limits appearing in **Boldface** type apply over the entire operating junction temperature range.

Parameter	Symbol	Conditions	Min	Typ	Max	Unit
Reference Voltage	$V_{REF}$	AZ1084-ADJ, $I_{OUT} = 10\text{mA}$ , $V_{IN} - V_{OUT} = 3\text{V}$ , $10\text{mA} \leq I_{OUT} \leq 5\text{A}$ , $1.5\text{V} \leq V_{IN} - V_{OUT} \leq 5\text{V}$	1.238 <b>1.225</b>	1.250 <b>1.250</b>	1.262 <b>1.270</b>	V
Output Voltage	$V_{OUT}$	AZ1084-1.5, $I_{OUT} = 0\text{mA}$ , $V_{IN} = 4.5\text{V}$ , $10\text{mA} \leq I_{OUT} \leq 5\text{A}$ , $3.1\text{V} \leq V_{IN} \leq 6\text{V}$	1.485 <b>1.47</b>	1.5 <b>1.5</b>	1.515 <b>1.53</b>	V
		AZ1084-1.8, $I_{OUT} = 0\text{mA}$ , $V_{IN} = 4.8\text{V}$ , $10\text{mA} \leq I_{OUT} \leq 5\text{A}$ , $3.4\text{V} \leq V_{IN} \leq 6\text{V}$	1.782 <b>1.764</b>	1.8 <b>1.8</b>	1.818 <b>1.836</b>	V
		AZ1084-2.5, $I_{OUT} = 0\text{mA}$ , $V_{IN} = 5.5\text{V}$ , $10\text{mA} \leq I_{OUT} \leq 5\text{A}$ , $4.1\text{V} \leq V_{IN} \leq 7\text{V}$	2.475 <b>2.45</b>	2.5 <b>2.5</b>	2.525 <b>2.55</b>	V
		AZ1084-2.85, $I_{OUT} = 0\text{mA}$ , $V_{IN} = 6\text{V}$ , $10\text{mA} \leq I_{OUT} \leq 5\text{A}$ , $4.5\text{V} \leq V_{IN} \leq 8\text{V}$	2.822 <b>2.793</b>	2.85 <b>2.85</b>	2.879 <b>2.907</b>	V
		AZ1084-3.3, $I_{OUT} = 0\text{mA}$ , $V_{IN} = 6.3\text{V}$ , $10\text{mA} \leq I_{OUT} \leq 5\text{A}$ , $4.9\text{V} \leq V_{IN} \leq 8\text{V}$	3.267 <b>3.234</b>	3.3 <b>3.3</b>	3.333 <b>3.366</b>	V
		AZ1084-5.0, $I_{OUT} = 0\text{mA}$ , $V_{IN} = 8\text{V}$ , $10\text{mA} \leq I_{OUT} \leq 5\text{A}$ , $6.6\text{V} \leq V_{IN} \leq 10\text{V}$	4.95 <b>4.9</b>	5 <b>5</b>	5.05 <b>5.1</b>	V
Line Regulation	$\Delta V_{OUT}$	AZ1084-ADJ, $I_{OUT} = 10\text{mA}$ , $2.85\text{V} \leq V_{IN} \leq 10\text{V}$		0.015 <b>0.035</b>	0.2 <b>0.2</b>	%
		AZ1084-1.5, $I_{OUT} = 10\text{mA}$ , $3.1\text{V} \leq V_{IN} \leq 10\text{V}$		0.5 <b>1</b>	6 <b>6</b>	mV
		AZ1084-1.8, $I_{OUT} = 10\text{mA}$ , $3.4\text{V} \leq V_{IN} \leq 10\text{V}$		0.5 <b>1</b>	6 <b>6</b>	mV
		AZ1084-2.5, $I_{OUT} = 10\text{mA}$ , $4.1\text{V} \leq V_{IN} \leq 10\text{V}$		0.5 <b>1</b>	6 <b>6</b>	mV
		AZ1084-2.85, $I_{OUT} = 10\text{mA}$ , $4.5\text{V} \leq V_{IN} \leq 10\text{V}$		0.5 <b>1</b>	6 <b>6</b>	mV
		AZ1084-3.3, $I_{OUT} = 10\text{mA}$ , $4.9\text{V} \leq V_{IN} \leq 10\text{V}$		0.5 <b>1</b>	6 <b>6</b>	mV
		AZ1084-5.0, $I_{OUT} = 10\text{mA}$ , $6.6\text{V} \leq V_{IN} \leq 10\text{V}$		0.5 <b>1</b>	10 <b>10</b>	mV



**5A LOW DROPOUT LINEAR REGULATOR**

**AZ1084**

**Electrical Characteristics (Continued)**

Typicals and limits appearing in normal type apply for  $T_J = 25^\circ\text{C}$ . Limits appearing in **Boldface** type apply over the entire operating junction temperature range.

Parameter	Symbol	Conditions	Min	Typ	Max	Unit
Load Regulation	$\Delta V_{OUT}$	AZ1084-ADJ, $0\text{mA} \leq I_{OUT} \leq 5\text{A}$ , $V_{IN} - V_{OUT} = 3\text{V}$		0.1 <b>0.2</b>	0.3 <b>0.4</b>	%
		AZ1084-1.5, $0\text{mA} \leq I_{OUT} \leq 5\text{A}$ , $V_{IN} - V_{OUT} = 3\text{V}$		3 <b>7</b>	15 <b>20</b>	mV
		AZ1084-1.8, $0\text{mA} \leq I_{OUT} \leq 5\text{A}$ , $V_{IN} - V_{OUT} = 3\text{V}$		3 <b>7</b>	15 <b>20</b>	mV
		AZ1084-2.5, $0\text{mA} \leq I_{OUT} \leq 5\text{A}$ , $V_{IN} - V_{OUT} = 3\text{V}$		3 <b>7</b>	15 <b>20</b>	mV
		AZ1084-2.85, $0\text{mA} \leq I_{OUT} \leq 5\text{A}$ , $V_{IN} - V_{OUT} = 3\text{V}$		3 <b>7</b>	15 <b>20</b>	mV
		AZ1084-3.3, $0\text{mA} \leq I_{OUT} \leq 5\text{A}$ , $V_{IN} - V_{OUT} = 3\text{V}$		3 <b>7</b>	15 <b>20</b>	mV
		AZ1084-5.0, $0\text{mA} \leq I_{OUT} \leq 5\text{A}$ , $V_{IN} - V_{OUT} = 3\text{V}$		5 <b>10</b>	20 <b>35</b>	mV
Dropout Voltage		$I_O = 5\text{A}$ , $\Delta V_{REF} \Delta V_{OUT} = 1\%$		1.3	1.5	V
Current Limit	$I_{LIMIT}$	$V_{IN} - V_{OUT} = 3\text{V}$ ,	5.5	6.5		A
Minimum Load Current		$V_{IN} = 10\text{V}$ (AZ1084-ADJ)		<b>3</b>	<b>10</b>	mA
Quiescent Current		$V_{IN} = 10\text{V}$ (AZ1084)		<b>5</b>	<b>10</b>	mA
Ripple Rejection		$f_{RIPPLE} = 120\text{Hz}$ , $C_{OUT} = 25\mu\text{F}$ Tantalum, $I_{OUT} = 5\text{A}$ , $V_{IN} - V_{OUT} = 3\text{V}$	<b>60</b>	<b>72</b>		dB
Adjust Pin Current		$V_{IN} = 4.25\text{V}$ , $I_{OUT} = 10\text{mA}$		55	<b>120</b>	$\mu\text{A}$
Adjust Pin Current Change		$10\text{mA} \leq I_{OUT} \leq 5\text{A}$ , $1.5\text{V} \leq (V_{IN} - V_{OUT}) \leq 4.5\text{V}$		<b>0.2</b>	<b>5</b>	$\mu\text{A}$
Temperature Stability		$I_{OUT} = 10\text{mA}$ , $V_{IN} - V_{OUT} = 1.5$		<b>0.5</b>		%
Long Term Stability		$T_A = 125^\circ\text{C}$ , 1000Hrs		0.5		%
RMS Noise (% of $V_{OUT}$ )		$10\text{Hz} \leq f \leq 10\text{kHz}$		0.003		%
Thermal Resistance Junction -to-Case	$\theta_{JC}$	TO-263 TO-220 TO-252		3 3		$^\circ\text{C} / \text{W}$



**5A LOW DROPOUT LINEAR REGULATOR**

**AZ1084**

**Typical Performance Characteristics**

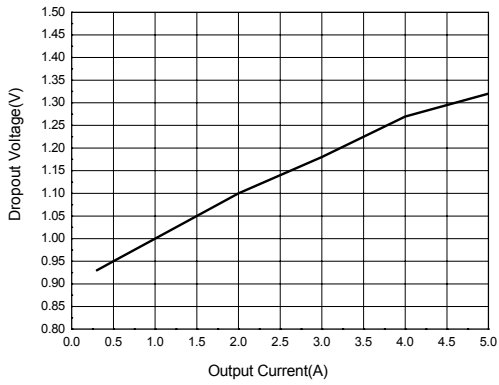

Figure 4. Dropout Voltage vs. Output Current

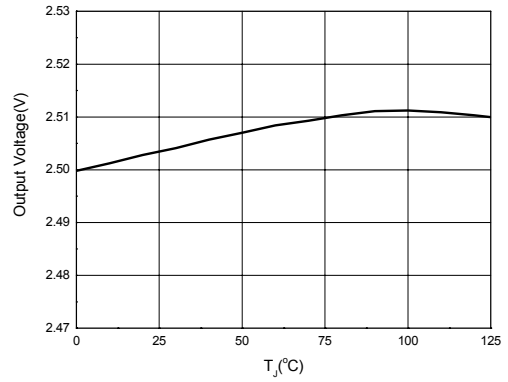

Figure 5. Output Voltage vs. Temperature

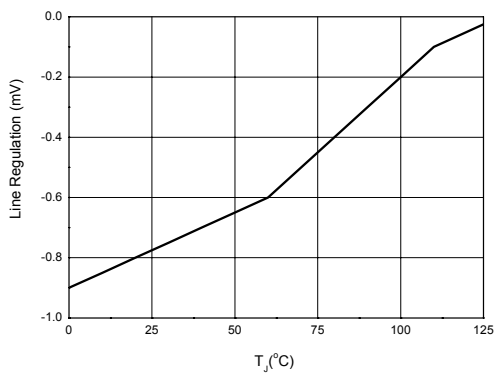

Figure 6. Line Regulation vs. Temperature

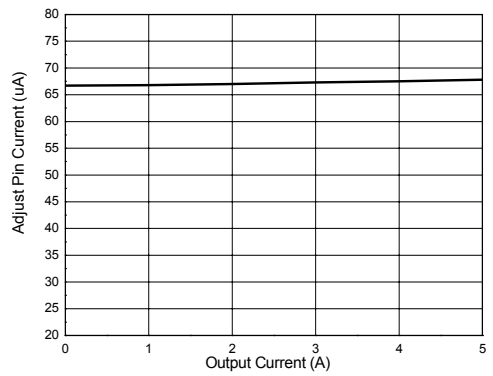

Figure 7. Adjust Pin Current vs. Output Current





**5A LOW DROPOUT LINEAR REGULATOR**

**AZ1084**

**Typical Performance Characteristics (Continued)**

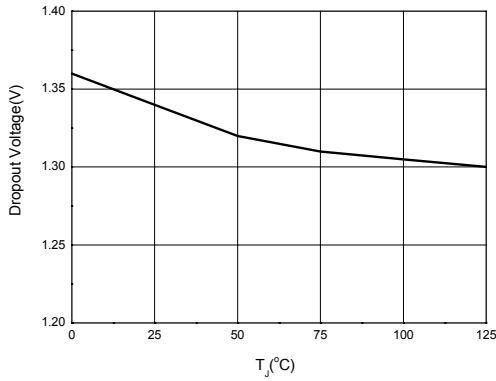

Figure 8. Dropout Voltage vs. Temperature

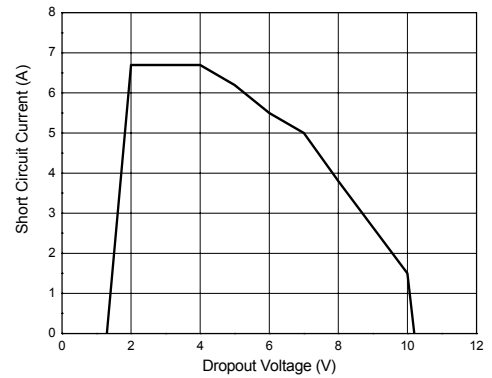

Figure 9. Short Circuit Current vs. Dropout Voltage

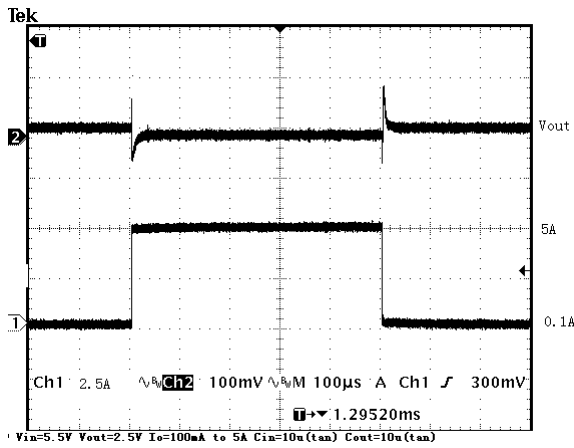

Figure 10. Load Transient Response

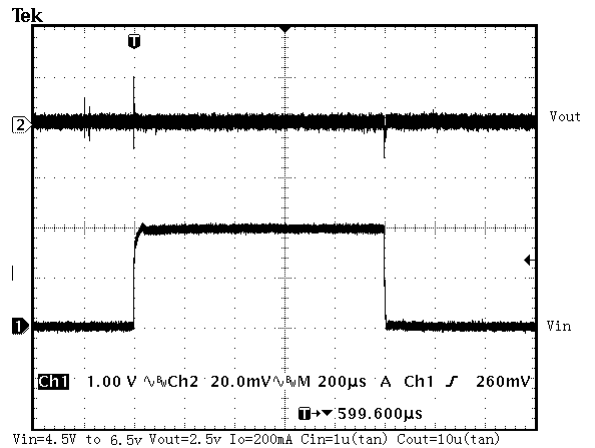

Figure 11. Line Transient Response



**5A LOW DROPOUT LINEAR REGULATOR**

**AZ1084**

**Typical Applications**

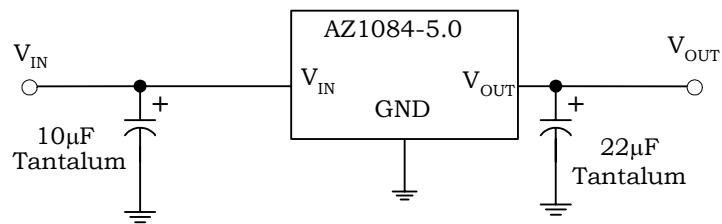
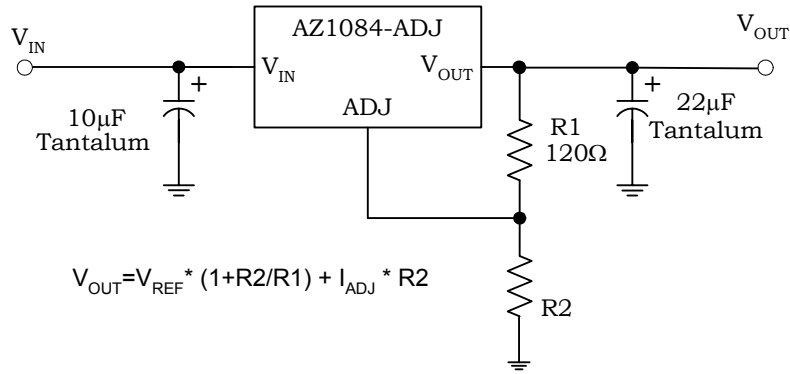

Figure 12. Typical Applications of AZ1084



**5A LOW DROPOUT LINEAR REGULATOR**

**AZ1084**

**Mechanical Dimensions**

**TO-263-3L**

**Unit: mm**

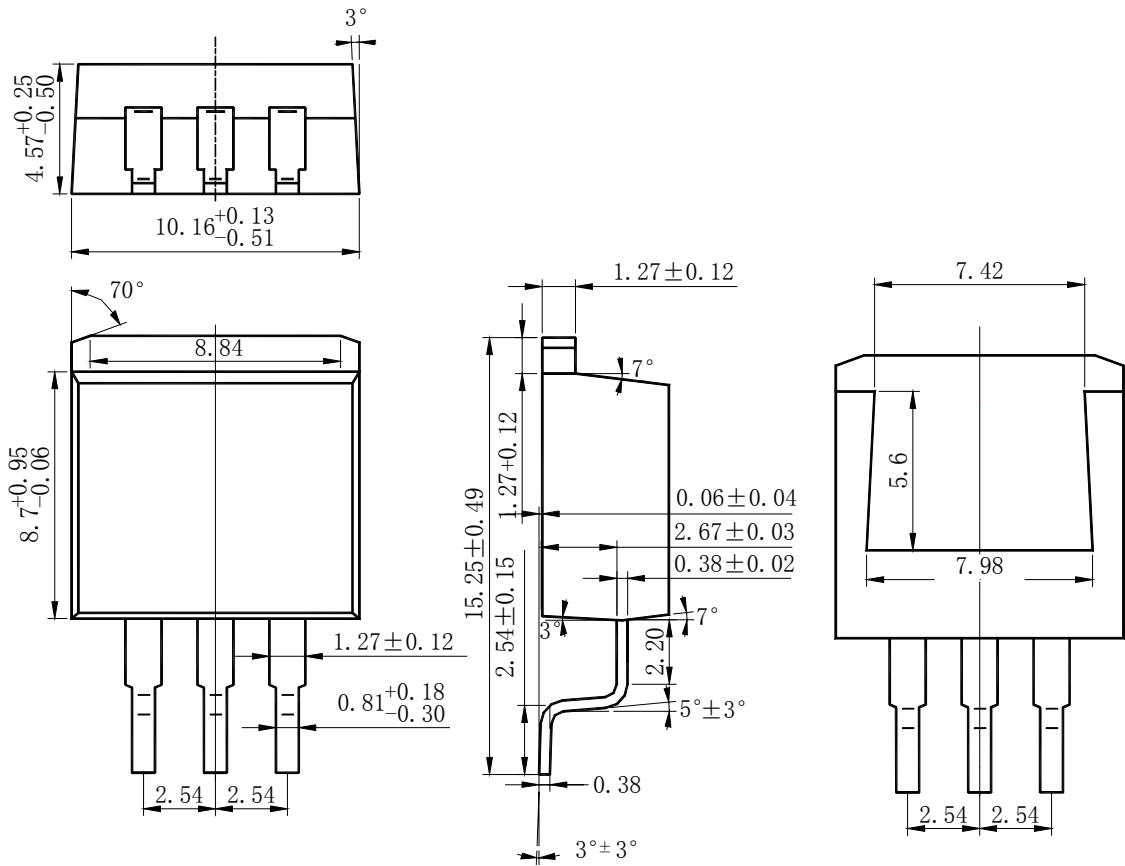



**5A LOW DROPOUT LINEAR REGULATOR**

**AZ1084**

**Mechanical Dimensions (Continued)**

**TO-263-2L**

**Unit: mm**

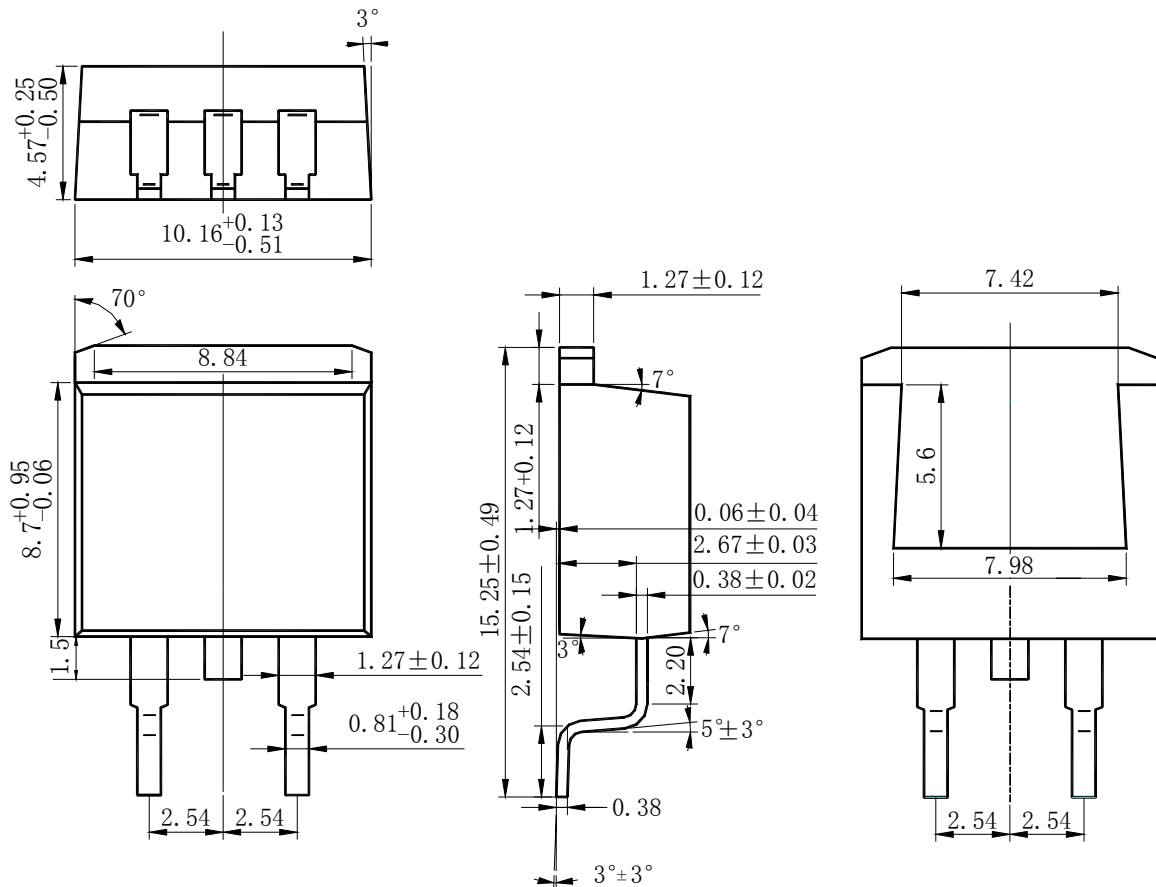



**5A LOW DROPOUT LINEAR REGULATOR**

**AZ1084**

**Mechanical Dimensions (Continued)**

**TO-220**

**Unit: mm**

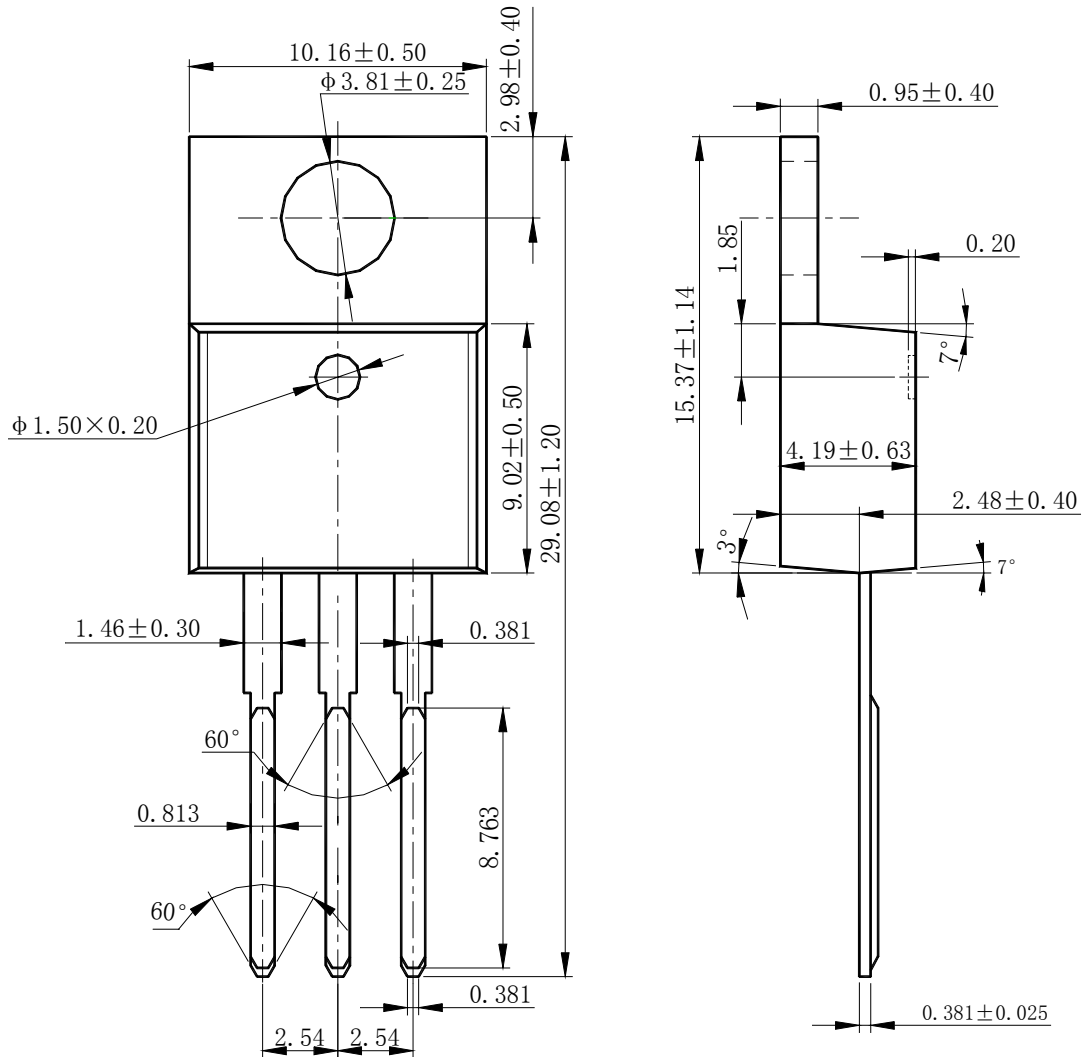





BCD Semiconductor Manufacturing Limited

<http://www.bcdsemi.com>

<http://www.aacmicro.com>

---

**BCD Semiconductor Corporation**

860 Hillview Court, Suite 160, Milpitas, CA 95035, USA

Tel: +1-408-586 8809, Fax: +1-408-586 8802

**Shanghai SIM-BCD Semiconductor manufacturing Co., Ltd.**

800 Yi Shan Road, Shanghai 200233, PRC

Tel: +86-21-6485-1491, Fax: +86-21-5450-0008

**Advanced Analog circuits (Shanghai) Corporation**

8F, B Zone, 900 Yi Shan Road, Shanghai 200233, PRC

Tel: +86-21-6495 9539, Fax: +86-21-6485 9673

**BCD Semiconductor (Taiwan) company Limited**

Room 2210, 22nd Fl, 333, Keelung Road, Sec. 1, TaiPei (110), Taiwan

Tel: +886-2-2758 6828, Fax: +886-2-2758 6892

**IMPORTANT NOTICE**

BCD Semiconductor Manufacturing Limited reserves the right to make changes without further notice to any products or specifications herein. BCD Semiconductor Manufacturing Limited does not assume any responsibility for use of any its products for any particular purpose, nor does BCD Semiconductor Manufacturing Limited assume any liability arising out of the application or use of any its products or circuits. BCD Semiconductor Manufacturing Limited does not convey any license under its patent rights or other rights nor the rights of others.