

通信继电器	TR5V
-------	------

- Designed for thermostat modem, computer peripherals, video recording and security applications
- Surge Strength 1500V FCC68
- Low coil power requirement for IC compatibility
- Terminals arranged on gird pattern
- Designed for compact, high density mounting
- Conform to RoHS, ELV directive

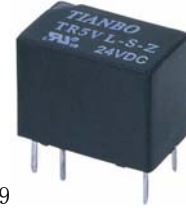
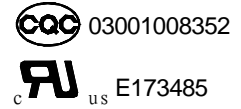

12.4×7.4×9.9

ORDERING CODE 订购代码

<u>TR5V</u> <u>D</u> — <u>S</u> — <u>Z</u> / <u>12VDC</u> 1 2 3 4 5	
1. Relay Model 继电器型号 2. Coil Power 线圈功率 D=0.36W, L=0.2W, M=0.15W, N=0.45W 3. S: Sealed 密封	4. 触点转换形式 Z Form C 5. Coil Nominal Voltage 线圈额定电压 3,5,6,9,12,24VDC

COIL DATA 线圈参数 (at 20°C)

Nominal Voltage 额定电压(VDC)	3	5	6	9	12	24	
Coil Resistance 线圈阻值(Ω ±10%)	60	167	240	540	960	3840	0.15W
Rated Current 额定电流(mA)	50	29.9	25	16.7	12.5	6.3	
Max Operate Voltage 最大吸合电压(VDC)	2.4	4	4.8	7.2	9.6	19.2	
Min Release Voltage 最小释放电压(VDC)	0.3	0.5	0.6	0.9	1.2	2.4	
Coil Resistance 线圈阻值(Ω ±10%)	45	125	180	405	720	2880	
Rated Current 额定电流(mA)	66.7	40	33.3	22.2	16.7	8.3	
Max Operate Voltage 最大吸合电压(VDC)	2.25	3.75	4.5	6.75	9	18	
Min Release Voltage 最小释放电压(VDC)	0.3	0.5	0.6	0.9	1.2	2.4	0.36W
Coil Resistance 线圈阻值(Ω ±10%)	25	70	100	220	400	1600	
Rated Current 额定电流(mA)	120	72	60	40	30	15	
Max Operate Voltage 最大吸合电压(VDC)	2.25	3.75	4.5	6.75	9	18	
Min Release Voltage 最小释放电压(VDC)	0.3	0.5	0.6	0.9	1.2	2.4	
Coil Resistance 线圈阻值(Ω ±10%)	20	56	80	180	320	1280	
Rated Current 额定电流(mA)	150	89.2	75	50	37.5	18.8	
Max Operate Voltage 最大吸合电压(VDC)	2.25	3.75	4.5	6.75	9	18	0.45W
Min Release Voltage 最小释放电压(VDC)	0.3	0.5	0.6	0.9	1.2	2.4	
Max Applicable Voltage 最大过载电压	70°C时额定电压的130%，23°C时额定电压的170%						

■ CONTACT DATA 触点参数

Contact Form触点形式	1Z	
Contact Material触点材料	Silver Alloy	
Load负载	Resistive load(COS Φ =1)	
Contact Ratings触点负载	1A 120VAC 1A 24VDC	2A 120VAC 2A 24VDC
Minimum load 最小负载	1mA 5VDC	
Max Switching Voltage最大转换电压	120VAC/60VDC	
Max Switching Current最大转换电流	1A	2A
Max Switching Power 最大转换功率	120VA/30W	240VA/48W
Contact Resistance接触电阻	100m Ω Max at 6VDC 1A	
Life Expectancy寿命	Electrical 电气寿命: 100,000 Operations(at30Operations/minute)	
	Mechanical机械寿命: 10,000,000 Operations(at300Operations/minute)	

■ CHARACTERISTICS DATA 性能参数

Insulation Resistance绝缘阻值	1000M Ω Min at 500VDC
Dielectric Strength Between Open Contacts触点间耐压	400VAC(for one minute)
Between Contacts and coil触点与线圈间耐压	1000VAC(for one minute)
Operate Time吸合时间	4ms
Release Time释放时间	3ms
Temperature Range环境温度	-30°C to +70°C
Shock Resistance冲击	Operating Extremes动作极限: 10G
	Damage Limits破坏极限: 100G
Vibration Resistance振动	10-55Hz, Double amplitude of 1.5mm
Max. switching frequency最大转换频率	Mechanical: 18,000operations/hr
	Electrical: 1,800operations/hr
Humidity湿度	35-85%
Weight重量	Approx 2.2g
Safety Standard安全标准	UL cUL CQC

■ APPROVED STANDARDS 安全标准

Model(型号)	Coiling rating (线圈电压)	Safety Standard (安全标准)	Contact rating (触点负载)
TR5V	3 to 24VDC	UL/cUL	2A 120VAC 2A 24VDC
		CQC	2A 120VAC 2A 24VDC

ENGINEERING DATA 设计参数

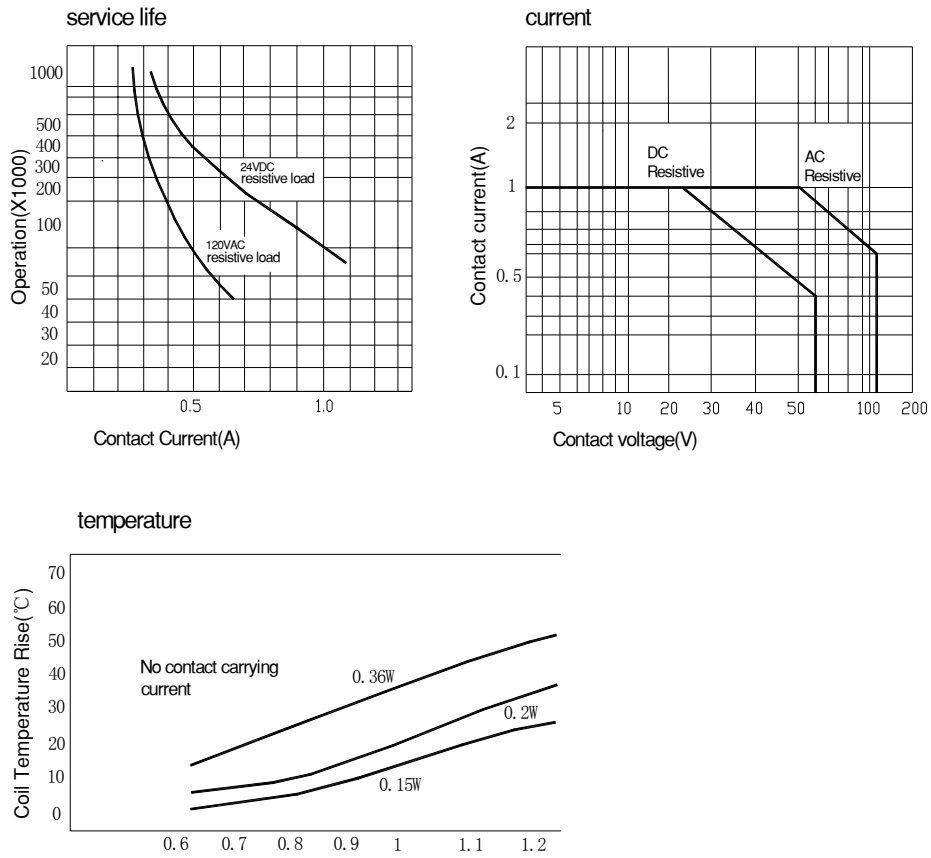

OVERALL AND MOUNTING DIMENSIONS 安装图

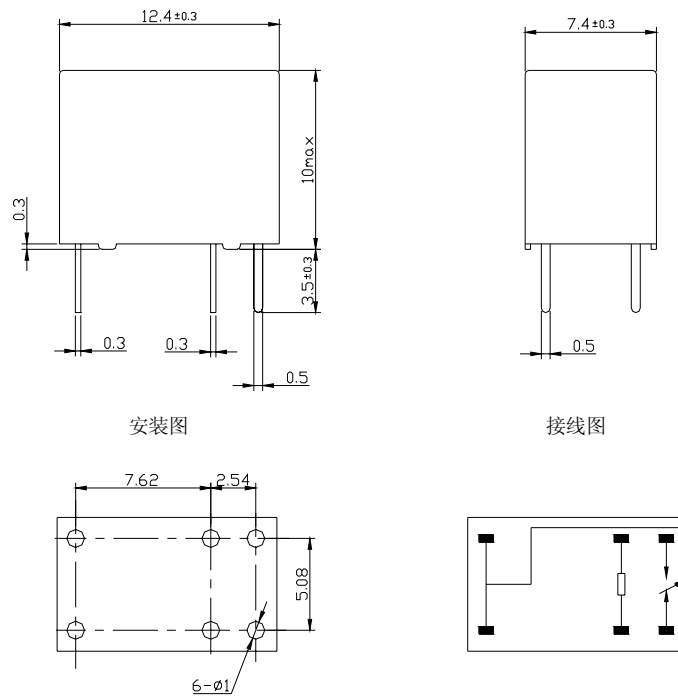

声明:

本产品规格书仅供客户使用时参考，如有更改，恕不另行通知。