



**300mA Low Dropout Linear Regulator**

■ **FEATURES**

- Low Dropout Voltage of 470mV at 300mA Output Current (3.0V Output Version).
- Guaranteed 300mA Output Current.
- Low Ground Current at 55µA.
- 2% Accuracy Output Voltage of 1.8V/ 2.0V /2.5V /2.7V/ 3.0V/ 3.3V/ 3.5V/ 3.7V/ 3.8V/ 5.0V/ 5.2V.
- Only needs 1µF Output Capacitor for Stability.
- Current and Thermal Limiting.

■ **APPLICATIONS**

- CD-ROM Drivers.
- LAN Cards.
- Microprocessor.
- RAM Module.
- Wireless Communication Systems.
- Battery Powered Systems.

■ **DESCRIPTION**

The AIC1734 is a 3-pin low dropout linear regulator. The superior characteristics of the AIC1734 include zero base current loss, very low dropout voltage, and 2% accuracy output voltage. Typical ground current remains approximately 55µA, for loading ranging from zero to maximum. Dropout voltage at 300mA output current is exceptionally low. Built-in output current limiting and thermal limiting provide maximal protection to the AIC1734 against fault conditions.

The AIC1734 is available in popular SOT-23, SOT-89 and TO-92 packages.

■ **TYPICAL APPLICATION CIRCUIT**

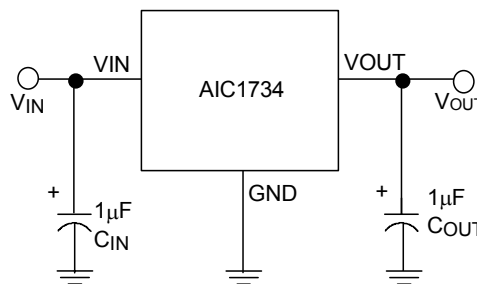

**Low Dropout Linear Regulator**

## ORDERING INFORMATION

AIC1734-XXXXX XX

PACKING TYPE  
TR: TAPE & REEL  
BG: BAG

PACKAGE TYPE  
U: SOT-23  
XA: SOT-89  
XT: SOT-89  
ZT: TO-92  
ZL: TO-92

C: Commercial  
P: Lead Free Commercial

OUTPUT VOLTAGE  
18: 1.8V  
20: 2.0V  
25: 2.5V  
27: 2.7V  
30: 3.0V  
33: 3.3V  
35: 3.5V  
37: 3.7V  
38: 3.8V  
50: 5.0V  
52: 5.2V

Example: AIC1734-18CXATR  
→ 1.8V Version, in SOT-89 Package & Tape & Reel Packing Type  
AIC1734-18PXATR  
→ 1.8V Version, in SOT-89 Lead Free Package & Tape & Reel Packing Type

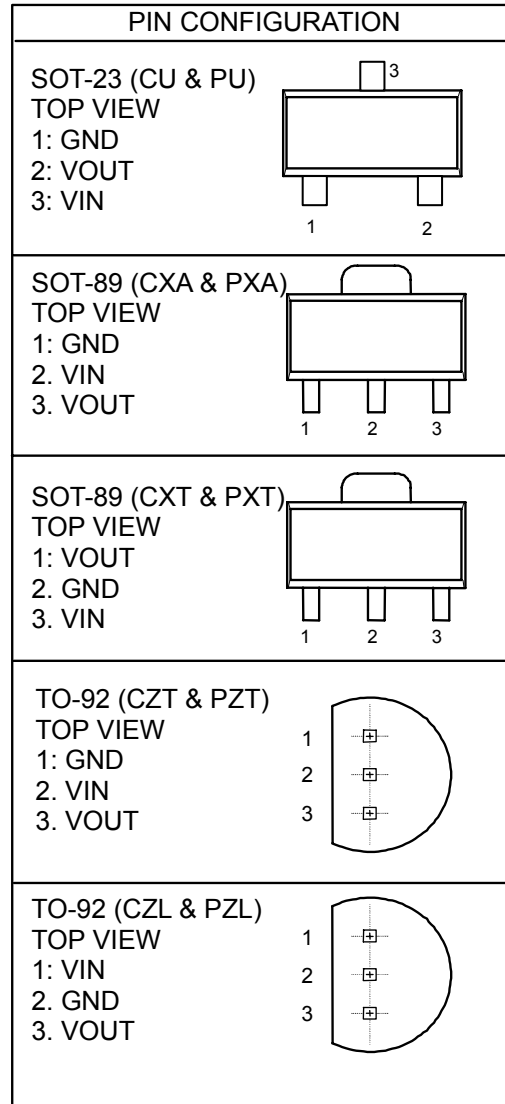

## SOT-23 MARKING

Part No.	CU	PU	Part No.	CU	PU
AIC1734-18XU	CD18	CD18P	AIC1734-35XU	CD35	CD35P
AIC1734-20XU	CD20	CD20P	AIC1734-37XU	CD37	CD37P
AIC1734-25XU	CD25	CD25P	AIC1734-38XU	CD38	CD38P
AIC1734-27XU	CD27	CD27P	AIC1734-50XU	CD50	CD50P
AIC1734-30XU	CD30	CD30P	AIC1734-52XU	CD52	CD52P
AIC1734-33XU	CD33	CD33P			

**● SOT-89 MARKING**

Part No.	CXA	PXA	Part No.	CXT	PXT
AIC1734-18XXA	CA18	CA18P	AIC1734-18XXT	CB18	CB18P
AIC1734-20XXA	CA20	CA20P	AIC1734-20XXT	CB20	CB20P
AIC1734-25XXA	CA25	CA25P	AIC1734-25XXT	CB25	CB25P
AIC1734-27XXA	CA27	CA27P	AIC1734-27XXT	CB27	CB27P
AIC1734-30XXA	CA30	CA30P	AIC1734-30XXT	CB30	CB30P
AIC1734-33XXA	CA33	CA33P	AIC1734-33XXT	CB33	CB33P
AIC1734-35XXA	CA35	CA35P	AIC1734-35XXT	CB35	CB35P
AIC1734-37XXA	CA37	CA37P	AIC1734-37XXT	CB37	CB37P
AIC1734-38XXA	CA38	CA38P	AIC1734-38XXT	CB38	CB38P
AIC1734-50XXA	CA50	CA50P	AIC1734-50XXT	CB50	CB50P
AIC1734-52XXA	CA52	CA52P	AIC1734-52XXT	CB52	CB52P

**■ ABSOLUTE MAXIMUM RATINGS**

Input Supply Voltage.....-0.3 ~12V  
 Operating Temperature Range.....-40°C~ 85°C  
 Storage Temperature Range .....-65°C~150°C  
 Maximum Junction Temperature.....125°C  
 Lead Temperature (Soldering) 10 sec.....260°C

Thermal Resistance Junction to Ambient SOT-89 Package.....160°C/W  
 (Assume no Ambient Airflow, no Heatsink) TO-92 Package.....150°C/W  
 SOT-23 Package.....180°C/W

**Absolute Maximum Ratings are those values beyond which the life of a device may be impaired.**

**■ TEST CIRCUIT**

Refer to the TYPICAL APPLICATION CIRCUIT

■ **ELECTRICAL CHARACTERISTICS** ( $T_A=25^{\circ}\text{C}$ ,  $C_{IN}=1\mu\text{F}$ ,  $C_{OUT}=1\mu\text{F}$ , unless otherwise specified.)

PARAMETER	TEST CONDITIONS	MIN.	TYP.	MAX.	UNIT	
Output Voltage	No Load					
	AIC1734-52	$V_{IN}=5.5\sim 12\text{V}$	5.100	5.200	5.300	V
	AIC1734-50	$V_{IN}=5.5\sim 12\text{V}$	4.900	5.000	5.100	
	AIC1734-38	$V_{IN}=4.1\sim 12\text{V}$	3.725	3.800	3.875	
	AIC1734-37	$V_{IN}=4.0\sim 12\text{V}$	3.625	3.700	3.775	
	AIC1734-35	$V_{IN}=4.0\sim 12\text{V}$	3.430	3.500	3.570	
	AIC1734-33	$V_{IN}=4.0\sim 12\text{V}$	3.235	3.300	3.365	
	AIC1734-30	$V_{IN}=4.0\sim 12\text{V}$	2.940	3.000	3.060	
	AIC1734-27	$V_{IN}=4.0\sim 12\text{V}$	2.646	2.700	2.754	
	AIC1734-25	$V_{IN}=4.0\sim 12\text{V}$	2.450	2.500	2.550	
	AIC1734-20	$V_{IN}=4.0\sim 12\text{V}$	1.960	2.000	2.040	
AIC1734-18	$V_{IN}=4.0\sim 12\text{V}$	1.764	1.800	1.836		
Output Voltage Temperature Coefficiency	(Note 1)		50		PPM/ $^{\circ}\text{C}$	
Line Regulation	$I_L=1\text{mA}$ , $1.4\text{V}\leq V_{OUT}\leq 3.2\text{V}$	$V_{IN}=4\text{V}\sim 12\text{V}$		3	10	mV
	$3.3\text{V}\leq V_{OUT}\leq 5.2\text{V}$	$V_{IN}=5.5\text{V}\sim 12\text{V}$		3	10	
Load Regulation (Note 2)	$I_L=0.1\sim 300\text{mA}$ , $1.4\text{V}\leq V_{OUT}\leq 3.9\text{V}$	$V_{IN}=5\text{V}$		7	20	mV
	$4.0\text{V}\leq V_{OUT}\leq 5.2\text{V}$	$V_{IN}=7\text{V}$		15	40	
Current Limit (Note 3)	$V_{IN}=7\text{V}$ , $V_{OUT}=0\text{V}$		300		mA	
Dropout Voltage (Note 4)	$I_L=300\text{mA}$	$4.0\text{V}\leq V_{OUT}\leq 5.2\text{V}$		400		mV
		$3.0\text{V}\leq V_{OUT}\leq 3.9\text{V}$		470		
		$2.5\text{V}\leq V_{OUT}\leq 2.9\text{V}$		570		
		$2.0\text{V}\leq V_{OUT}\leq 2.4\text{V}$		800		
		$1.4\text{V}\leq V_{OUT}\leq 1.9\text{V}$		1260		
Ground Current	$I_O=0.1\text{mA}\sim I_{MAX}$ , $1.4\text{V}\leq V_{OUT}\leq 3.9\text{V}$	$V_{IN}=5\sim 12\text{V}$		55	80	$\mu\text{A}$
	$4.0\text{V}\leq V_{OUT}\leq 5.2\text{V}$	$V_{IN}=7\sim 12\text{V}$		55	80	

Note 1: Guaranteed by design.

Note 2: Regulation is measured at constant junction temperature, using pulse testing with a low ON time.

Note 3: Current limit is measured by pulsing a short time.

Note 4: Dropout voltage is defined as the input to output differential at which the output voltage drops 100mV.

Note5: Specifications are guaranteed by Statistical Quality Controls (SQC), with no production test proved, when operating temperature ranges from  $-40^{\circ}\text{C}$  to  $85^{\circ}\text{C}$ .

**TYPICAL PERFORMANCE CHARACTERISTICS**

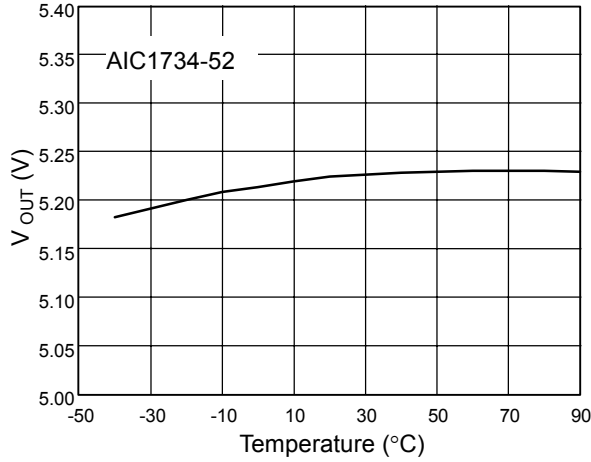

Fig. 1 V<sub>OUT</sub> vs. Temperature

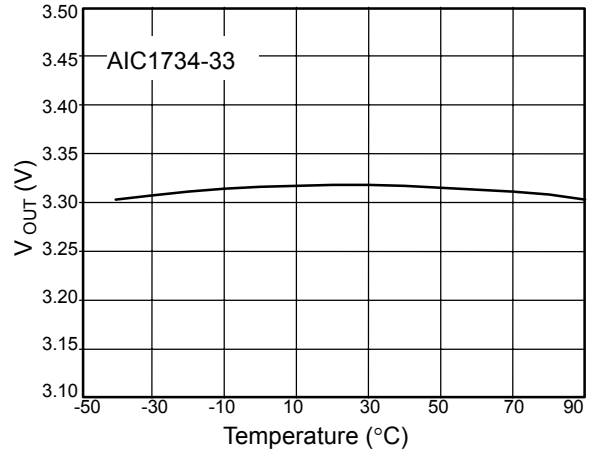

Fig. 2 V<sub>OUT</sub> vs. Temperature

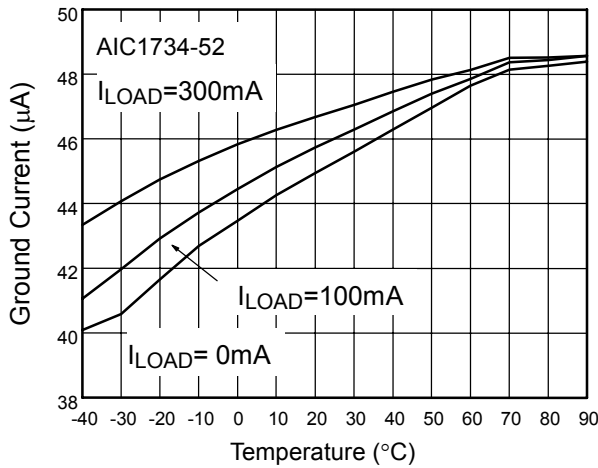

Fig. 3 Ground Current vs. Temperature

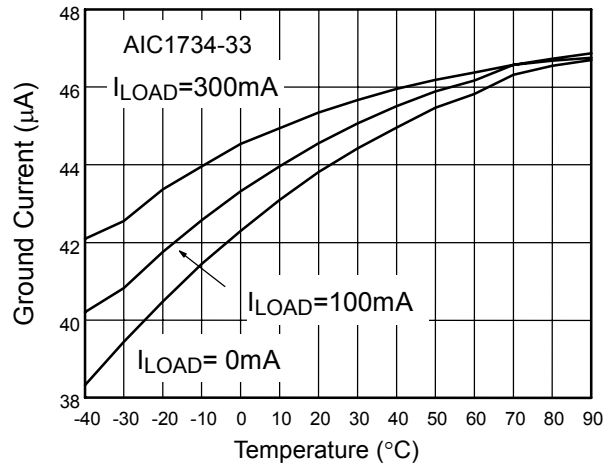

Fig. 4 Ground Current vs. Temperature

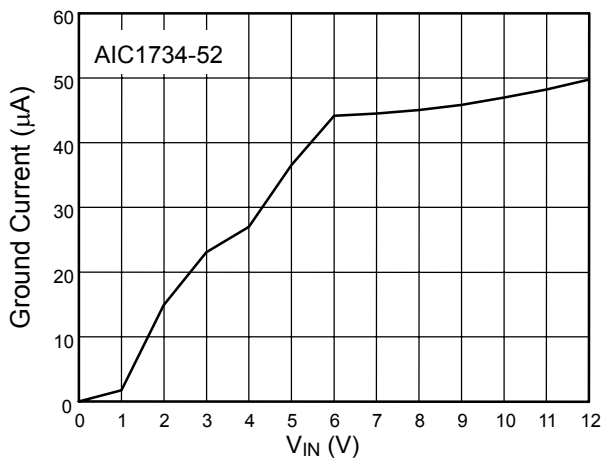

Fig. 5 Ground Current vs. V<sub>IN</sub>

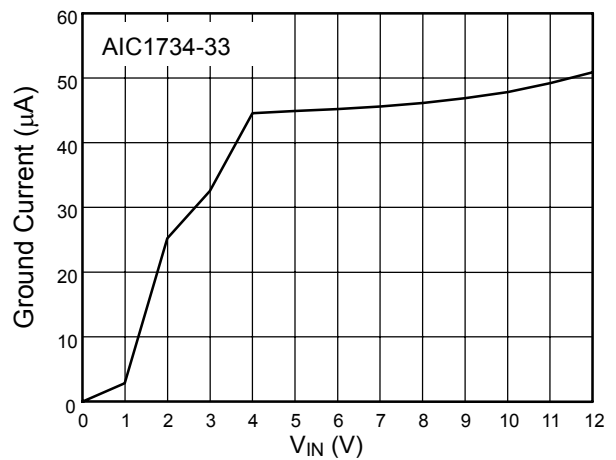

Fig. 6 Ground Current vs. V<sub>IN</sub>

■ TYPICAL PERFORMANCE CHARACTERISTIC (Continued)

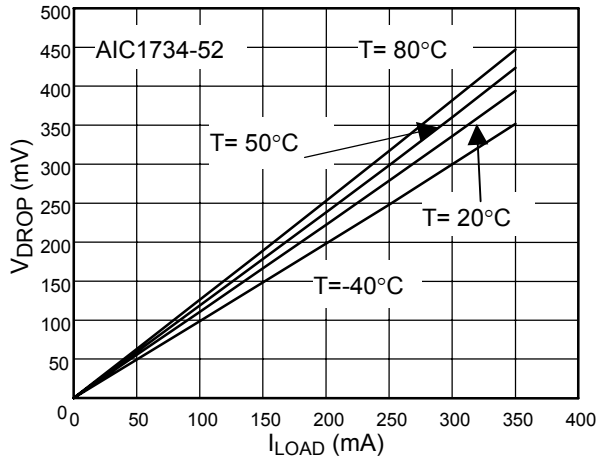

Fig. 7 V<sub>DROP</sub> vs. I<sub>LOAD</sub>

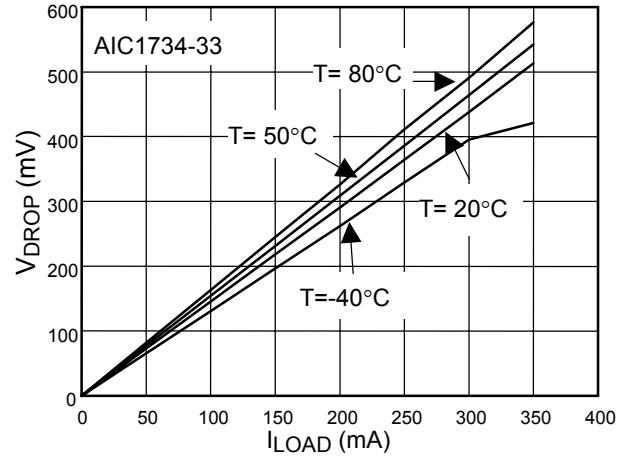

Fig. 8 V<sub>DROP</sub> vs. I<sub>LOAD</sub>

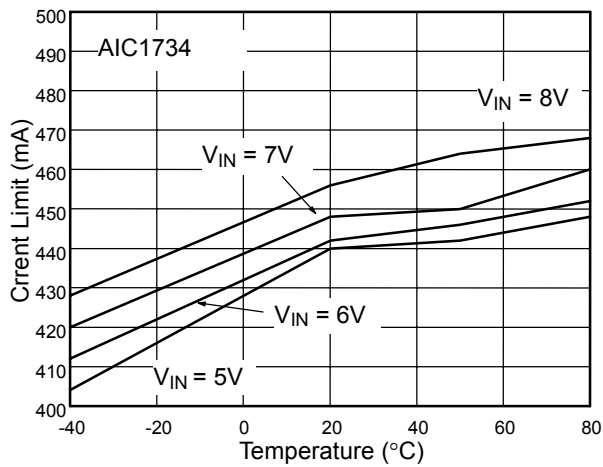
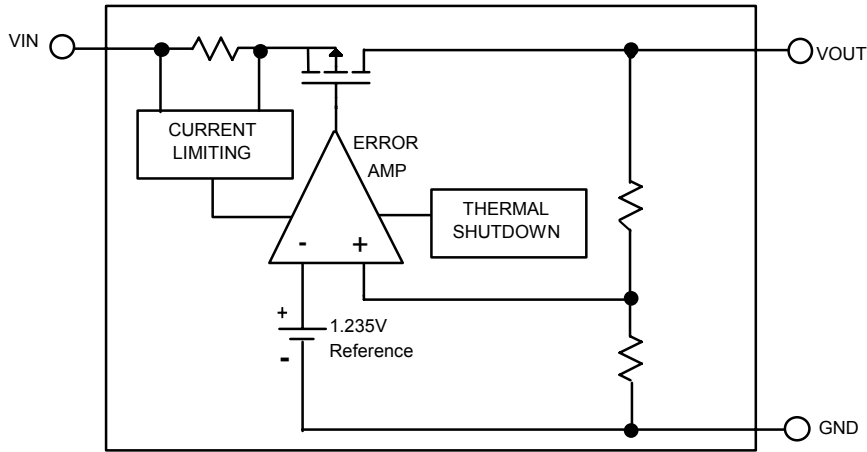

Fig. 9 Current Limit vs. Temperature

**■ BLOCK DIAGRAM**



**■ PIN DESCRIPTIONS**

VOUT PIN - Output pin.

GND PIN - Power GND.

VIN PIN - Power Supply Input.

■ PHYSICAL DIMENSIONS (unit: mm)

● SOT-23

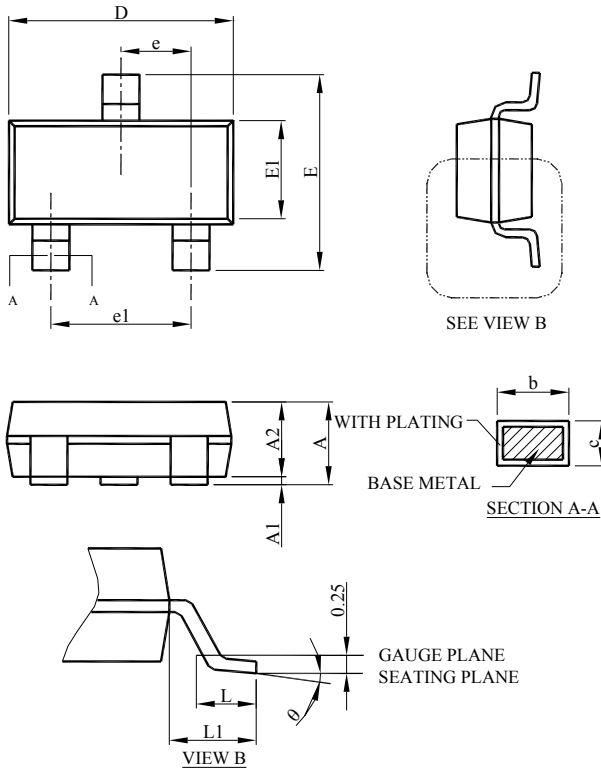

SYMBOL	SOT-23	
	MILLIMETERS	
	MIN.	MAX.
A	0.95	1.45
A1	0.05	0.15
A2	0.90	1.30
b	0.30	0.50
c	0.08	0.22
D	2.80	3.00
E	2.60	3.00
E1	1.50	1.70
e	0.95 BSC	
e1	1.90 BSC	
L	0.30	0.60
L1	0.60 REF	
$\theta$	0°	8°

● SOT-89

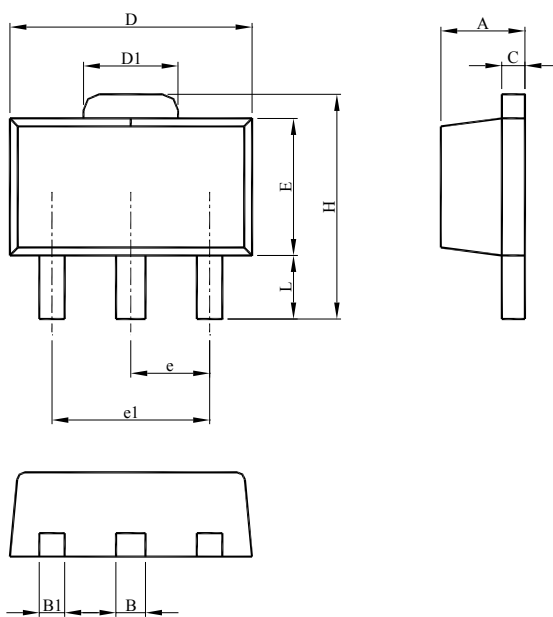

SYMBOL	SOT-89	
	MILLIMETERS	
	MIN.	MAX.
A	1.40	1.60
B	0.44	0.56
B1	0.36	0.48
C	0.35	0.44
D	4.40	4.60
D1	1.50	1.83
E	2.29	2.60
e	1.50 BSC	
e1	3.00 BSC	
H	3.94	4.25
L	0.89	1.20



● TO-92

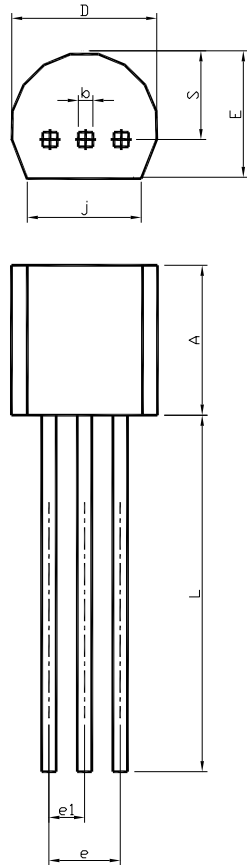

SYMBOL	TO-92	
	MILLIMETERS	
	MIN.	MAX.
A	4.32	5.33
b	0.36	0.47
D	4.45	5.20
E	3.18	4.19
e	2.42	2.66
e1	1.15	1.39
j	3.43	
L	12.70	
S	2.03	2.66

**Note:**

Information provided by AIC is believed to be accurate and reliable. However, we cannot assume responsibility for use of any circuitry other than circuitry entirely embodied in an AIC product; nor for any infringement of patents or other rights of third parties that may result from its use. We reserve the right to change the circuitry and specifications without notice.

Life Support Policy: AIC does not authorize any AIC product for use in life support devices and/or systems. Life support devices or systems are devices or systems which, (i) are intended for surgical implant into the body or (ii) support or sustain life, and whose failure to perform, when properly used in accordance with instructions for use provided in the labeling, can be reasonably expected to result in a significant injury to the user.