

AVLC 0201 series

Ultra Compact Size Multilayer Chip Varistor



Overview

ESD Varistor is a component which acts as a non-conductor on the circuit in normal circumstances. When over-voltage is loaded, it becomes a conductor which diverts over-current from circuits to ground at critical voltage level. Especially, new ultra compact size chip varistor with 0.6x0.3mm dimension can save design space in mobile phone and show even enhanced ESD performance.

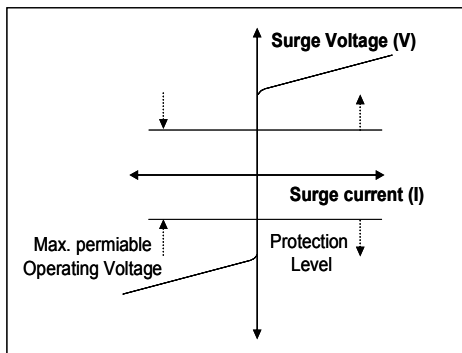

Fig 1 V-I Characteristic Curve

Features

- Ultra small size (0201 : 0.6x0.3mm)
- Meets IEC 61000-4-2(ESD) level 4 requirements
- ESD Protection > 15kV
- Low capacitance for high frequency data line protection
- Fast response time < 1ns
- Available in tape and reel for automatic pick and place

Applications

- Electronic alliance for protection on ESD.
- LCD Module
- Mobile phone/PDAs
- MP3 Player
- Digital Camera
- ESD Protection for sensitive IC
- I / O Port, Keypad
- Wireless Handsets
- Lap top Computer
- Desk top Computer
- Notebook

Model Description

AVLC	5	S	01	015
(1)	(2)	(3)	(4)	(5)

- (1) Series name : "AVLC" – Low capacitance type varistor
- (2) Maximum continuous working voltage (Vdc) : "5"- 5.5V
- (3) Varistor voltage tolerance : "S" - special order
- (4) Chip size : 01 means 0201 (0.6 x 0.3 mm)
- (5) Capacitance : 015 means 15pF (typical)

AVLC 0201 series

Ultra Compact Size Multilayer Chip Varistor



Electrical characteristics

Part No.	Vdc(1)	Varistor voltage at 1mA DC	IL (at Vdc)	Cp (at 1kHz, Vrms=0.5V)	Clamping Voltage	Peak Current	Transient Energy	IR (at 3.6V DC)
	(V)							
AVLC 5S 01 015	5.5	10 ~ 15.6	50	15 (10.5 ~ 19.5)	Max. 35	Max.1	Max. 0.01	Min. 10
AVLC 5S 01 033				33 (23.1 ~ 42.9)				
AVLC 5S 01 050				50 (35.0 ~ 65.0)		Max.5		
AVLC 5S 01 100				100 (70.0 ~ 100.0)				

(1) Maximum continuous DC working voltage

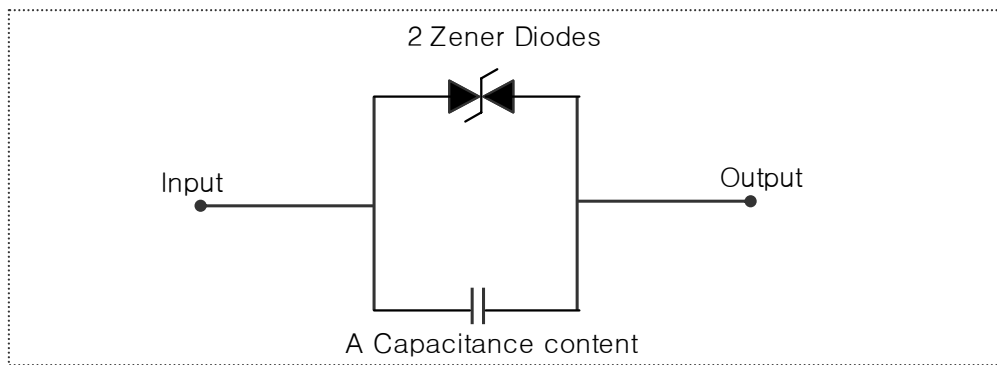
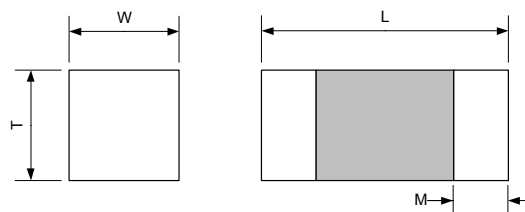

Fig.2 Equivalent Circuit

Appearance



Size(mm)	L	W	T	M
0603	0.60 ± 0.03	0.30 ± 0.03	0.30 ± 0.03	Min 0.1.

AVLC 0201 series

Ultra Compact Size Multilayer Chip Varistor



Recommended Land pattern (Typical Dimensions)

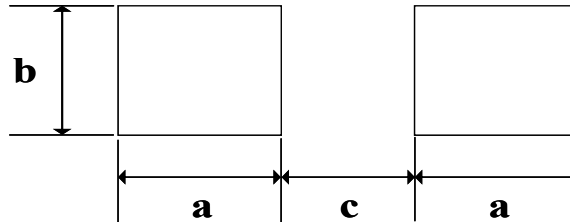

Size(mm)	a	b	c
0603	0.2 ~ 0.3	0.25 ~ 0.35	0.25 ~ 0.35

Recommended Soldering Profile

- Pb Free Solder Paste : Sn / Ag / Cu (96.5 / 3.0 / 0.5)

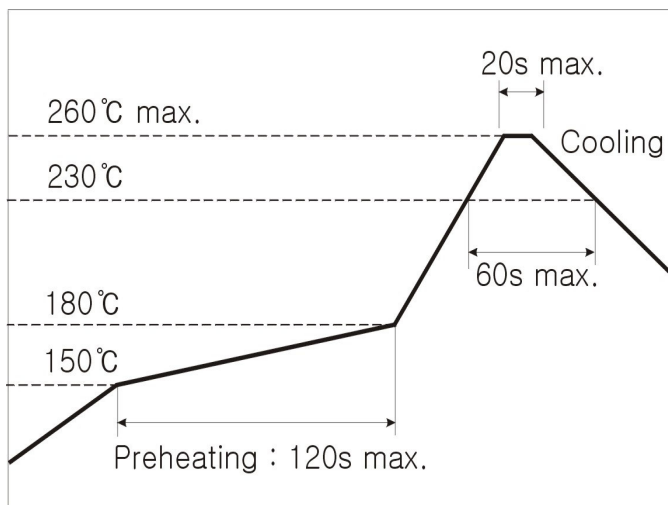

AVLC 0201 series

Ultra Compact Size Multilayer Chip Varistor



ESD Absorption Characteristics (Typical data)

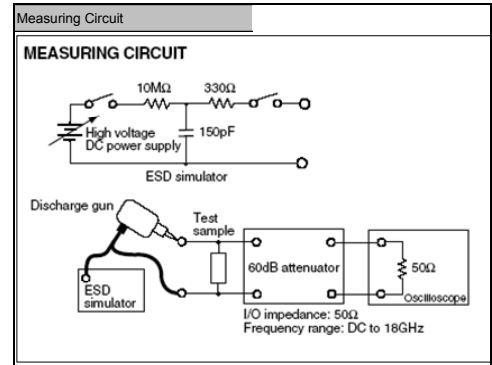
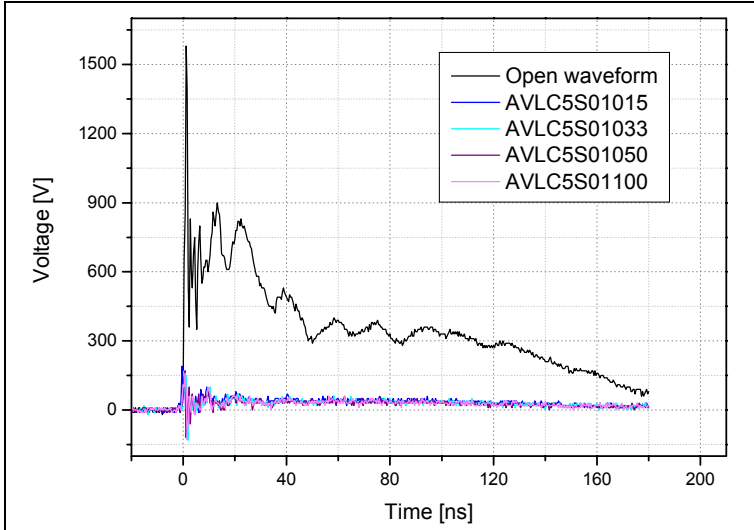

Model	Open Waveform	AVLC 5S 01 015	AVLC 5S 01 033	AVLC 5S 01 050	AVLC 5S 01 100
Peak Voltage	1580 V	190 V	170 V	170 V	160 V
Average Voltage (30ns to 100ns)	372 V	42 V	37 V	34 V	34 V

ESD TESTS

TEST CONDITIONS

150pF , 330 Ω contact discharge
Charged voltage : 8kV, 0.1s interval

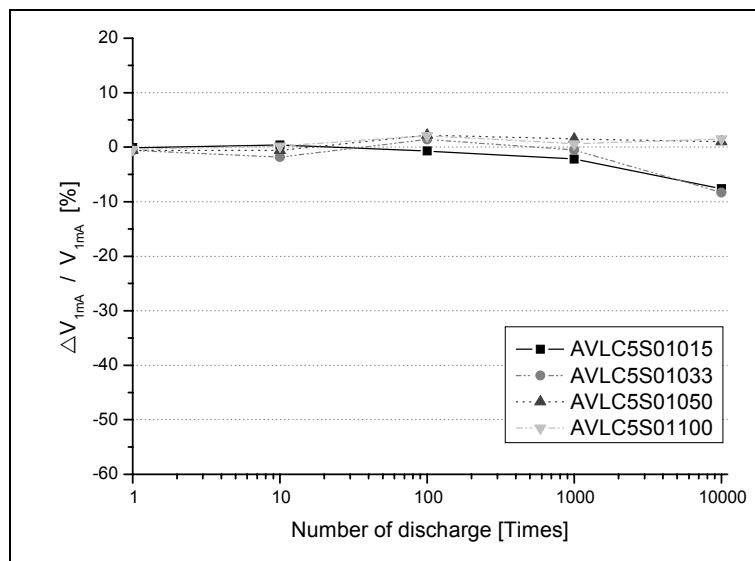

AVLC 0201 series

Ultra Compact Size Multilayer Chip Varistor



CAPACITANCE vs. FREQUENCY CHARACTERISTICS

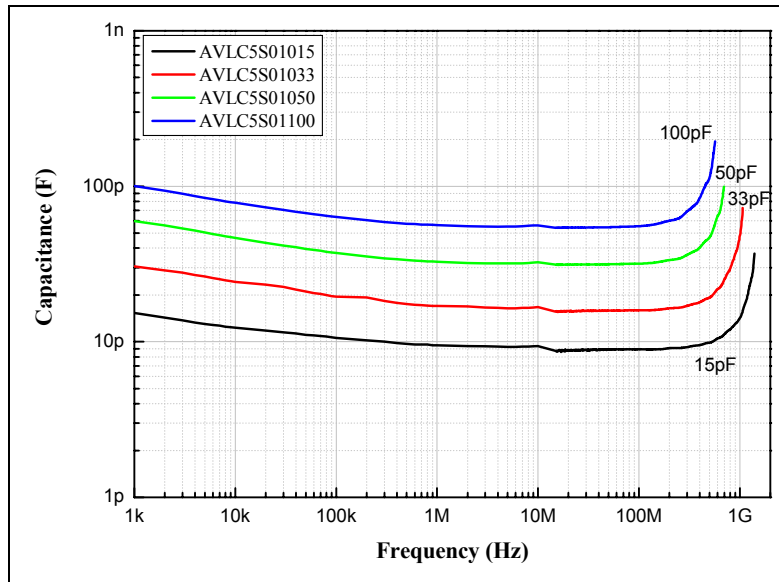

TRANSMISSION CHARACTERISTICS

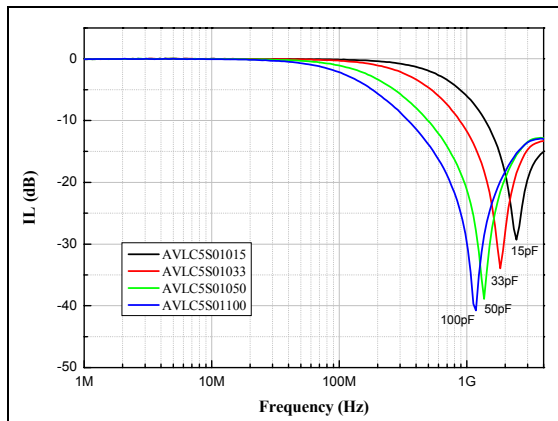

IMPEDANCE vs. FREQUENCY CHARACTERISTICS

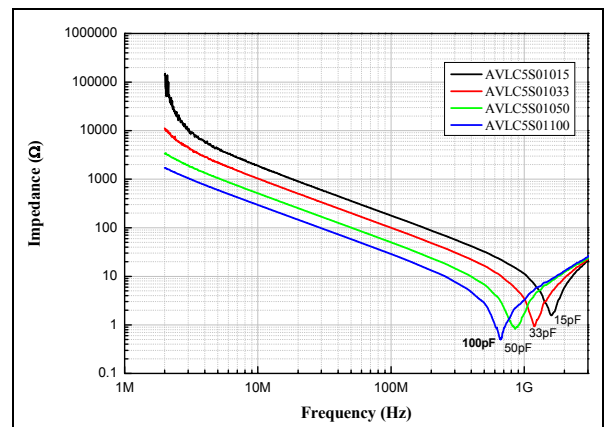

AVL/AVLC 0402 Series Multilayer Chip Varistor



Overview

ESD Varistor is a component which acts as a non-conductor on the circuit in normal circumstances. When over-voltage is loaded, it becomes a conductor which diverts over-current from circuits to ground at critical voltage level.

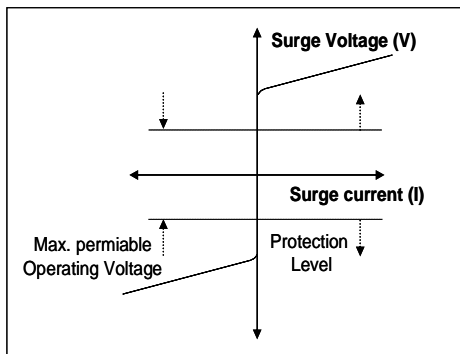

Fig 1 V-I Characteristic Curve

Features

- Meets IEC 61000-4-2 (ESD)
- Level 4 & IEC 61000-4-4 (EFT), Level 4 requirements
- ESD Protection > 25 KV
- Low capacitance for high frequency data line protection
- Fast response time < 1ns
- Available in tape and reel for automatic pick and place

Applications

- Mobile Phone & PDA
- Cellular Phone
- PCMCIA / Compact Flash Card
- RS-232 & RS-423 Data Lines
- USB Data Lines
- MCM Boards
- LCD Module

Model Description

AVLC **5** **S** **02** **050**
(1) **(2)** **(3)** **(4)** **(5)**

- (1) Series name : "AVL" – General Type
"AVLC" – Low capacitance type varistor
- (2) Maximum continuous working voltage (Vdc) : "5"- 5.5V, "14"- 14V, "18"- 18V
- (3) Breakdown voltage tolerance : "S" - special order, M: 20 % Vn tolerance
- (4) Chip size : 02 - 0402(1.0x0.5mm), 03 - 0603(1.6x0.8mm)
- (5) Peak current (AVL) : 200 - 20 A
Capacitance (AVLC) : 003-3pF, 015-15pF, 050-50pF, 100-100pF, 200-200pF

AVL/AVLC 0402 Series Multilayer Chip Varistor



Electrical characteristics

Part No.	Vdc ⁽¹⁾	Varistor voltage (Vn) @1mA DC	Leakage Current (IL) @Vdc	Cp (@ 1kHz, V _{rms} =0.5V)	Clamping Voltage (VC)	Peak Current (Imax)	Insulation Resistance (IR) @3.6V
	(V)	(V)	(μ A)	(pF)	(V)	(A)	(M Ω)
AVL 5M 02 200	5.5	6.4-9.6	20 max	480(336-624)	15.5	20	10 min
AVL 14K 02 200	14	16.2-19.8	20 max	160(112-208)	35	20	10 min
AVLC 5S 02 050	5.5	10-14	20 max	50 (35-65)	25	10	10 min
AVLC 5S 02 100	5.5	10-14	20 max	100 (70-130)	25	20	10 min
AVLC 5S 02 200	5.5	10-14	20 max	200 (140-260)	25	20	10 min
AVLC 14S 02 050	14	18-24	20 max	50 (35-65)	40	10	10 min
AVLC 14S 02 100	14	18-24	20 max	100 (70-130)	40	20	10 min
AVLC 18S 02 015	18	24-32	20 max	15 (7.5-22.5)	45	5	10 min
AVLC 18S 02 003	18	90-160	20 max	3.0 (2.1-3.9) at 1MHz	300	1	10 min

(1) Maximum continuous DC working voltage

(2) Cp measuring frequency of AVLC 18S 02 003 is 1 MHz

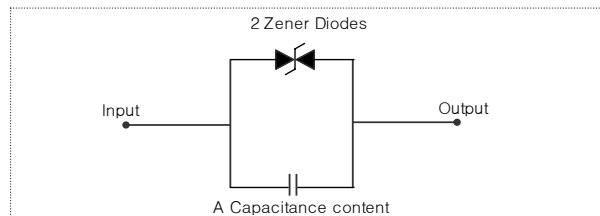
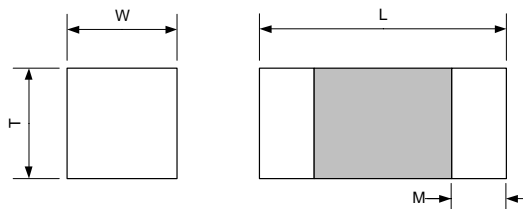

Fig.2 Equivalent Circuit

Appearance



Symbol	L	W	T	M
Size (mm)	1.0 ± 0.10	0.5 ± 0.10	Max. 0.6	0.2 ± 0.10

AVL/AVLC 0402 Series Multilayer Chip Varistor



Recommended Land pattern (Typical Dimensions)

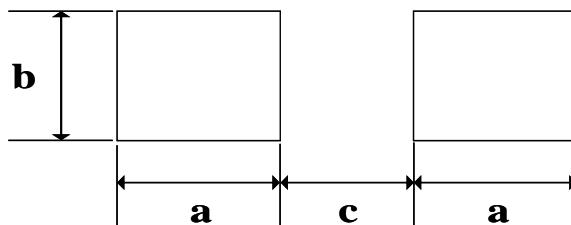

Symbol	a	b	c
Size (mm)	0.61	0.51	0.51

Recommended Soldering Profile

- Pb Free Solder Paste : Sn / Ag / Cu (96.5 / 3.0 / 0.5)

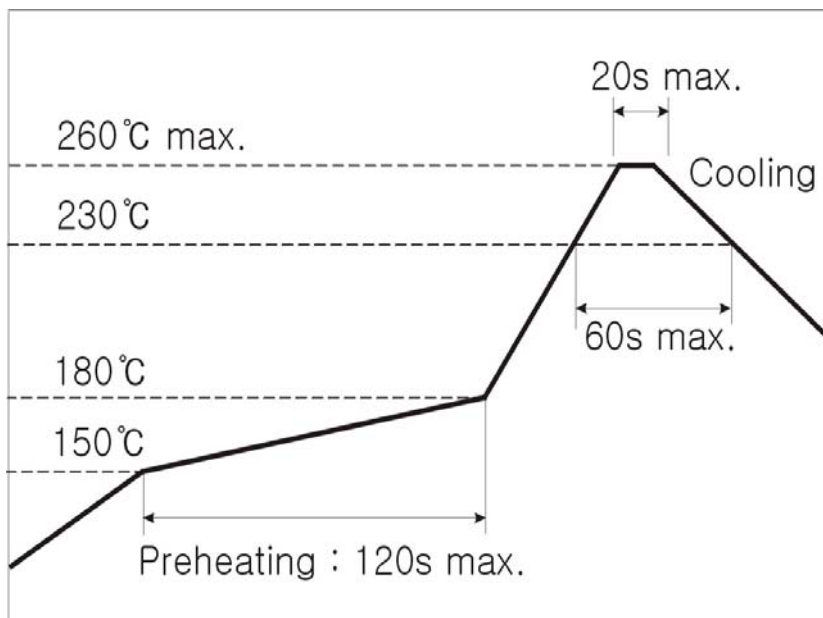

AVL 0603 Series Multilayer Chip Varistor



Overview

ESD Varistor is a component which acts as a non-conductor on the circuit in normal circumstances. When over-voltage is loaded, it becomes a conductor which diverts over-current from circuits to ground at critical voltage level.

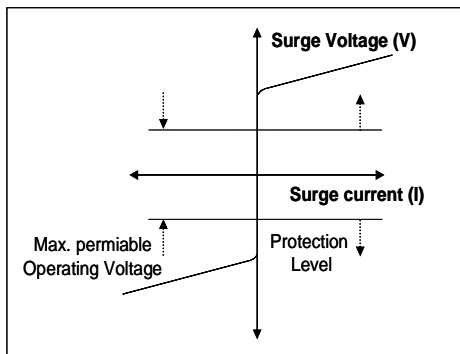

Fig 1 V-I Characteristic Curve

Features

- Meets IEC 61000-4-2 (ESD)
- Level 4 & IEC 61000-4-4 (EFT), Level 4 requirements
- ESD Protection > 25 KV
- Low capacitance for high frequency data line protection
- Fast response time < 1ns
- Available in tape and reel for automatic pick and place

Applications

- Mobile Phone & PDA
- Cellular Phone
- PCMCIA / Compact Flash Card
- RS-232 & RS-423 Data Lines
- USB Data Lines
- MCM Boards
- LCD Module

Model Description

<u>AVL</u>	<u>5</u>	<u>M</u>	<u>03</u>	<u>300</u>
(1)	(2)	(3)	(4)	(5)

- (1) Series name : "AVL" – General Type
- (2) Maximum continuous working voltage (Vdc) : "5"- 5.5V, "14"- 14V, "18"- 18V
- (3) Breakdown voltage tolerance : "S" - special order, M: 20 % Vn tolerance
- (4) Chip size : 02 - 0402(1.0x0.5mm), 03 - 0603(1.6x0.8mm)
- (5) Peak current : 300 - 30 A

AVL 0603 Series Multilayer Chip Varistor



Electrical characteristics

Part No.	Vdc ⁽¹⁾	Varistor voltage (Vn) @1mA DC	Leakage Current (IL) @Vdc	Cp (@ 1kHz, V _{rms} =0.5V)	Clamping Voltage (VC)	Peak Current (Imax)	Insulation Resistance (IR) @3.6V
	(V)	(V)	(μ A)	(pF)	(V)	(A)	(M Ω)
AVL5M03300	5.5	6.4-9.6	20 max	800(560-1040)	15	30	10 min
AVL14K03300	14	16.2-19.8	20 max	350(245-455)	35	30	10 min
AVL18S03 300 LC75	18	22-28	20 max	75(52.5-97.5)	40	30	10 min
AVL18S03 300 LC120	18	22-28	20 max	120(84-156)	40	30	10 min

(1) Maximum continuous DC working voltage

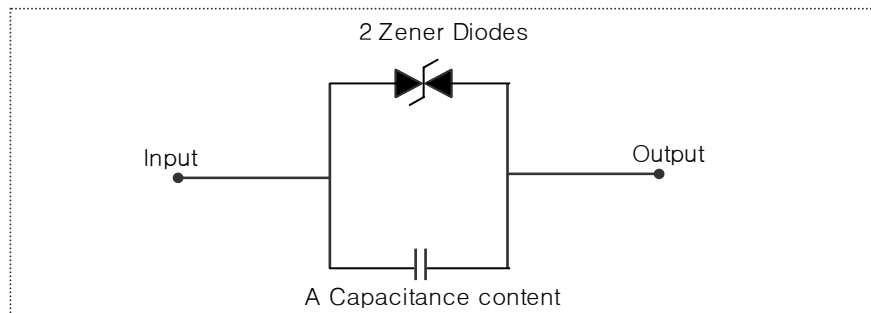
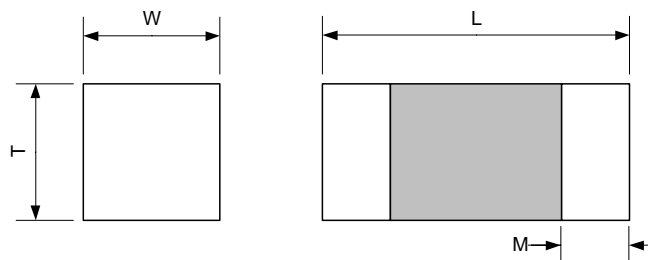

Fig.2 Equivalent Circuit

Appearance



Symbol	L	W	T	M
Size (mm)	1.6 ± 0.15	0.8 ± 0.15	Max. 0.9	0.35 ± 0.15

Recommended Land pattern (Typical Dimensions)

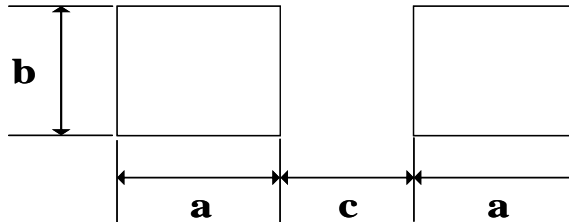

Symbol	a	b	c
Size (mm)	0.9	0.8	0.8

Recommended Soldering Profile

- Pb Free Solder Paste : Sn / Ag / Cu (96.5 / 3.0 / 0.5)

