

1 - Cathode  
2 - Anode  
Back of Case - Cathode

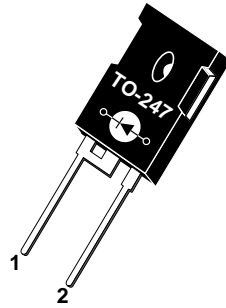

**ADVANCED  
POWER  
TECHNOLOGY®**  
**APT30D100B 1000V 30A**

## ULTRAFAST SOFT RECOVERY RECTIFIER DIODE

### PRODUCT APPLICATIONS

- Anti-Parallel Diode
  - Switchmode Power Supply
  - Inverters
- Free Wheeling Diode
  - Motor Controllers
  - Converters
- Snubber Diode
- Uninterruptible Power Supply (UPS)
- Induction Heating
- High Speed Rectifiers

### PRODUCT FEATURES

- Ultrafast Recovery Times
- Soft Recovery Characteristics
- Popular TO-247 Package
- Low Forward Voltage
- High Blocking Voltage
- Low Leakage Current

### PRODUCT BENEFITS

- Low Losses
- Low Noise Switching
- Cooler Operation
- Higher Reliability Systems
- Increased System Power Density

### MAXIMUM RATINGS

All Ratings:  $T_C = 25^\circ\text{C}$  unless otherwise specified.

Symbol	Characteristic / Test Conditions	APT30D100B	UNIT
$V_R$	Maximum D.C. Reverse Voltage	1000	Volts
$V_{RRM}$	Maximum Peak Repetitive Reverse Voltage		
$V_{RWM}$	Maximum Working Peak Reverse Voltage		
$I_F(AV)$	Maximum Average Forward Current ( $T_C = 85^\circ\text{C}$ , Duty Cycle = 0.5)	30	Amps
$I_F(RMS)$	RMS Forward Current	70	
$I_{FSM}$	Non-Repetitive Forward Surge Current ( $T_J = 45^\circ\text{C}$ , 8.3ms)	210	
$T_J, T_{STG}$	Operating and Storage Temperature Range	-55 to 150	$^\circ\text{C}$
$T_L$	Lead Temperature: 0.063" from Case for 10 Sec.	300	

### STATIC ELECTRICAL CHARACTERISTICS

Symbol	Characteristic / Test Conditions	MIN	TYP	MAX	UNIT
$V_F$	Maximum Forward Voltage			2.3	Volts
				$I_F = 30\text{A}$	
				$I_F = 60\text{A}$	
$I_{RM}$	Maximum Reverse Leakage Current			1.9	$\mu\text{A}$
				$I_F = 30\text{A}, T_J = 150^\circ\text{C}$	
				$V_R = V_R$ Rated	
$I_{RM}$				250	$\mu\text{A}$
				$V_R = V_R$ Rated, $T_J = 125^\circ\text{C}$	
$C_T$	Junction Capacitance, $V_R = 200\text{V}$		30		pF
$L_S$	Series Inductance (Lead to Lead 5mm from Base)		10		nH

#### USA

405 S.W. Columbia Street

#### EUROPE

Avenue J.F. Kennedy Bât B4 Parc Cadéra Nord

APT Website - <http://www.advancedpower.com>

Bend, Oregon 97702-1035

F-33700 Merignac - France

Phone: (541) 382-8028

Phone: (33) 5 57 92 15 15

FAX: (541) 388-0364

FAX: (33) 5 56 47 97 61

### DYNAMIC CHARACTERISTICS

APT30D100B

Symbol	Characteristic	MIN	TYP	MAX	UNIT
$t_{rr1}$	Reverse Recovery Time, $I_F = 1.0A$ , $di_F/dt = -15A/\mu s$ , $V_R = 30V$ , $T_J = 25^\circ C$		60	75	ns
$t_{rr2}$	Reverse Recovery Time		60		
$t_{rr3}$	$I_F = 30A$ , $di_F/dt = -240A/\mu s$ , $V_R = 540V$		120		
$t_{fr1}$	Forward Recovery Time		165		
$t_{fr2}$	$I_F = 30A$ , $di_F/dt = 240A/\mu s$ , $V_R = 540V$		165		
$I_{RRM1}$	Reverse Recovery Current		6	13	Amps
$I_{RRM2}$	$I_F = 30A$ , $di_F/dt = -240A/\mu s$ , $V_R = 540V$		10	18	
$Q_{rr1}$	Recovery Charge		180		nC
$Q_{rr2}$	$I_F = 30A$ , $di_F/dt = -240A/\mu s$ , $V_R = 540V$		600		
$V_{fr1}$	Forward Recovery Voltage		8.4		Volts
$V_{fr2}$	$I_F = 30A$ , $di_F/dt = 240A/\mu s$ , $V_R = 540V$		8.4		
$diM/dt$	Rate of Fall of Recovery Current		450		A/ $\mu s$
	$I_F = 30A$ , $di_F/dt = -240A/\mu s$ , $V_R = 540V$ (See Figure 10)		250		

### THERMAL AND MECHANICAL CHARACTERISTICS

Symbol	Characteristic / Test Conditions	MIN	TYP	MAX	UNIT
$R_{\theta JC}$	Junction-to-Case Thermal Resistance			0.90	$^\circ C/W$
$R_{\theta JA}$	Junction-to-Ambient Thermal Resistance			40	
$W_T$	Package Weight		0.22		oz
			6.1		gm
Torque	Maximum Mounting Torque (Screw Type = 6-32 or 3mm Machine)			10	lb•in
				1.1	N•m

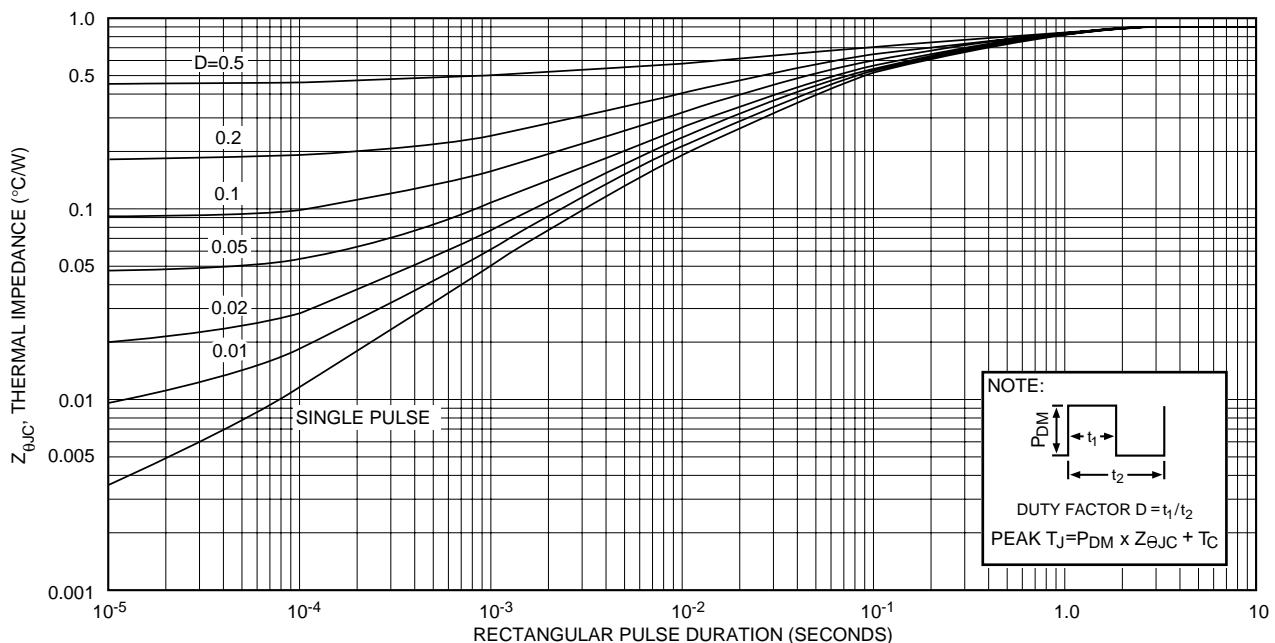
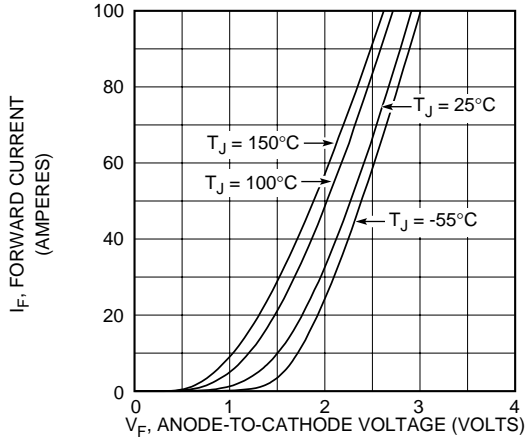
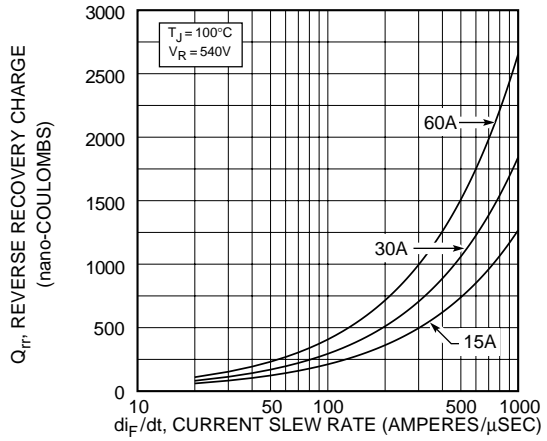

FIGURE 1, MAXIMUM EFFECTIVE TRANSIENT THERMAL IMPEDANCE, JUNCTION-TO-CASE vs PULSE DURATION

**APT30D100B**



**Figure 2, Forward Voltage Drop vs Forward Current**



**Figure 3, Reverse Recovery Charge vs Current Slew Rate**

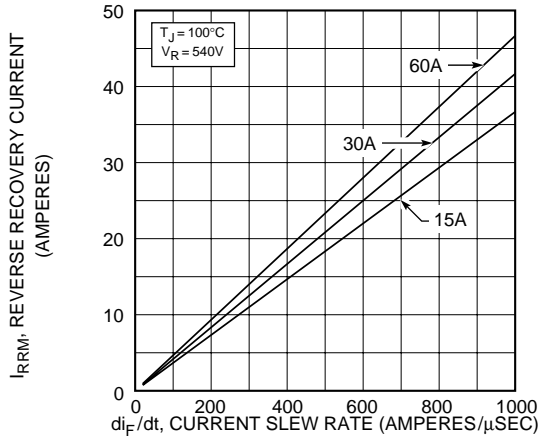

**Figure 4, Reverse Recovery Current vs Current Slew Rate**

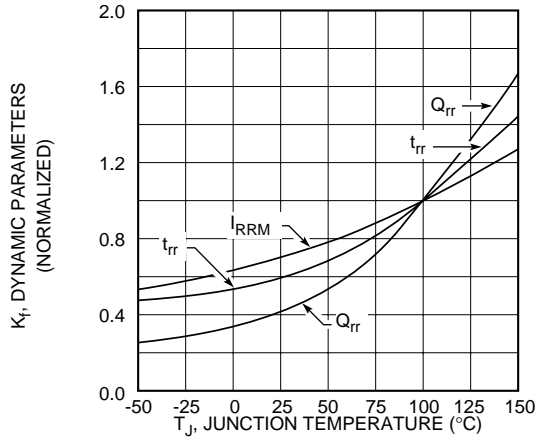

**Figure 5, Dynamic Parameters vs Junction Temperature**

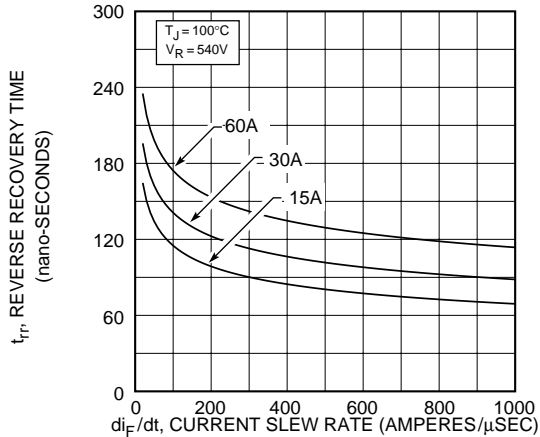

**Figure 6, Reverse Recovery Time vs Current Slew Rate**

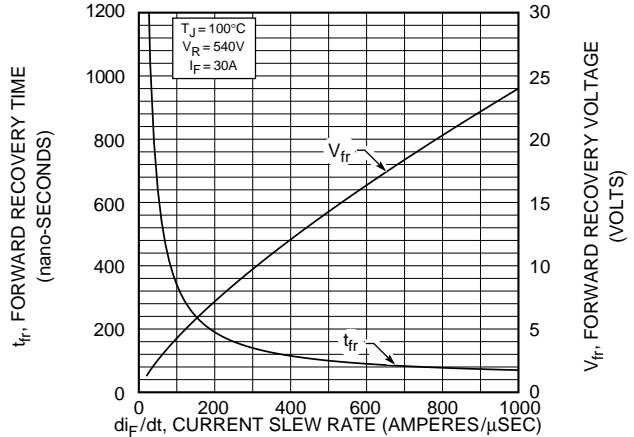

**Figure 7, Forward Recovery Voltage/Time vs Current Slew Rate**

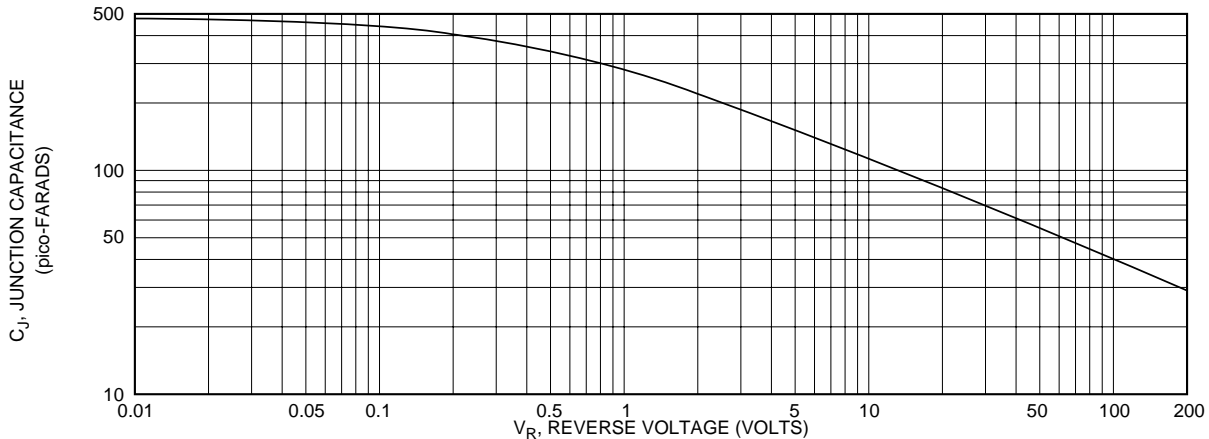

**Figure 8, Junction Capacitance vs Reverse Voltage**

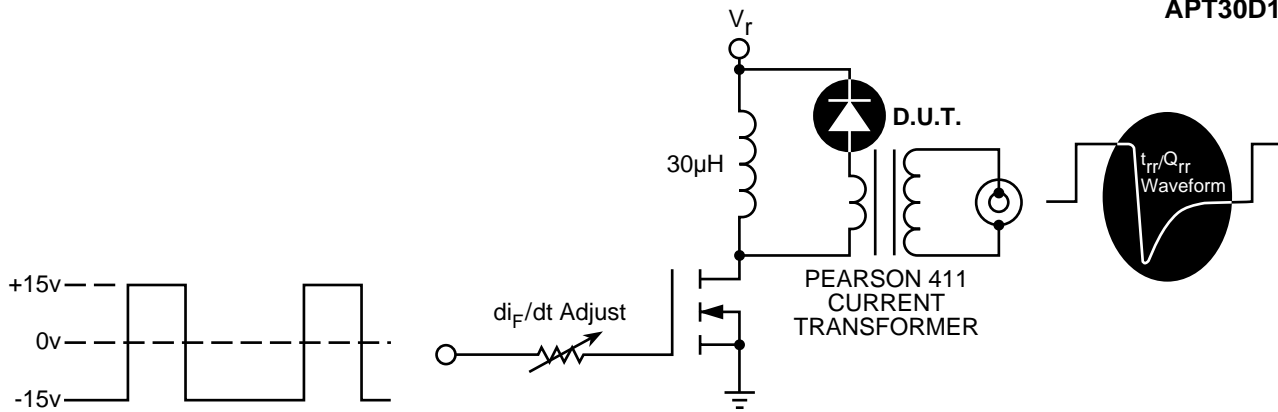

Figure 9, Diode Reverse Recovery Test Circuit and Waveforms

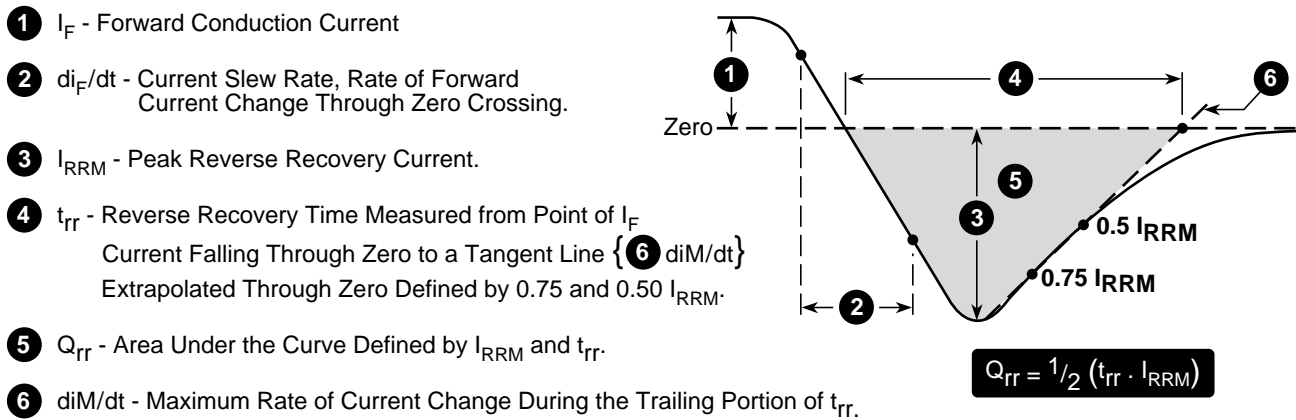
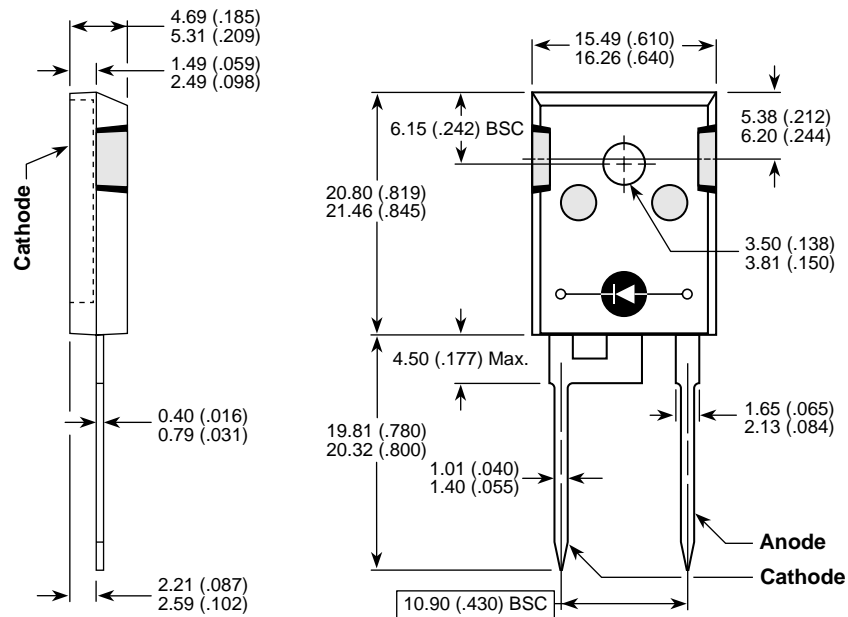

Figure 10, Diode Reverse Recovery Waveform and Definitions

### TO-247 Package Outline



Dimensions in Millimeters and (Inches)

This datasheet has been download from:

[www.datasheetcatalog.com](http://www.datasheetcatalog.com)

Datasheets for electronics components.