

## Zener Diodes

### Features

- High reliability
- Voltage range 10 V to 270 V
- Fits onto 5 mm SMD footpads
- Wave and reflow solderable
- AEC-Q101 qualified
- Compliant to RoHS directive 2002/95/EC and in accordance to WEEE 2002/96/EC



**RoHS**  
COMPLIANT

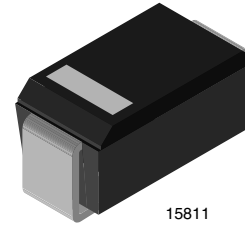

### Applications

- Voltage stabilization

### Mechanical Data

**Case:** DO-214AC

**Weight:** approx. 77 mg

**Packaging codes/options:**

TR/1.5K 7" reel

TR3/6K 13" reel 6K/box

### Absolute Maximum Ratings

$T_{amb} = 25\text{ }^{\circ}\text{C}$ , unless otherwise specified

Parameter	Test condition	Symbol	Value	Unit
Power dissipation	$R_{thJA} < 25\text{ K/W}$ , $T_{amb} = 100\text{ }^{\circ}\text{C}$	$P_{diss}$	3	W
	$R_{thJA} < 100\text{ K/W}$ , $T_{amb} = 50\text{ }^{\circ}\text{C}$	$P_{diss}$	1.25	W
Non repetitive peak surge power dissipation	$t_p = 100\text{ }\mu\text{s sq.pulse}$ , $T_j = 25\text{ }^{\circ}\text{C}$ prior to surge	$P_{ZSM}$	600	W
Junction temperature		$T_j$	150	$^{\circ}\text{C}$
Storage temperature range		$T_{stg}$	- 65 to + 150	$^{\circ}\text{C}$

### Thermal Characteristics

$T_{amb} = 25\text{ }^{\circ}\text{C}$ , unless otherwise specified

Parameter	Test condition	Symbol	Value	Unit
Junction lead		$R_{thJL}$	25	K/W
Junction ambient	Mounted on epoxy-glass hard tissue, fig. 1a	$R_{thJA}$	150	K/W
	Mounted on epoxy-glass hard tissue, fig. 1b	$R_{thJA}$	125	K/W
	Mounted on Al-oxid-ceramic ( $\text{Al}_2\text{O}_3$ ), fig. 1b	$R_{thJA}$	100	K/W

### Electrical Characteristics

$T_{amb} = 25\text{ }^{\circ}\text{C}$ , unless otherwise specified

Parameter	Test condition	Symbol	Min.	Typ.	Max.	Unit
Forward voltage	$I_F = 0.5\text{ A}$	$V_F$			1.2	V

## Electrical Characteristics

BZG03C...

Part number	Zener voltage range			Dynamic resistance		Test current	Temperature coefficient of zener voltage		Reverse leakage current	
	$V_Z$ at $I_{ZT}$			$r_{zj}$ and $TK_{VZ}$ at $I_{ZT}$		$I_{ZT}$	$TK_{VZ}$ at $I_{ZT}$		$I_R$ at $V_R$	
	V			$\Omega$		mA	%K		$\mu A$	V
	min.	typ.	max.	typ.	max.		min.	max.	max.	
BZG03C10	9.4	10	10.6	2	4	50	0.05	0.09	10	7.5
BZG03C11	10.4	11	11.6	4	7	50	0.05	0.1	4	8.2
BZG03C12	11.4	12	12.7	4	7	50	0.05	0.1	3	9.1
BZG03C13	12.4	13	14.1	5	10	50	0.05	0.1	2	10
BZG03C15	13.8	15	15.6	5	10	50	0.05	0.1	1	11
BZG03C16	15.3	16	17.1	6	15	25	0.06	0.11	1	12
BZG03C18	16.8	18	19.1	6	15	25	0.06	0.11	1	13
BZG03C20	18.8	20	21.2	6	15	25	0.06	0.11	1	15
BZG03C22	20.8	22	23.3	6	15	25	0.06	0.11	1	16
BZG03C24	22.8	24	25.6	7	15	25	0.06	0.11	1	18
BZG03C27	25.1	27	28.9	7	15	25	0.06	0.11	1	20
BZG03C30	28	30	32	8	15	25	0.06	0.11	1	22
BZG03C33	31	33	35	8	15	25	0.06	0.11	1	24
BZG03C36	34	36	38	21	40	10	0.06	0.11	1	27
BZG03C39	37	39	41	21	40	10	0.06	0.11	1	30
BZG03C43	40	43	46	24	45	10	0.07	0.12	1	33
BZG03C47	44	47	50	24	45	10	0.07	0.12	1	36
BZG03C51	48	51	54	25	60	10	0.07	0.12	1	39
BZG03C56	52	56	60	25	60	10	0.07	0.12	1	43
BZG03C62	58	62	66	25	80	10	0.08	0.13	1	47
BZG03C68	64	68	72	25	80	10	0.08	0.13	1	51
BZG03C75	70	75	79	30	100	10	0.08	0.13	1	56
BZG03C82	77	82	87	30	100	10	0.08	0.13	1	62
BZG03C91	85	91	96	60	200	5	0.09	0.13	1	68
BZG03C100	94	100	106	60	200	5	0.09	0.13	1	75
BZG03C110	104	110	116	80	250	5	0.09	0.13	1	82
BZG03C120	114	120	127	80	250	5	0.09	0.13	1	91
BZG03C130	124	130	141	110	300	5	0.09	0.13	1	100
BZG03C150	138	150	156	130	300	5	0.09	0.13	1	110
BZG03C160	158	160	171	150	350	5	0.09	0.13	1	120
BZG03C180	168	180	191	180	400	5	0.09	0.13	1	130
BZG03C200	188	200	212	200	500	5	0.09	0.13	1	150
BZG03C220	208	220	233	350	750	2	0.09	0.13	1	160
BZG03C240	228	240	256	400	850	2	0.09	0.13	1	180
BZG03C270	251	270	289	450	1000	2	0.09	0.13	1	200

## Typical Characteristics

$T_{amb} = 25\text{ }^{\circ}\text{C}$ , unless otherwise specified

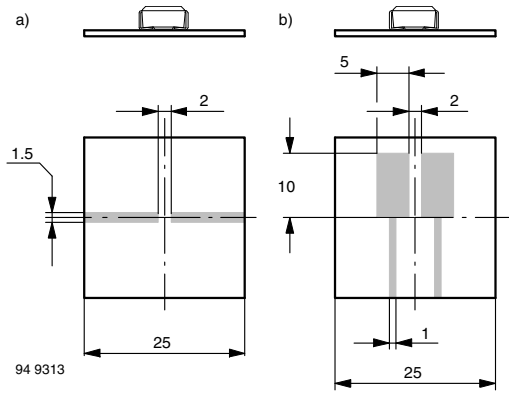

Figure 1. Boards for  $R_{thJA}$  Definition (Copper Overlay  $35\text{ }\mu$ )

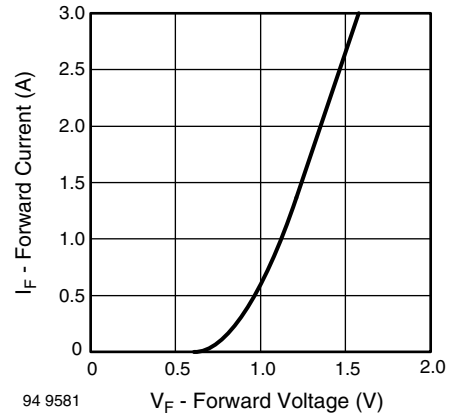

Figure 3. Forward Current vs. Forward Voltage

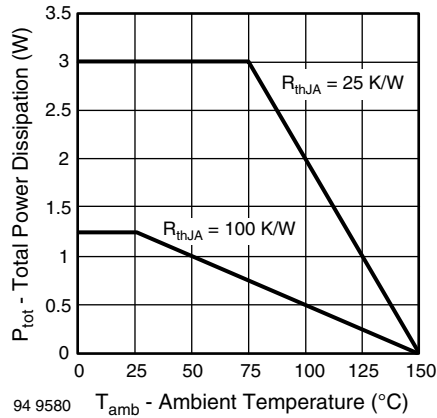

Figure 2. Total Power Dissipation vs. Ambient Temperature

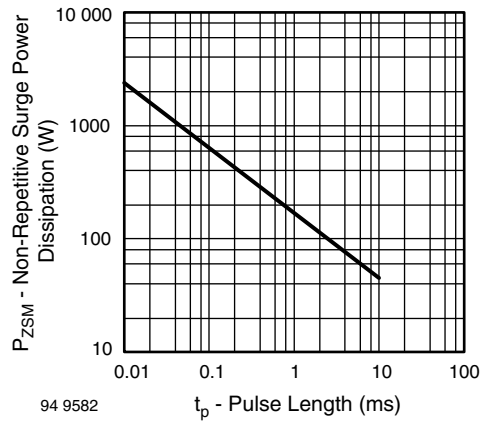

Figure 4. Non Repetitive Surge Power Dissipation vs. Pulse Length

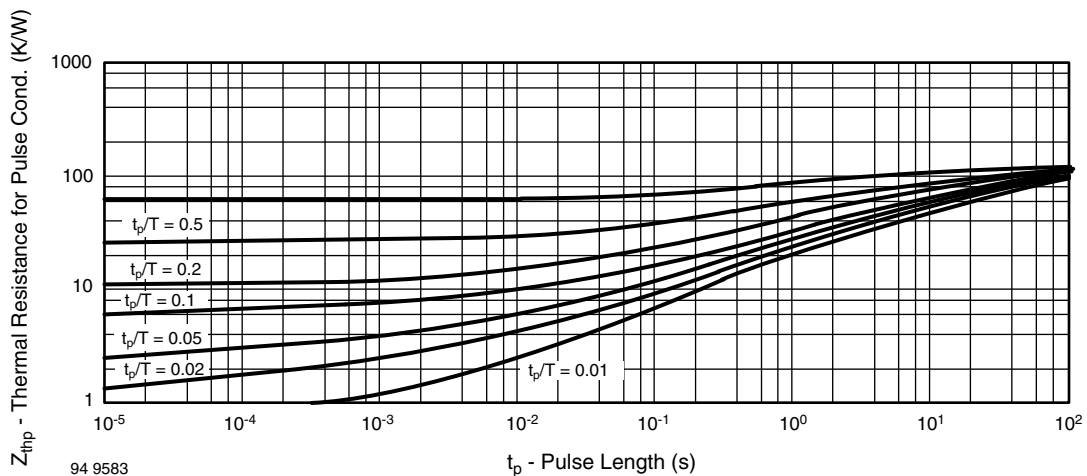

Figure 5. Thermal Response

# BZG03C-Series



Vishay Semiconductors

Package Dimensions in millimeters (inches): **DO-214AC**

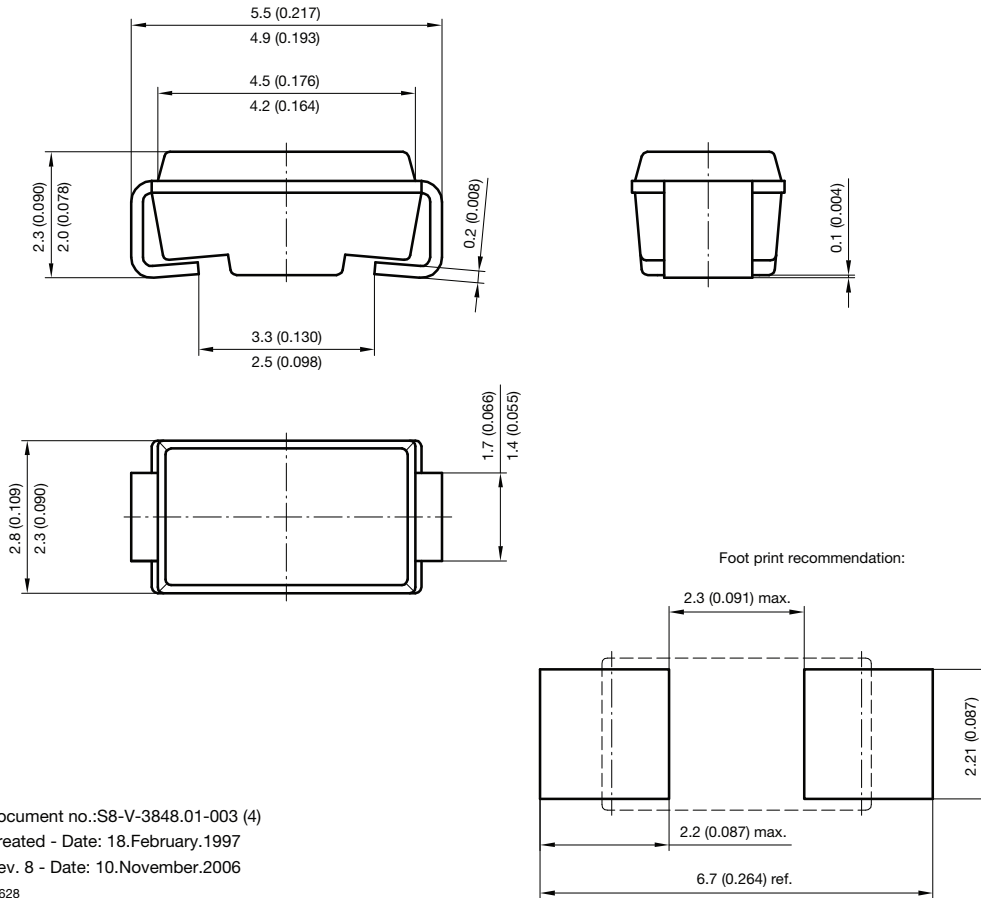

Document no.:S8-V-3848.01-003 (4)  
Created - Date: 18.February.1997  
Rev. 8 - Date: 10.November.2006  
19628



## Disclaimer

ALL PRODUCT, PRODUCT SPECIFICATIONS AND DATA ARE SUBJECT TO CHANGE WITHOUT NOTICE TO IMPROVE RELIABILITY, FUNCTION OR DESIGN OR OTHERWISE.

Vishay Intertechnology, Inc., its affiliates, agents, and employees, and all persons acting on its or their behalf (collectively, "Vishay"), disclaim any and all liability for any errors, inaccuracies or incompleteness contained in any datasheet or in any other disclosure relating to any product.

Vishay makes no warranty, representation or guarantee regarding the suitability of the products for any particular purpose or the continuing production of any product. To the maximum extent permitted by applicable law, Vishay disclaims (i) any and all liability arising out of the application or use of any product, (ii) any and all liability, including without limitation special, consequential or incidental damages, and (iii) any and all implied warranties, including warranties of fitness for particular purpose, non-infringement and merchantability.

Statements regarding the suitability of products for certain types of applications are based on Vishay's knowledge of typical requirements that are often placed on Vishay products in generic applications. Such statements are not binding statements about the suitability of products for a particular application. It is the customer's responsibility to validate that a particular product with the properties described in the product specification is suitable for use in a particular application. Parameters provided in datasheets and/or specifications may vary in different applications and performance may vary over time. All operating parameters, including typical parameters, must be validated for each customer application by the customer's technical experts. Product specifications do not expand or otherwise modify Vishay's terms and conditions of purchase, including but not limited to the warranty expressed therein.

Except as expressly indicated in writing, Vishay products are not designed for use in medical, life-saving, or life-sustaining applications or for any other application in which the failure of the Vishay product could result in personal injury or death. Customers using or selling Vishay products not expressly indicated for use in such applications do so at their own risk and agree to fully indemnify and hold Vishay and its distributors harmless from and against any and all claims, liabilities, expenses and damages arising or resulting in connection with such use or sale, including attorneys fees, even if such claim alleges that Vishay or its distributor was negligent regarding the design or manufacture of the part. Please contact authorized Vishay personnel to obtain written terms and conditions regarding products designed for such applications.

No license, express or implied, by estoppel or otherwise, to any intellectual property rights is granted by this document or by any conduct of Vishay. Product names and markings noted herein may be trademarks of their respective owners.