

# 工业级电机正反转控制模块

## Motor Controllers

### Industrial, 2-Phase IO Reversing

#### Types RR2 I .... HAP, RR2 I .... LAP, RR2 I .... HDP



- 适用于功率高达3KW三相感应马达正反转控制固态继电器。  
(Motor reversing Solid State Relays for 3-phase induction motors up to 3 kW)
- 额定工作电压高达480VACrms (Rated operational voltage: Up to 480 VACrms)
- 内置互锁电路功能 (Built-in interlock function)
- 交流和直流电压控制 (AC or DC control voltage)
- 内置瞬间突波保护功能 (Built-in voltage transient protection)
- LED状态指示 (LED indication for direction)
- 隔离电压高达4000VACrms(输入-输出间)  
(Insulation: Reed relay or optocoupler (input-output) 4000 VACrms)
- 铜瓷键合封装工艺, 高可靠性 (Direct copper bonding technology)



### 产品描述 (Product Description)

电机正反转控制固态继电器系列是依照设计为最大功率为3KW三相感应电机切换正反转状态的。内置互锁电路, 是为了交流和直流控制时不在同一时间切换, 双色LED发光二极管分别指示运转方向。内置压敏电阻保护回路, 防止极度的瞬变突波电压发生而损坏继电器。直接的裸片封装在铜瓷键合基板工艺, 热阻低, 可靠性极高。

推荐使用温度限制开关安装在产品周围防止温升过高, 及安装半导体级快速熔断器串联在线路中防止过电流及短路现象发生而损坏继电器。

### 定货索引 (Ordering Key)

**RR2I4015HDP**

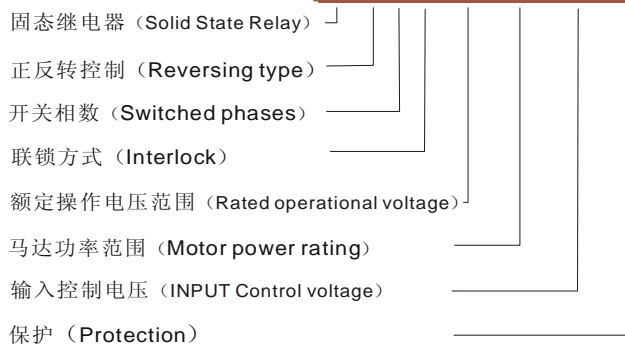

This family of motor reversing Solid State Relays is designed to switch 3-phase motors rated up to 3 kW. The built-in interlocking circuitry for both AC and DC control voltage prevents the relay from switching both directions at the same time. A dual colour LED indicates direction "forward" when green and direction "reverse" when red. The output alternistor chips are protected from excessive voltage fluctuations (transients) by the built-in varistors. Furthermore, optimum reliability is achieved by soldering the output alternistor chips directly on to the ceramic substrate (Direct Copper Bonding).

The housing is designed to incorporate a temperature limit switch. It is recommended to install an appropriate semiconductor fuse in series with the relay.

### 型号选择 (Type Selection)

开关方式 Switching mode	互锁功能 Interlocking	额定操作电压 Rated operational voltage	通断功率 Load power	控制电压 Control voltage	保护 Protection
RR2: Reversing relay (2-phase) (2相) 控制正反转继电器	I: Interlock 互锁功能	40: 400 VACrms 48: 480 VACrms	05: 0.5 kW 15: 1.5 kW 30: 3.0 kW	HD: 10 - 40 VDC LA: 90 - 140 VAC HA: 180 - 265 VAC	P: Protected (varistor) 压敏电阻器保护

### 选型指南 (Selection Guide)

额定操作电压 Rated operational voltage	控制电压 Control voltage	通断功率 Load power		
		0.5 kW	1.5 kW	3.0 kW
400 VACrms	10 to 40 VDC	RR2 I 4005 HDP	RR2 I 4015 HDP	RR2 I 4030 HDP
	90 to 140 VAC	RR2 I 4005 LAP	RR2 I 4015 LAP	RR2 I 4030 LAP
	180 to 265 VAC	RR2 I 4005 HAP	RR2 I 4015 HAP	RR2 I 4030 HAP
480 VACrms	10 to 40 VDC	RR2 I 4805 HDP	RR2 I 4815 HDP	RR2 I 4830 HDP
	90 to 140 VAC	RR2 I 4805 LAP	RR2 I 4815 LAP	RR2 I 4830 LAP
	180 to 265 VAC	RR2 I 4805 HAP	RR2 I 4815 HAP	RR2 I 4830 HAP

乐清市立得电子有限公司  
YUEQING LIDE ELECTRONICS CO., LTD

Abb: Dongan Zone LiuJing Road Liushi Yueqing Zhejiang  
(Tel): 86 577 62736616 (Fax): 86 577 62736617  
Http://www.ldgcn.com E-mail: ldgcn1@hotmail.com

## 常规参数 (General Specifications)

	RR2 I 40...P	RR2 I 48...P
操作的电压范围Operational voltage range	120 to 440 VACrms	120 to 530 VACrms
非重复 峰值电压Non-rep. peak voltage	$\geq 1200 V_p$	$\geq 1400 V_p$
操作的频率范围Operational frequency range	45 to 65 Hz	45 to 65 Hz
功率因素Power factor	$\geq 0.5 @ 400 VACrms$	$\geq 0.5 @ 480 VACrms$

## 输入规格 (Input Specifications)

	RR2 I .... HDP	RR2 I .... LAP	RR2 I .... HAP
控制电压 (Control voltage)	10 to 40 VDC	90 to 140 VAC	180 to 265 VAC
起始电压 (Pick-up voltage)	$\leq 10 VDC$	$\leq 90 VAC$	$\leq 180 VAC$
脱离电压 (Drop out voltage)	$\geq 3 VDC$	$\geq 30 VAC$	$\geq 60 VAC$
电力消耗 (Power consumption)	$\leq 1.4 W$	$\leq 4 VA$	$\leq 4 VA$
时间延迟 (Time delay) F → R, R → F	$\leq 50 ms$	$\leq 100 ms$	$\leq 100 ms$

## 输出规格 (Output Specifications)

	RR2 I 4005 ..P RR2 I 4805 ..P	RR2 I 4015 ..P RR2 I 4815 ..P	RR2 I 4030 ..P RR2 I 4830 ..P
额定的操作电流 AC51 (Rated operational current) AC53a	2 × 10 AACrms 2 × 1.5 AACrms	2 × 25 AACrms 2 × 3.5 AACrms	2 × 40 AACrms 2 × 6 AACrms
最少的操作的电流 (Min. operational current)	200 mA	200 mA	200 mA
过电流 t=1s(Rep. overload current t=1 s)	< 12 AACrms	< 37 AACrms	< 60 AACrms
非重复冲击电流 (Non-rep. surge current t=10 ms)	100 Ap	300 Ap	390 Ap
断态泄露电流 @ 对电压和频率估计 (Off-state leakage current @ rated voltage and frequency)	$\leq 10mA$	$\leq 10mA$	$\leq 10mA$
I2t for fusing t=1-10 ms	$\leq 72 A^2s$	$\leq 450 A^2s$	$\leq 760 A^2s$
临界的di/dt (Critical di/dt)	$\geq 10 A/\mu s$	$\geq 50 A/\mu s$	$\geq 50 A/\mu s$
通态电压降 (On-state voltage drop @ rated current)	$\leq 1.6 Vrms$	$\leq 1.6 Vrms$	$\leq 1.6 Vrms$
通态电压上升率 (Critical dV/dt off-state)	$\geq 500V/\mu s$	$\geq 500 V/\mu s$	$\geq 500 V/\mu s$

## 温度规格 (Thermal Specifications)

	RR2 I 4005 ..P RR2 I 4805 ..P	RR2 I 4015 ..P RR2 I 4815 ..P	RR2 I 4030 ..P RR2 I 4830 ..P
操作温度 (Operating temperature)	-20° to 70° C	-20° to 70° C	-20° to 70° C
储藏温度 (Storage temperature)	-40° to 100° C	-40° to 100° C	-40° to 100° C

  
**乐清市立得电子有限公司**  
**YUEQING LIDE ELECTRONICS CO.,LTD**

Abb: Dongan Zone LiuJing Road Liushi Yueqing Zhejiang  
 (Tel): 86 577 62736616 (Fax): 86 577 62736617  
 Http://www.ldgc.com E-mail: ldgc1@hotmail.com

**隔离 (Insulation)**

额定绝缘电压 (Rated insulation voltage) 输入-输出(Input to output) 输出-外壳(Input to case)	$\geq 4000$ VACrms $\geq 4000$ VACrms
额定绝缘电压 (Rated insulation voltage) 输出-外壳(Input to case)	$\geq 4000$ VACrms

**附件 (Accessories)**

散热器(Heatsinks)	For further information refer to "General Accessories".
保险丝(Fuses)	Temperature limit switch
温度限制开关	

**配线图 (Wiring Diagram)**

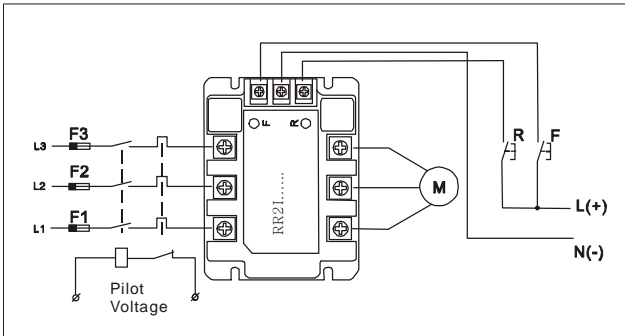

**功能图 (Functional Diagram)**

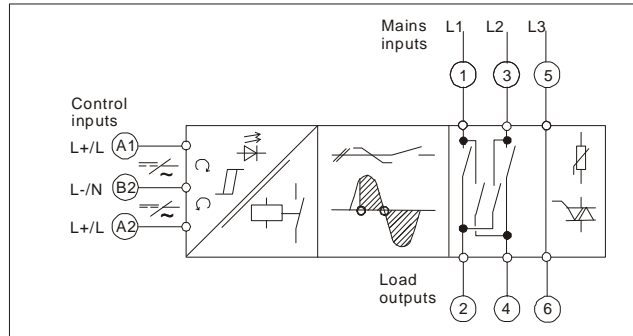

**散热器尺寸 (Heatsink Dimensions)**

Motor Relay Load	Type of heatsink (at max. 50 °C ambient temp.)
0.5 kW RR2 I..P	No heatsink required (mounted on backplate)
1.5 kW RR2 I 4.15 ..P	2.5 K/W
3.0 kW RR2 I 4.30 ..P	1.0 K/W

**保险丝选择指导 (Fuse Selection Guide)**

Relay	Fuse FERRAZ PROTISTOR
RR2 I 4005 ..P	660 g RB 10-10
RR2 I 4015 ..P	660 g RB 10-25
RR2 I 4030 ..P	6.621 CP URGB 14 x 51/40

**应用图 (Applications)**

交流 / 直流输入 正转 / 反转 / 停止  
(AC/DC input forward/reverse/stop)

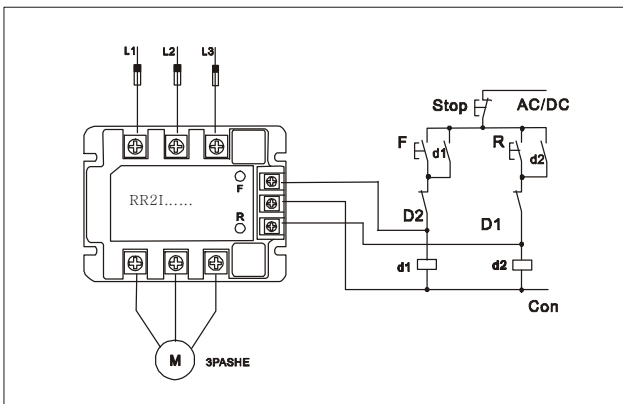

## 尺寸 (Dimensions)

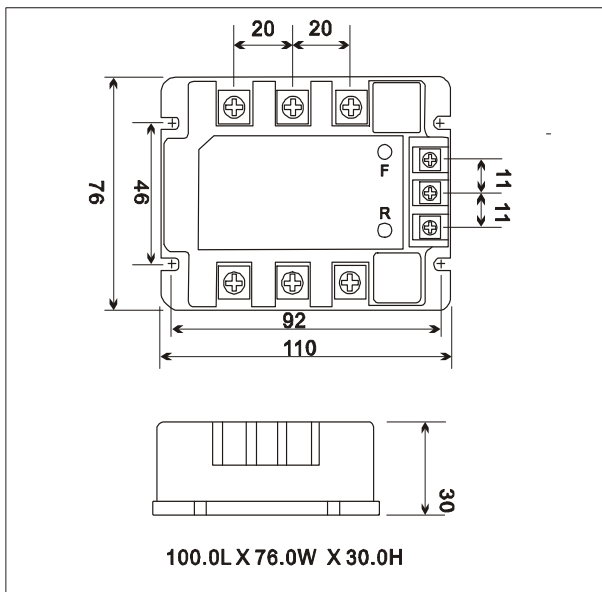

单位 mm(All dimensions in mm)

## 总体参数 (Housing Specifications)

重量(Weight)	约(Approx). 480 g
Housing material	Noryl, glass-reinforced
颜色(Colour)	深蓝色(Black)
Base plate	Aluminium, nickel-plated
Potting compound	Polyurethane, black
Relay	
Mounting screws	M4
Mounting torque	$\leq 1.5 \text{ Nm}$
Control terminal	
Mounting screws	M3
Mounting torque	$\leq 0.5 \text{ Nm}$
Wire size	Max. $2 \times 2.5 \text{ mm}^2$ (AWG 14)
	Min. $2 \times 1.0 \text{ mm}^2$
Power terminal	
Mounting screws	M4
Mounting torque	$\leq 2.5 \text{ Nm}$
Wire size	Max. $2 \times 6 \text{ mm}^2$ (AWG 8)
	Min. $2 \times 1 \text{ mm}^2$