

INFRARED RECEIVER MODULE

Description

The HL-1038H is miniaturized infrared receivers for remote control and other applications requiring improved ambient light rejection.

The separate PIN diode and preamplifier IC are assembled on a single leadframe.

The epoxy package contains a special IR filter.

This module has excellent performance even in disturbed ambient light applications and provides protection against uncontrolled output pulses.

Features

- Photo detector and preamplifier in one package .
- Internal filter for PCM frequency.
- Inner shield,good anti-interference ability.
- High immunity against ambient light.
- Improved shielding against electric field disturbance
- 3.0V or 5.0V supply voltage; low power consumption.
- TTL and CMOS compatibility.
- Suitable transmission code:NEC code,RC5 code.

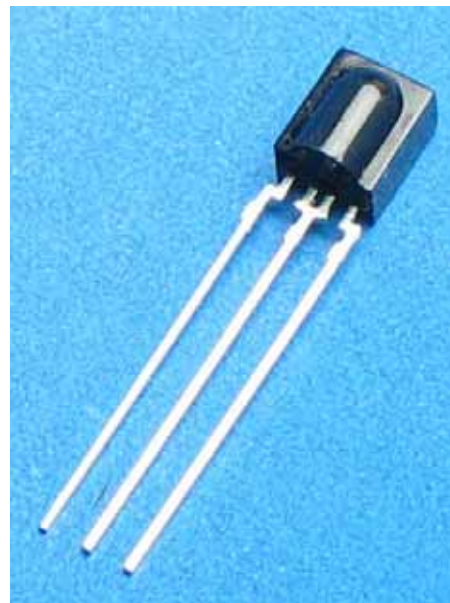

Applications:

1. Optical switch
2. Light detecting protion of remote contol
 - AV instruments such as Audio,TV,VCR,CD,MD,DVD,etc.
 - Home appliances such as Air-conditioner,Fan,etc.
 - CATV set top boxes
 - Multi-media Equipment

● Absolute Maximum Ratings(Ta=25)

Parameter	Symbol	Ratings	Unit	Notice
Supply Voltage	Vs	2.7-5.5	V	—
Operating Temperature	Topr	-20~+65		—
Storage Temperature	Tstg	-40~+85		—
Soldering Temperature	Tsd	260		4mm from mold body less than 5 sec

● **Electrical And Optical Characteristics**($T_a=25$)

Parameter	Symbol	Ratings			Unit	Condition
		Min.	Typ.	Max.		
Supply Voltage	V_s	2.4	-	5.5	V	
Supply Current	I_{cc}	—	—	1.5	mA	No signal input
Reception Distance	L_0	16	—	—	m	At the ray axis* 1
	L_{45}	8	—	—		
B.P.F Center Frequency	f_o	—	38	—	KHz	
Peak Wavelength	λ_p	—	940	—	nm	
Half Angle	θ	—	45	—	deg	At the ray axis * 1
High Level Pulse Width	T_H	400	—	800	μS	At the ray axis * 2
Low Level Pulse Width	T_L	400	—	800	μS	
High Level Output Voltage	V_H	4.5	—	—	V	
Low Level Output Voltage	V_L	—	—	0.5	V	

* 1: The ray receiving surface at a vertex and relation to the ray axis in the range of $\theta=0^\circ$ and $\theta=45^\circ$

* 2: A range from 30cm to the arrival distance. Average value of 50 pulses

BLOCK DIAGRAM

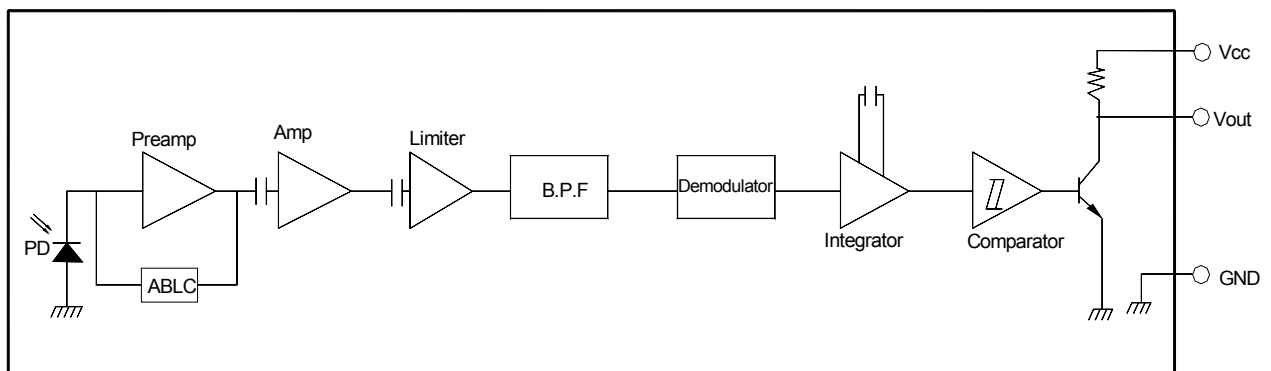

● Test Method

A. Standard Transmitter

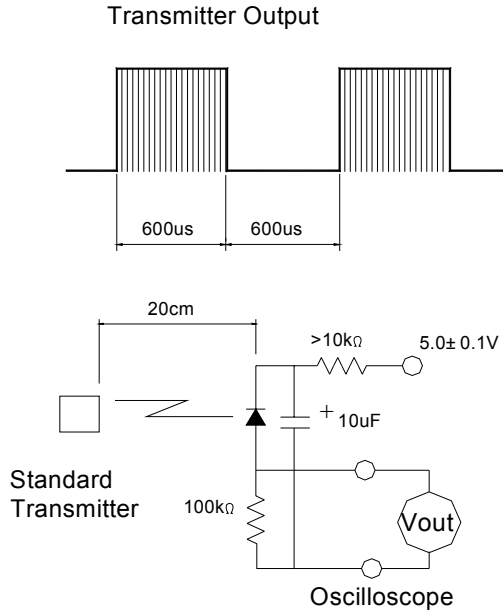

B. Detection Length Test

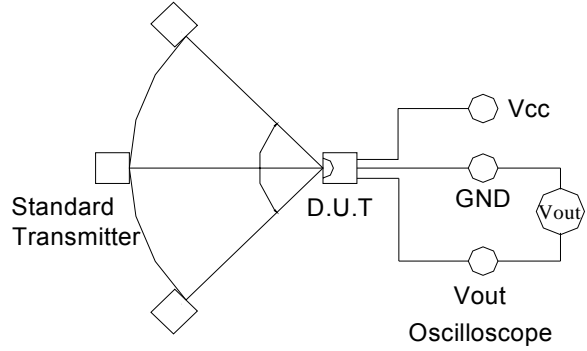

C. Pulse Width Test

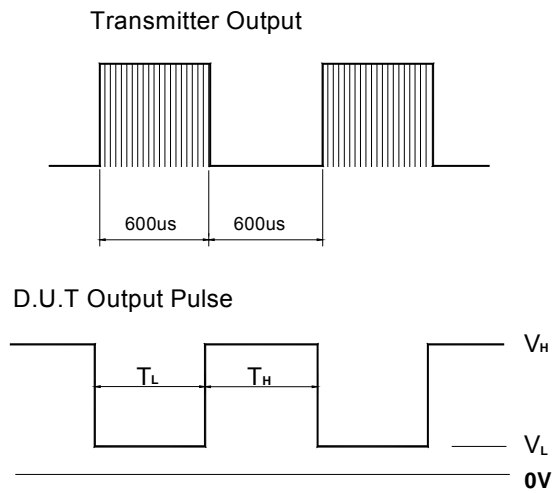

● Application Circuit

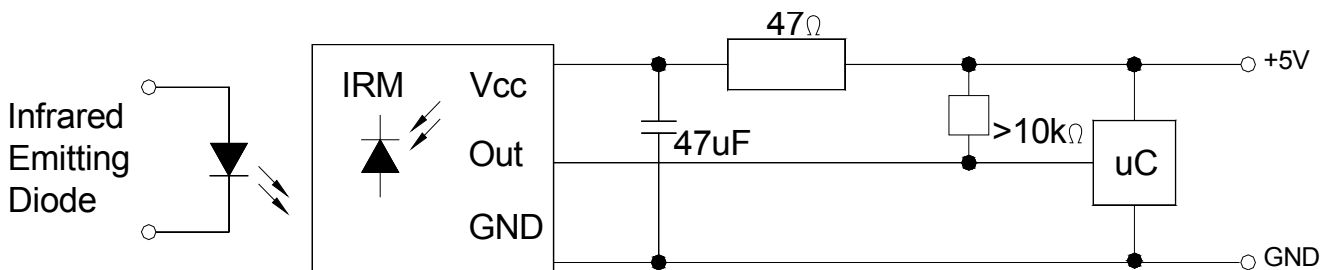

Package Dimensions:

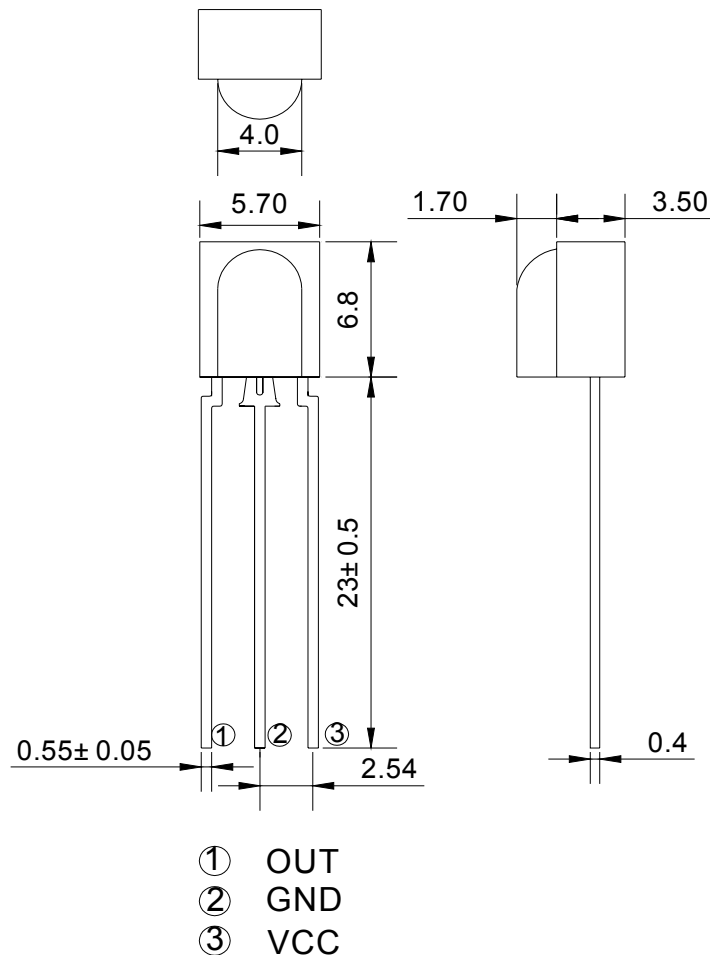

NOTES:

- 1.All dimensions are in millimeters (inches).
- 2.Tolerance is $\pm 0.30\text{mm}$ (0.012") unless otherwise specified.
- 3.Specifications are subject to change without notice.

● Electrical And Optical Curves(Ta=25)

