

Programmable Precision Reference

TL431

FEATURES

- Programmable Output Voltage to 40V
- Low Dynamic Output Impedance 0.2Ω
- Sink Current Capability of 0.1 mA to 100 mA
- Equivalent Full-Range Temperature Coefficient of 50 ppm/°C
- Temperature Compensated for Operation over Full Rated Operating Temperature Range
- Low Output Noise Voltage
- Fast Turn on Response
- TO-92, SOP- 8, SOT-23, SOT-89 packages

PIN CONNECTIONS

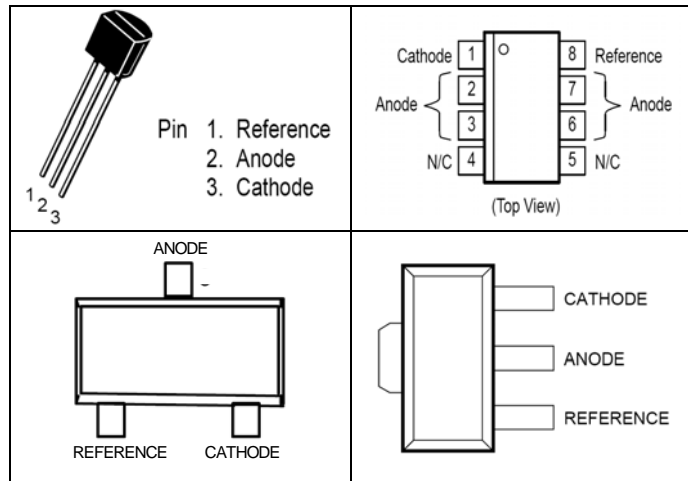

DESCRIPTION

The TL431 is a three-terminal adjustable regulator series with a guaranteed thermal stability over applicable temperature ranges. The output voltage may be set to any value between V_{ref} (approximately 2.5 volts) and 40 volts with two external resistors. These devices have a typical dynamic output impedance of 0.2Ω . Active output circuitry provides a very sharp turn-on characteristic, making these devices excellent replacement for zener diodes in many applications. The TL431 is characterized for operation from -25°C to $+85^\circ\text{C}$.

SYMBOL

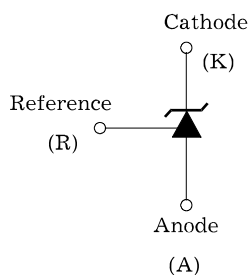

FUNCTIONAL BLOCK DIAGRAM

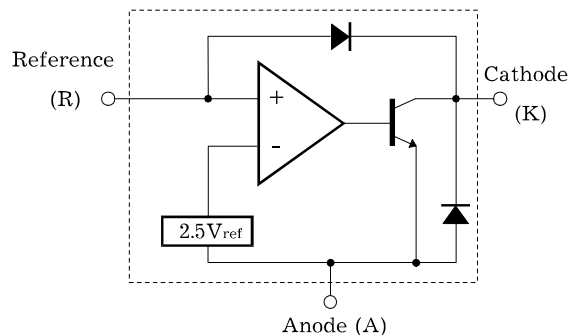

ABSOLUTE MAXIMUM RATINGS

(Operating temperature range applies unless otherwise specified)

Characteristic	Symbol	Value	Unit
Cathode Voltage	V_{KA}	40	V
Cathode Current Range (Continuous)	I_K	-100 ~ 150	mA
Reference Input Current Range	I_{REF}	0.05 ~ 10	mA
Power Dissipation at 25°C: SOP, TO – 92 Package ($R_{\theta JA} = 178^\circ\text{C/W}$) SOT Package ($R_{\theta JA} = 625^\circ\text{C/W}$)	P_D	0.7 0.2	W
Junction Temperature Range	T_J	-40 ~ 150	°C
Operating Temperature Range	T_g	-40 ~ +85	°C
Storage Temperature Range	T_{stg}	-65 ~ +150	°C

RECOMMENDED OPERATING CONDITIONS

Characteristic	Symbol	Test Condition	Min	Typ	Max	Unit
Cathode Voltage	V_{KA}		V_{REF}		40	V
Cathode Current	I_K		0.5		100	mA

ELECTRICAL CHARACTERISTICS

($T_a = 25^\circ\text{C}$, $V_{KA} = V_{REF}$, $I_K = 10\text{mA}$ unless otherwise specified)

Characteristic	Symbol	Test Condition	Min	Typ	Max	Unit
Reference Input Voltage	V_{REF}	$V_{KA} = V_{REF}$, $I_K = 10\text{mA}$ TL431 (2%) TL431-A (1%) TL431-C (0.5%)	2.440 2.470 2.482	2.495 2.495 2.495	2.550 2.520 2.508	V
Deviation of Reference Input Voltage Over Full Temperature Range	$V_{REF(dev)}$	$T_{min} \leq T_a \leq T_{max}$		3	17	MV
Ratio of Change in Reference Input Voltage to the Change in Cathode Voltage	$\frac{\Delta V_{REF}}{\Delta V_{KA}}$	$\Delta V_{KA} = 10\text{V} - V_{REF}$ $\Delta V_{KA} = 36\text{V} - 10\text{V}$		-1.4 -1.0	-2.7 -2.0	mV/V
Reference Input Current	I_{REF}	$R_1 = 10\text{K}\Omega$, $R_2 = \infty$		1.8	4	μA
Deviation of Reference Input Current Over Full Temperature Range	$I_{REF(dev)}$	$R_1 = 10\text{K}\Omega$, $R_2 = \infty$		0.4	1.2	μA
Minimum Cathode Current for Regulation	$I_{K(min)}$			0.25	0.5	mA
Off-State Cathode Current	$I_{K(off)}$	$V_{KA} = 40\text{V}$, $V_{REF} = 0$		0.26	0.9	μA
Dynamic Impedance	Z_{KA}	$I_K = 10\text{mA}$ to 100mA , $f \leq 1.0\text{KHz}$		0.22	0.5	Ω

TEST CIRCUITS

Figure 1. Test Circuit for $V_{KA} = V_{REF}$

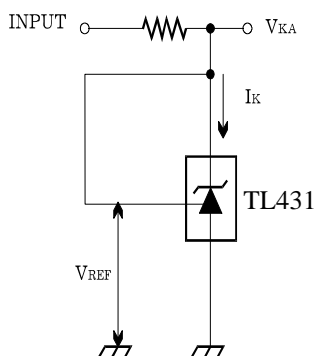

Figure 2. Test Circuit for $V_{KA} \geq V_{REF}$

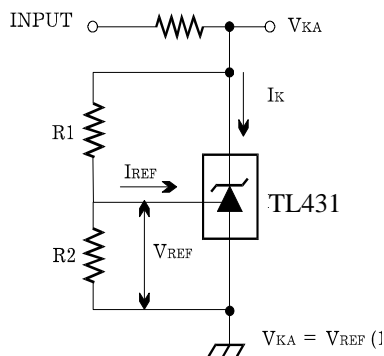
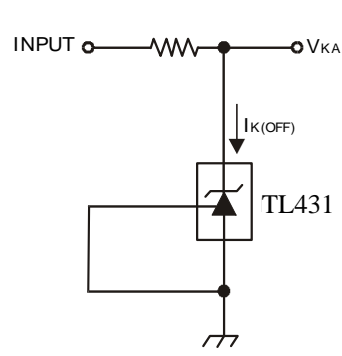
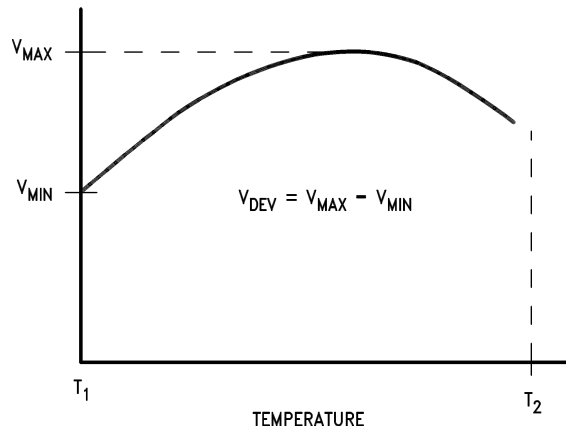

Figure 3. Test Circuit for I_{off}



Electrical Characteristics (Continued)



The average temperature coefficient of the reference input voltage, ∞V_{REF} , is defined as:

$$\infty V_{REF} \frac{\text{ppm}}{^{\circ}\text{C}} = \frac{\pm \left[\frac{V_{MAX} - V_{MIN}}{V_{REF} \text{ (at } 25^{\circ}\text{C)}} \right] 10^6}{T_2 - T_1} = \frac{\pm \left[\frac{V_{DEV}}{V_{REF} \text{ (at } 25^{\circ}\text{C)}} \right] 10^6}{T_2 - T_1}$$

Where:

$T_2 - T_1$ = full temperature change (0-70°C).

∞V_{REF} can be positive or negative depending on whether the slope is positive or negative.

Example: $V_{DEV} = 8.0 \text{ mV}$, $V_{REF} = 2495 \text{ mV}$, $T_2 - T_1 = 70^{\circ}\text{C}$, slope is positive.

$$\infty V_{REF} = \frac{\left[\frac{8.0 \text{ mV}}{2495 \text{ mV}} \right] 10^6}{70^{\circ}\text{C}} = +46 \text{ ppm}/^{\circ}\text{C}$$

Note 6: The dynamic output impedance, r_z , is defined as:

$$r_z = \frac{\Delta V_Z}{\Delta I_Z}$$

When the device is programmed with two external resistors, R_1 and R_2 , (see *Figure 2*), the dynamic output impedance of the overall circuit, r_z , is defined as:

$$r_z = \frac{\Delta V_Z}{\Delta I_Z} \cong \left[r_z \left(1 + \frac{R_1}{R_2} \right) \right]$$

Equivalent Circuit

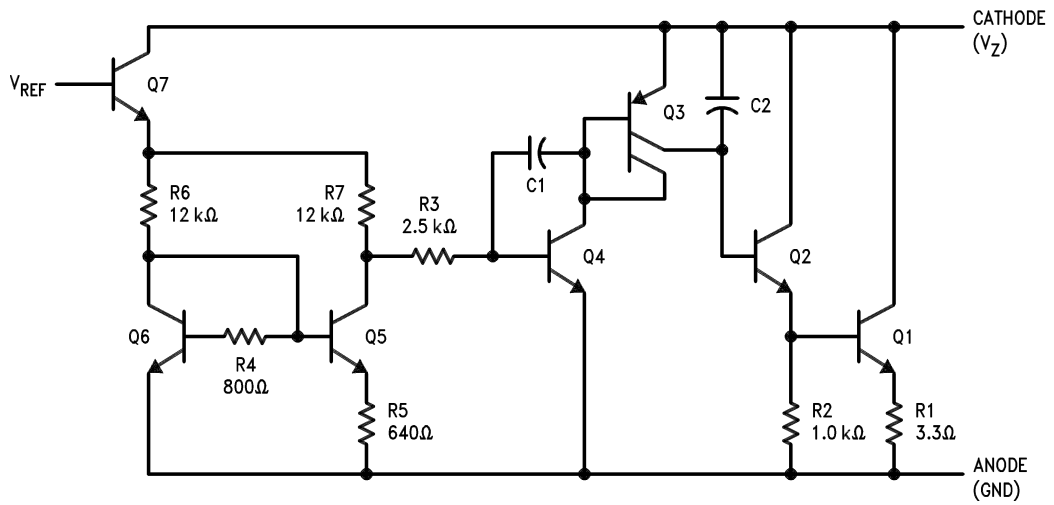

Typical Performance Characteristics

Input Current vs V_Z

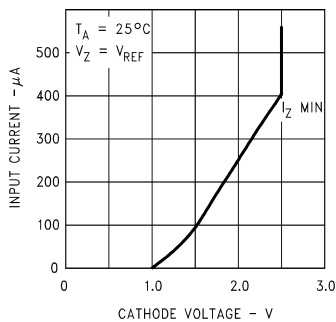

Thermal Information

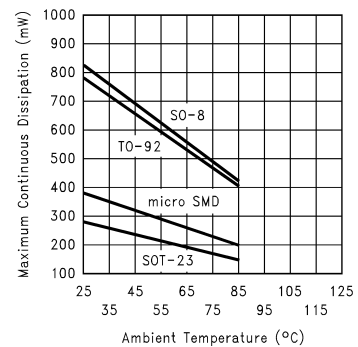

Input Current vs V_Z

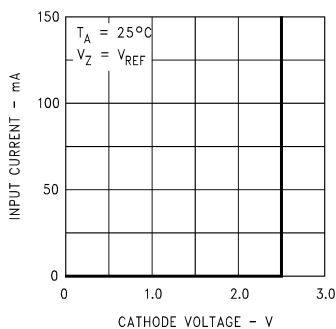

Dynamic Impedance vs Frequency

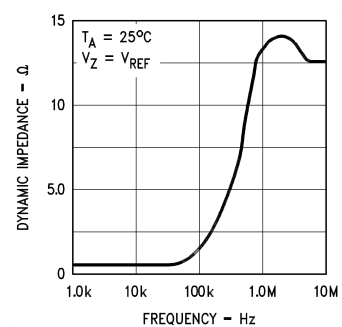

Typical Performance Characteristics (Continued)

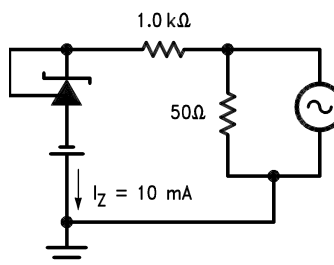
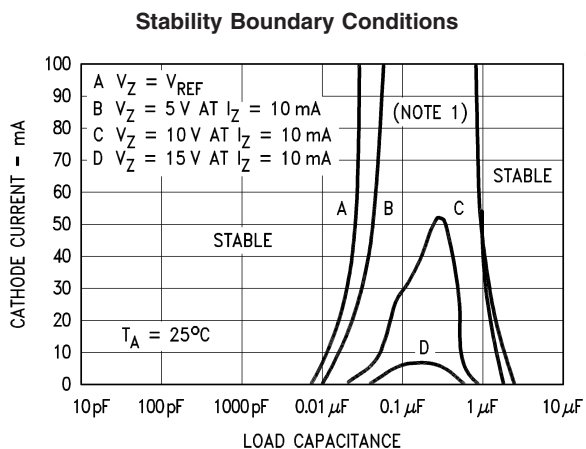

Note: The areas under the curves represent conditions that may cause the device to oscillate. For curves B, C, and D, R₂ and V₊ were adjusted to establish the initial V_Z and I_Z conditions with C_L = 0. V₊ and C_L were then adjusted to determine the ranges of stability.

Test Circuit for Curve A Above

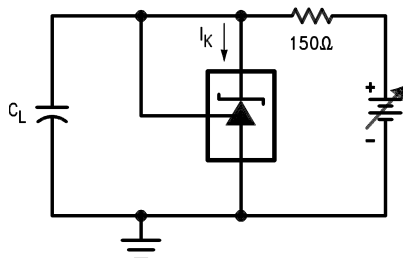

Test Circuit for Curves B, C and D Above

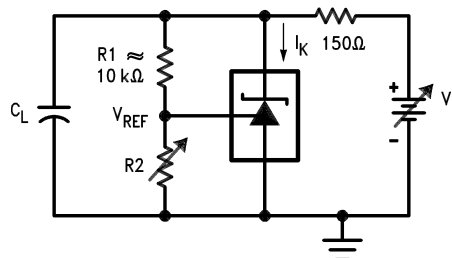

Typical Applications

Shunt Regulator

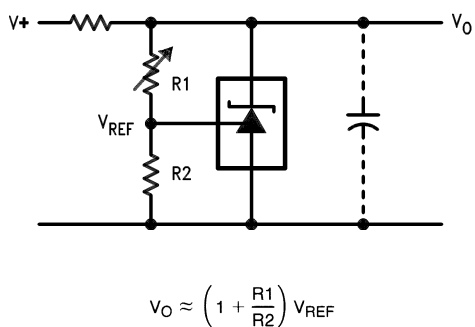

Single Supply Comparator with Temperature Compensated Threshold

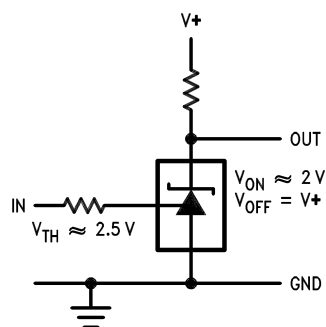

Typical Applications (Continued)

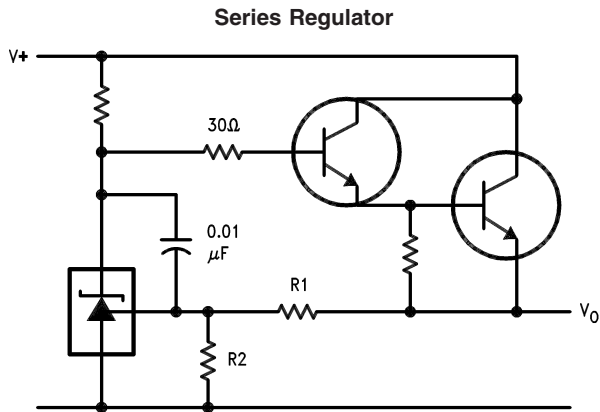

$$V_O \approx \left(1 + \frac{R_1}{R_2}\right) V_{REF}$$

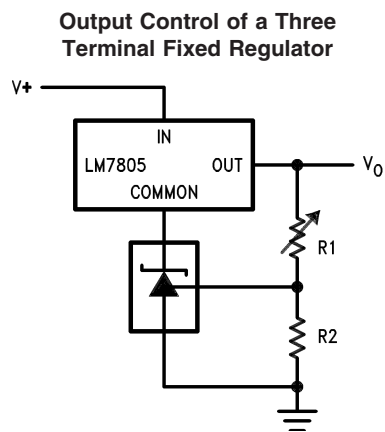

$$V_O = \left(1 + \frac{R_1}{R_2}\right) V_{REF}$$

$$V_{O\ MIN} = V_{REF} + 5V$$

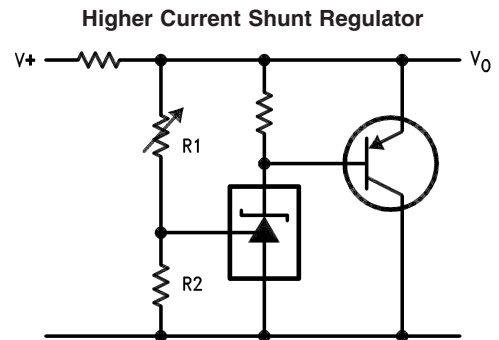

$$V_O \approx \left(1 + \frac{R_1}{R_2}\right) V_{REF}$$

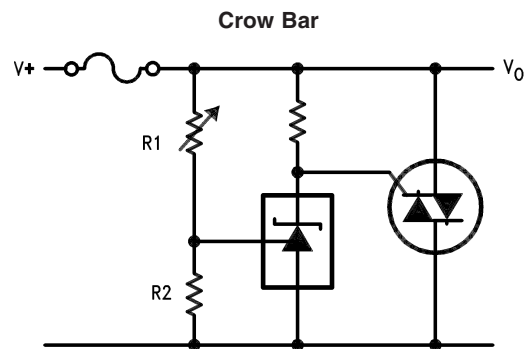

$$V_{LIMIT} \approx \left(1 + \frac{R_1}{R_2}\right) V_{REF}$$

Typical Applications (Continued)

Over Voltage/Under Voltage Protection Circuit

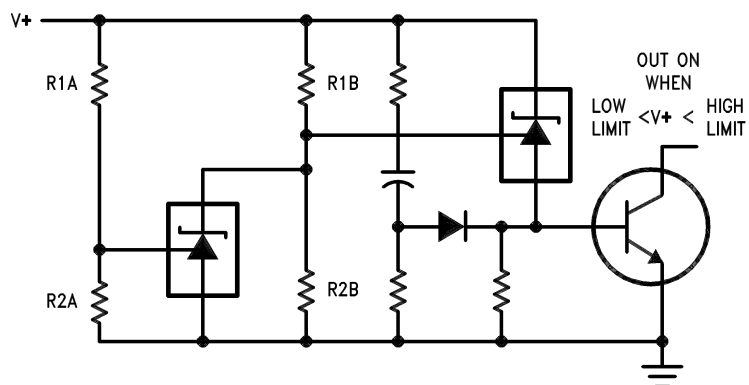

$$\text{LOW LIMIT} \approx V_{\text{REF}} \left(1 + \frac{R1B}{R2B} \right) + V_{\text{BE}}$$

$$\text{HIGH LIMIT} \approx V_{\text{REF}} \left(1 + \frac{R1A}{R2A} \right)$$

Voltage Monitor

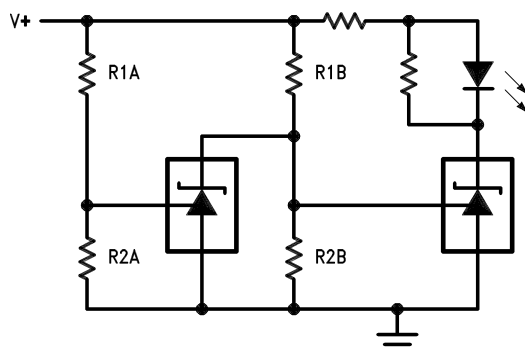

$$\text{LOW LIMIT} \approx V_{\text{REF}} \left(1 + \frac{R1B}{R2B} \right) \quad \text{LED ON WHEN} \\ \text{LOW LIMIT} < V^+ < \text{HIGH LIMIT}$$

$$\text{HIGH LIMIT} \approx V_{\text{REF}} \left(1 + \frac{R1A}{R2A} \right)$$

Typical Applications (Continued)

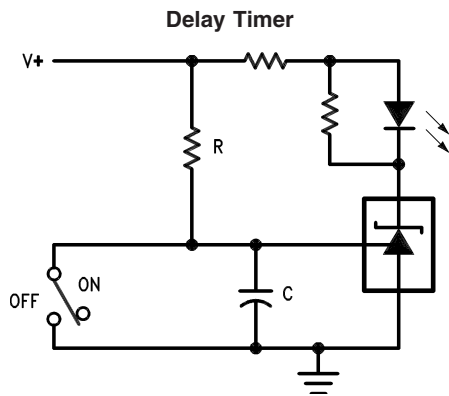

$$\text{DELAY} = R \cdot C \cdot \ln \frac{V+}{(V+) - V_{\text{REF}}}$$

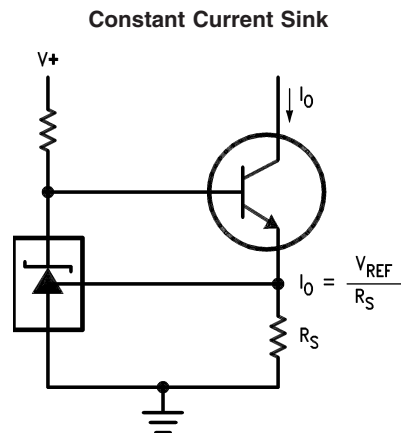
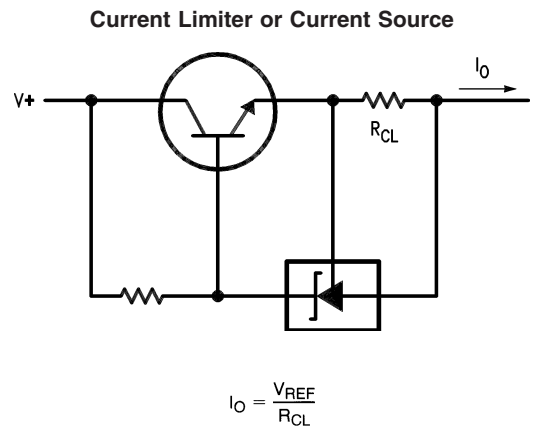

Ordering Information

Product Number	Reference Input Voltage	Package
TL431CLF TL431CLS	0.5%	TO-92
TL431CD		8-SOP
TL431CS		SOT-23
TL431CP		SOT-89
TL431ALF TL431ALS	1%	TO-92
TL431AD		8-SOP
TL431AS		SOT-23
TL431AP		SOT-89
TL431LF TL431LS	2%	TO-92
TL431D		8-SOP
TL431S		SOT-23
TL431P		SOT-89

Package Dimensions

D SUFFIX SOIC
(MS - 012AA)

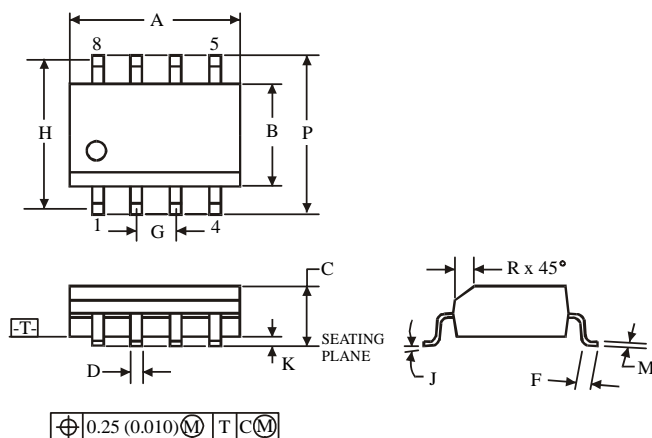
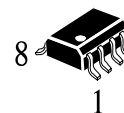

Symbol	Dimension, mm	
	MIN	MAX
A	4.80	5.00
B	3.80	4.00
C	1.35	1.75
D	0.33	0.51
F	0.40	1.27
G	1.27	
H	5.72	
J	0°	8°
K	0.10	0.25
M	0.19	0.25
P	5.80	6.20
R	0.25	0.50

NOTES:

- Dimensions A and B do not include mold flash or protrusion.
- Maximum mold flash or protrusion 0.15 mm (0.006) per side for A; for B - 0.25 mm (0.010) per side.

TO-92

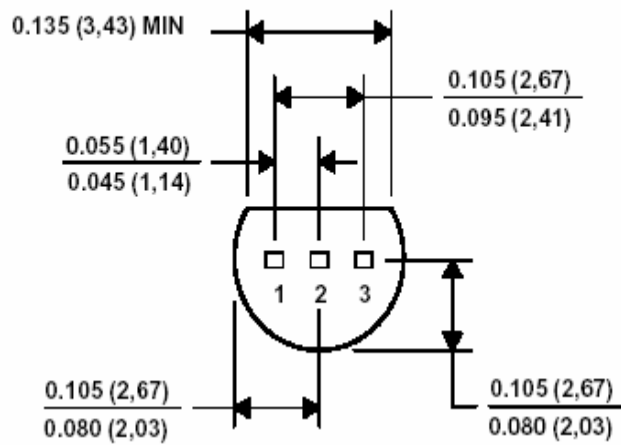
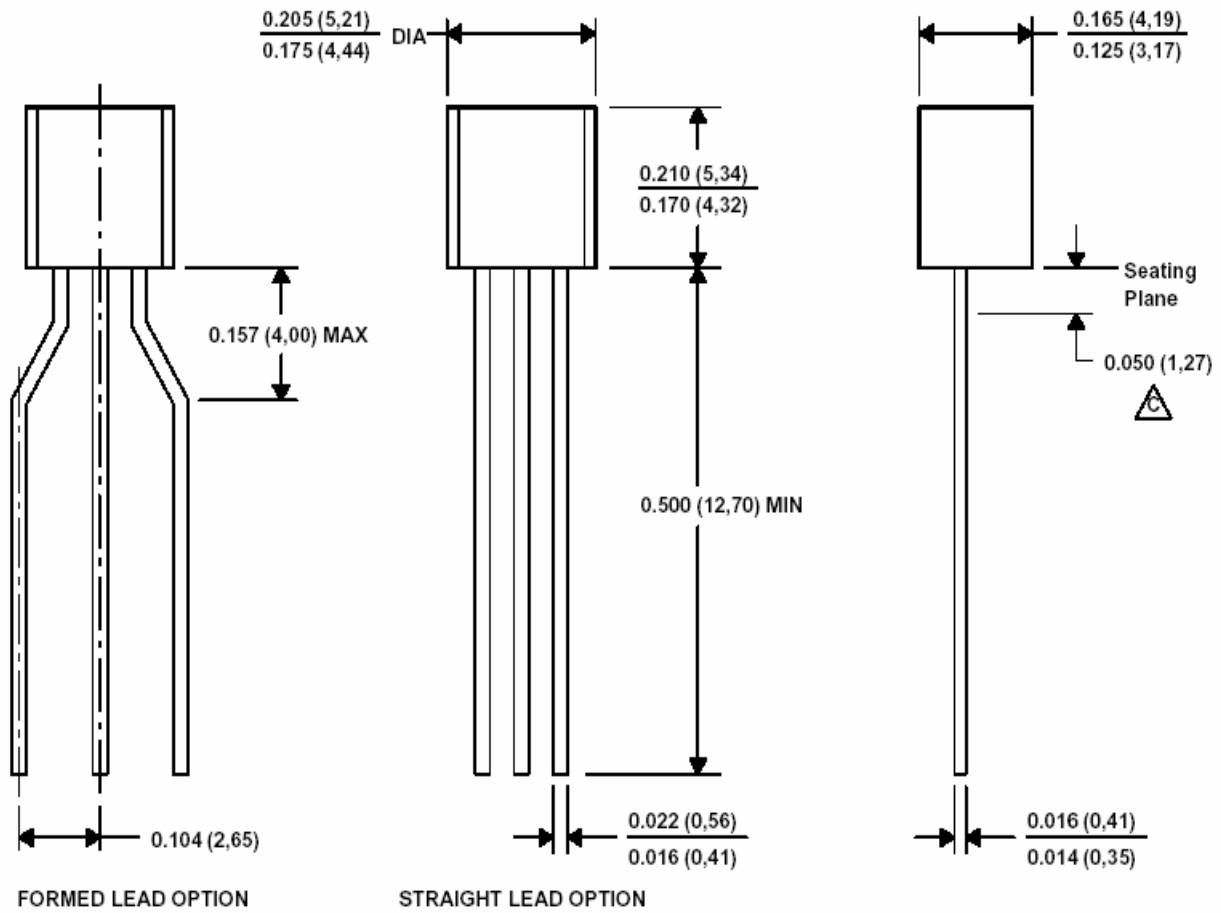

SOT-23-3L PACKAGE OUTLINE DIMENSIONS

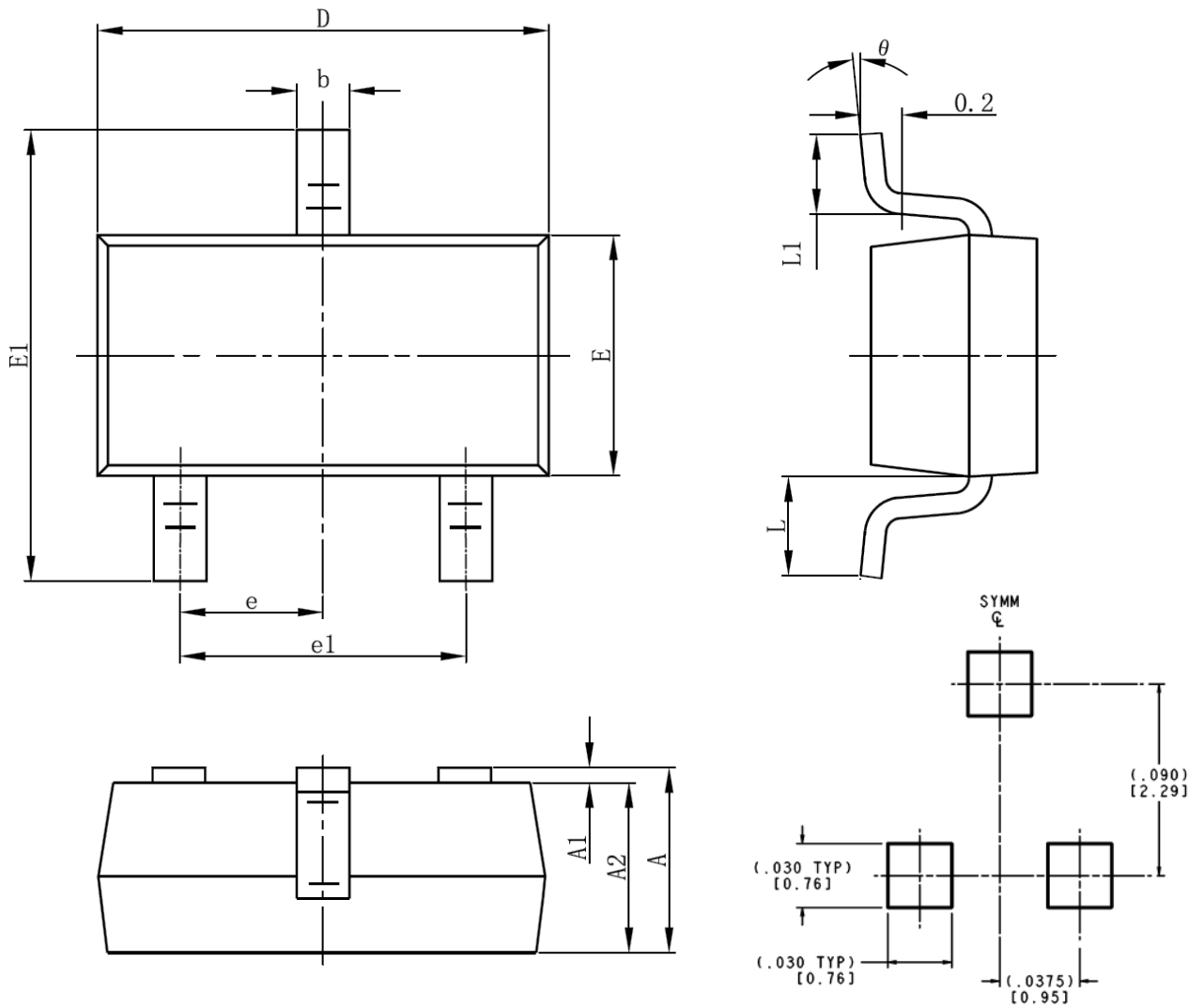

LAND PATTERN RECOMMENDATION

Symbol	Dimensions In Millimeters		Dimensions In Inches	
	Min	Max	Min	Max
A	1.050	1.250	0.041	0.049
A1	0.000	0.100	0.000	0.004
A2	1.050	1.150	0.041	0.045
b	0.300	0.400	0.012	0.016
c	0.100	0.200	0.004	0.008
D	2.820	3.020	0.111	0.119
E	1.500	1.700	0.059	0.067
E1	2.650	2.950	0.104	0.116
e	0.950TYP		0.037TYP	
e1	1.800	2.000	0.071	0.079
L	0.700REF		0.028REF	
L1	0.300	0.600	0.012	0.024
θ	0°	8°	0°	8°

SOT-89-3L PACKAGE OUTLINE DIMENSIONS

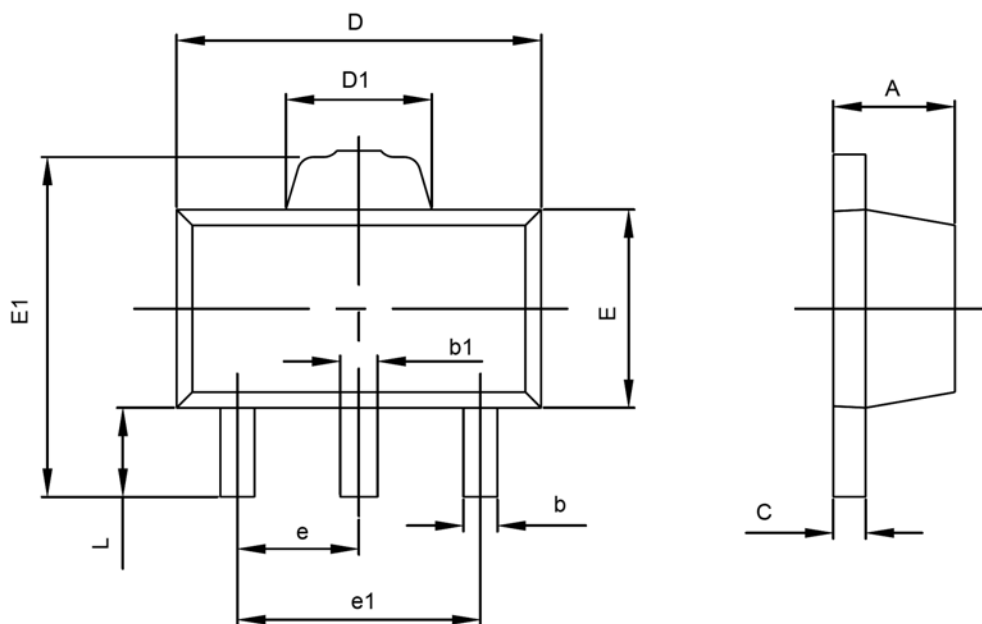

Symbol	Dimensions In Millimeters		Dimensions In Inches	
	Min	Max	Min	Max
A	1.400	1.600	0.055	0.063
b	0.320	0.520	0.013	0.020
b1	0.360	0.560	0.014	0.022
c	0.350	0.440	0.014	0.017
D	4.400	4.600	0.173	0.181
D1	1.400	1.800	0.055	0.071
E	2.300	2.600	0.091	0.102
E1	3.940	4.250	0.155	0.167
e	1.500TYP		0.060TYP	
e1	2.900	3.100	0.114	0.122
L	0.900	1.100	0.035	0.043