

REVISE MARK	ECN, NO.	DESCRIPTION	DR	CHK.	DATE

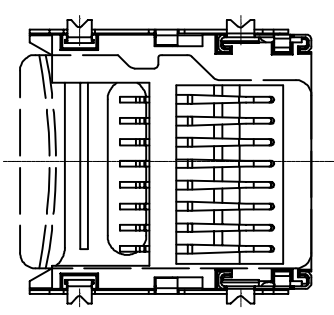

SLIDE SHELL OPEN

SLIDE SHELL LOCK

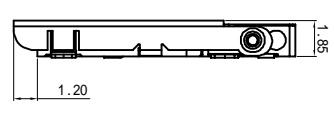
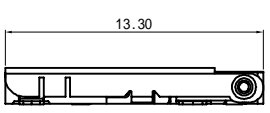
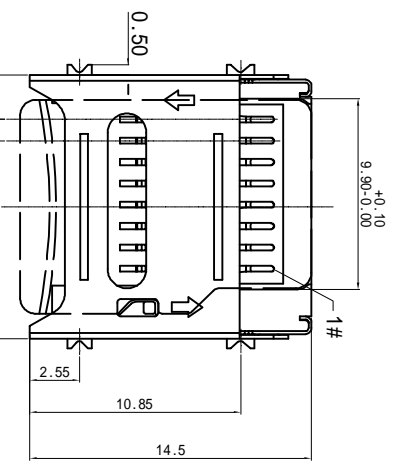
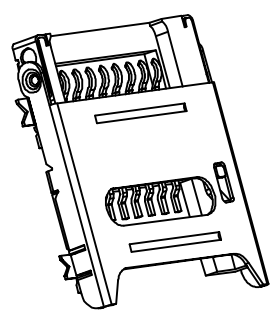

SPECIFICATION

1. ELECTRICAL CHARACTERISTICS:
 CONTACT CURRENT RATING: 0.5 AMPERES.
 DIELECTRIC WITHSTANDING VOLTAGE: AC500V r.m.s.
 INSULATION RESISTANCE: 100 Megohms MINIMUM.
 CONTACT RESISTANCE: 100 Milliohms MAXIMUM.

2. ENVIRONMENTAL:
 OPERATING TEMPERATURE: -25°C~+85°C.

3. MECHANICAL:
 DURABILITY: 5,000 CYCLES.

4. MATERIAL:
 HOUSING: HI-TEMP PLASTIC UL94V-0 RATED.
 CONTACT: COPPER ALLOY.

SHELL: STAINLESS STEEL (T=0.20mm)
 5. HARMFUL MATERIAL SHOULD BE COMPLIANT TO DOC"EI-0005" STANDARDS.

RECOMMENDED PCB LAYOUT
 TOP VIEW (TOLERANCE: ±0.05)

NO.	PIN NAME
1#	DAT2
2#	CD/DAT3
3#	CMD
4#	VDD
5#	CLK
6#	VSS
7#	DAT0
8#	DAT1

GENERAL TOLERANCE 一般公差	
±0.30	±3°
±0.25	±3°
±0.20	±3°
±0.05	±0.05

TYPE	TITLE	SIZE	SHEET	REV.
PUSH CONN	T-FLASH04	YXD5.232.153	1:1	C1

