



Power Resistors / 功率电阻

●	High Voltage Power Resistors - BOX Series / 组合式功率电阻箱 -----	1
●	Power Resistor Chamber / 大功率负载柜电阻箱 -----	2
●	Variable Power Resistors - BSR, BSQ Series / 摺动式线绕功率电阻器 -----	3
●	Wirewound Power Resistors - DR Series / 绕线功率电阻器 -----	4
●	Power Resistors - DST Series / 功率线绕电阻器 -----	8
●	Variable Resistors Power Type - FVR Series / 线绕可变电阻 -----	9
●	Power Resistor Aluminum Housed - AH Series / 功率铝壳电阻 -----	11
●	Power Resistors - AL Series / 线绕大电力铝壳电阻 -----	17
●	High Power Resistors - DQ Series / 不燃性波浪线绕功率电阻器 -----	20
●	Wirewound Power Resistors - ZZR Series / 绕线功率电阻器 -----	23
●	Wirewound Power Resistors - ZQN Series / 绕线功率电阻器 -----	25
●	High Current Oval Edge-wound - DOE Series / 功率高电流椭圆形板式电阻 -----	26
●	Power Resistors Assembly Method / 功率电阻组合方式 -----	28



<http://www.token.com.tw>



rfq@tokenonline.net

Taiwan: No. 137, Sec. 1, Chung Shin Rd., Wu Ku Hsiang, Taipei Hsien, Taiwan, R.O.C
TEL: 886-2-2981 0109; FAX: 886-2-2988 7487

China: 3F South, Zhongxing Industry Bld., Chuangye Rd., Nanshan District, Shenzhen, Guangdong
TEL: 86-755-2605 5363, 2605 5364; FAX: 86-755-2605 5365



Power Resistors

High Voltage Power Resistors - BOX Series

Power Resistor BOX Series

An assembly-type enclosure contains DR series of and/or DQ series. The box offers excellent protection and safety, in that it not only provides high power load capability and durability, excellent heat dissipation, and a low temperature coefficient that is directly proportional, but also accommodates a flexible range of assembly options for convenient utilization and installation (Refer to the DR series and DQ series features for exact specifications). Suitable for educational modeling applications, load testing, industrial machinery, electric power distribution, instruments and automation control installations, etc. For custom specifications, please contact us to discuss the details.



► High Voltage Power Resistors - BDR Type 200W - 3200W Assembly-type Resistance Box

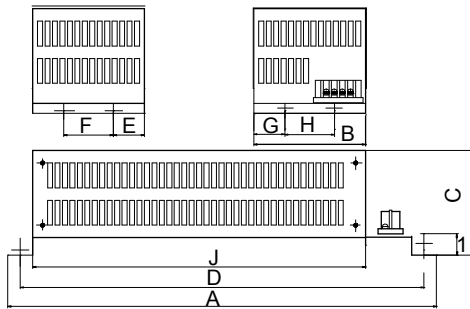

Power Rating	Dimensions(mm)											Resistance Range(Ω)
	CASE	A	B	C	D	E	F	G	H	I	J	
200W	A	345	90	76	325	45		43		8	268	0.1~100K Ω
400W	A	345	90	76	325	45		43		8	268	0.1~200K Ω
400W	B	450	152	100	428	30	90	74		10	355	0.1~200K Ω
800W	B	450	152	100	428	30	90	74		10	355	0.1~400K Ω
1200W	C	450	300	100	428	74	146	74	146	10	355	0.1~600K Ω
1600W	C	450	300	100	428	74	146	74	146	10	355	0.1~800K Ω
2000W	D	560	250	195	535	27	190	122		10	420	0.1~1000K Ω
2400W	D	560	250	195	535	27	190	122		10	420	0.1~1200K Ω
2800W	D	560	250	195	535	27	190	122		10	420	0.1~1400K Ω
3200W	D	560	250	195	535	27	190	122		10	420	0.1~1600K Ω

► High Voltage Power Resistors - BQR Type 300W - 4800W Assembly-type Resistance Box

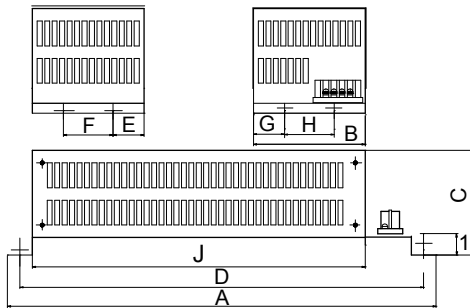

Power Rating	Dimensions(mm)											Resistance Range(Ω)
	CASE	A	B	C	D	E	F	G	H	I	J	
300W	A	345	90	76	325	45		43		8	268	0.1~30 Ω
600W	A	345	90	76	325	45		43		8	268	0.1~60 Ω
600W	B	450	152	100	428	30	90	74		10	355	0.1~60 Ω
1200W	B	450	152	100	428	30	90	74		10	355	0.1~120 Ω
1800W	C	450	300	100	428	74	146	74	146	10	355	0.1~180 Ω
2400W	C	450	300	100	428	74	146	74	146	10	355	0.1~240 Ω
3000W	D	560	250	195	535	27	190	122		10	420	0.1~300 Ω
3600W	D	560	250	195	535	27	190	122		10	420	0.1~360 Ω
4200W	D	560	250	195	535	27	190	122		10	420	0.1~420 Ω
4800W	D	560	250	195	535	27	190	122		10	420	0.1~480 Ω

Notice: All dimensions might be changed or modified, please refer to last updating specification.

► How to Order



- ① Product Type: BDR type, BQR type
- ② Rated Power: 200W~3200W, 300W~4800W
- ③ Resistance Value (Ω): (Ω) Indicates resistance value in units of ohms.

④ Resistance Tolerance

Code	Resistance Tolerance
J	$\pm 5\%$
K	$\pm 10\%$



Power Resistors

Power Resistor Chamber

Token produces various kinds of Power Resistor Chambers which can be used for any AC or DC power application. Units are most commonly used for motor acceleration and braking, load banks, harmonic filtering and neutral grounding applications.

▶ Power Resistor Chamber Assembly:

All units are coiled consist of stainless steel edge wound non-inductive elements wound around core which is mounted on a stainless steel rod. Glazed insulators are attached to each end of the coils and fastened to a heavy gage, corrosion resistant frame. Resistor elements are joined by stainless connectors to form a positive electrical path.



▶ Power Resistor Chamber Safety Enclosure:

Token resistor assemblies are available with grounded safety enclosures to protect personnel and wildlife from harm. Screened and louvered enclosures are available in a variety of finishes including painted, powder coated, mill galvanized, hot-dipped galvanized, aluminum and stainless steel.

▶ Power Resistor Chamber Option:

A number of additional options are available including entrance bushings, current transformers, elevating stands and disconnect switches.



▶ RNW-T Type

Electric Parameter and External Dimensions

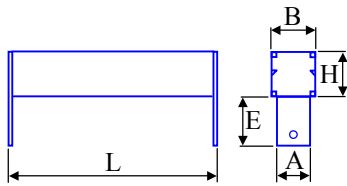

Type	Wattage (W)	Dimensions (mm)				
		L	H	B	A	E
T5	5	35	9	9	6	15
T10	10	48	10	10	6	15
T20	20	64	14	14	8	20
T30	30	75	19	19	8	20
T50	50	88	20	20	10	20
T100	100	135	25	25	10	25

▶ RNW-B Type

Electric Parameter and External Dimensions

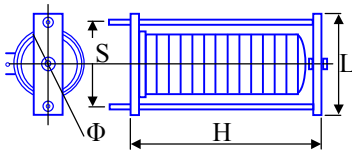

Series	Resistance Range(Ω)	Capacity (KJ)	Dimensions(mm)			Mounting Hole		
			Ø	H	L	Quantity[N]	Diameter[Ø]	Center Spacing[S]
B11	0.5-30	400	110	190	185	2	10.5	158
B12	0.5-60	800	110	290	185	2	10.5	158
B13	0.5-90	1200	110	390	185	2	10.5	158
B21	0.5-30	300	110	214	254	2	10.5	238
B22	0.5-60	600	110	370	410	2	10.5	294
B23	0.5-90	900	110	526	566	2	10.5	550

▶ RNW-H Type

Electric Parameter and External Dimensions

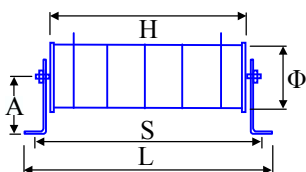

Series	Rated Wattage (W)	Resistance Range (Ω)	Dimensions(mm)			Mounting Hole			Center Height [A]
			Ø	H	L	Quantity [N]	Diameter [Ø]	Center Spacing[S]	
H	200	1-30	100	134	174	2	8.5	158	90
	400	2-60	100	194	234	2	8.5	218	
	500	3-90	100	254	294	2	8.5	278	
	750	4-120	100	314	354	2	8.5	338	
	1000	5-150	100	374	414	2	8.5	398	

Notice: All dimensions might be changed or modified, please refer to last updating specification.



Power Resistors

BSR, BSQ Series - Variable Power Resistors / 摺动式线绕功率电阻器

BSR, BSQ Series

A tubular ceramic form has copper-alloy or chromium-alloy windings as a resistance element, with the mount attachment method the same as the other described. Except for the sliding contact surface on the windings, the entire component is coated with a high-temperature non-flammable resin. The adjustment mechanism is a rotating point that slides directly on the resistance element, which allows variation of the resistance value (See the specifications of the DR series and VR series for exact features). Suitable for education, testing, load simulations, automation control installations, etc. For custom specifications, please contact us to discuss the details.

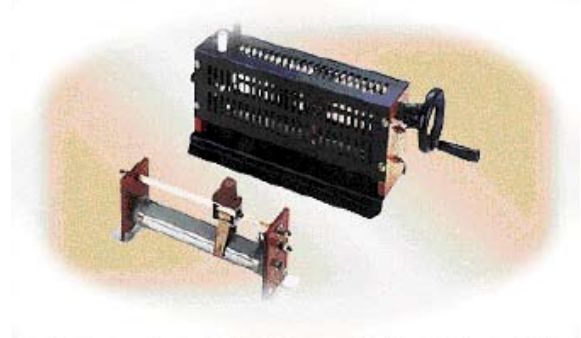

▶ Variable Power Resistor BSR Type 200W - 1300W

Variable Slide-type

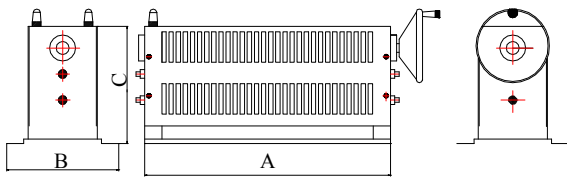

Wattage Rating	Dimensions(mm)						Resistance Range(Ω)
	Case	A	B	C	Ceramic Rod	Bakelite	
200W	A	285	130	135	28×250	120×70×10	0.5-2K Ω
400W	B	360	150	185	40×325	170×90×10	0.5-4K Ω
500W	B	360	150	185	40×325	170×90×10	0.5-5K Ω
1000W	C	570	160	200	60×535	185×100×10	0.5-10K Ω
1300W	D	680	160	200	65×645	185×100×10	0.5-13K Ω

Notice: All dimensions might be changed or modified, please refer to last updating specification.

▶ How to Order

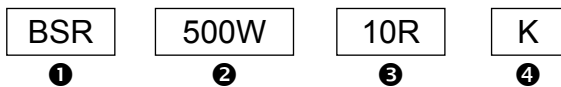

❶ Product Type: BSR type

❷ Rated Wattage: 200W~1300W

❸ Resistance Value(Ω):(Ω) Indicates Resistance Value in Units of Ohms.

❹ Resistance Tolerance:K($\pm 10\%$)

▶ Variable Power Resistor BSQ Type 300W - 2000W

Variable Slide-type Wave

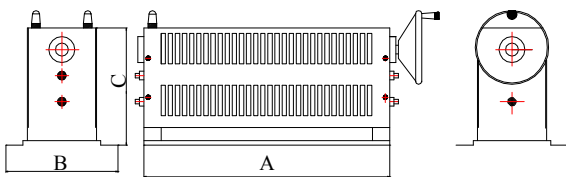

Wattage Rating	Dimensions(mm)						Resistance Range(Ω)
	Case	A	B	C	Ceramic Rod	Bakelite	
300W	A	285	130	135	28×250	120×70×10	0.5-30 Ω
600W	B	360	150	185	40×325	170×90×10	0.5-60 Ω
750W	B	360	150	185	40×325	170×90×10	0.5-75 Ω
1500W	C	570	160	200	60×535	185×100×10	0.5-150 Ω
2000W	D	680	160	200	65×645	185×100×10	0.5-200 Ω

Notice: All dimensions might be changed or modified, please refer to last updating specification.

▶ How to Order



❶ Product Type: BSQ type

❷ Rated Wattage: 300W~2000W

❸ Resistance Value(Ω):(Ω) Indicates Resistance Value in Units of Ohms.

❹ Resistance Tolerance:K($\pm 10\%$)



Power Resistors

Wirewound Power Resistors - DR Series

Wirewound Power Resistors - A tubular ceramic has two terminals, and is wound with copper wire or chromium alloy wire to provide the resistance and then coated with a high temperature, non-flammable resin. After the semi-finished part is cool and dry, insulation is applied through a high-temperature process and the mounts are attached. Since the winding is excellent, many taps can be added, impedance is low and the shape can be altered to produce many types. DR series is suitable for educational modeling applications, load testing, industrial machinery, electric power distribution, instruments, automation control installations, etc. For custom specifications, please contact us to discuss the details.

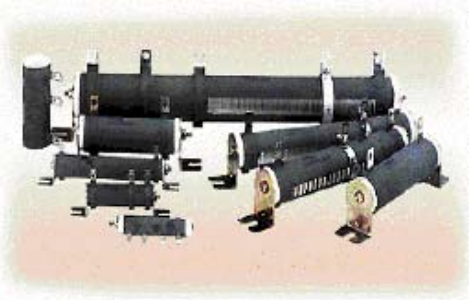

► DDR Type 10W - 1300W Tubular Ceramic, Fixed-type - Wirewound Power Resistors

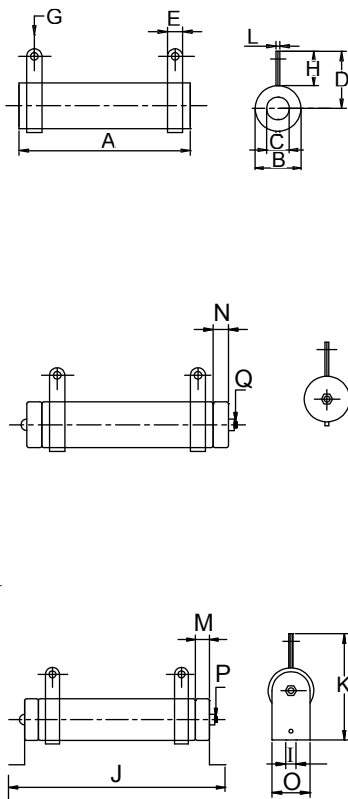

Wattage Rating	Dimensions(mm)															Resistance Range(Ω)
	A	B	C	D	E	F	G	H	I	J	K	L	M	N	O	
10W	45	12	6	15	4	54	2	9	3	62	28	1.0	0	6	10	1~3K Ω
20W	60	17	8	22	5	78	2	12	4	90	36	1.0	0	6	16	1~7K Ω
30W	80	17	8	22	5	100	2	12	4	112	36	1.0	0	6	16	1~10K Ω
40W	110	17	8	22	5	128	2	12	4	140	36	1.0	0	6	16	1~13K Ω
50W	110	25	16	30	8	150	5	18	6	166	58	1.2	6	0	27	0.1~25K Ω
60W	90	28	18	32	8	130	5	19	6	146	60	1.2	6	0	27	0.1~30K Ω
80W	110	28	18	32	8	150	5	19	6	166	60	1.2	6	0	27	0.1~40K Ω
100W	140	28	18	32	8	180	5	19	6	196	60	1.2	6	0	27	0.1~50K Ω
120W	160	28	18	32	8	200	5	19	6	216	60	1.2	6	0	27	0.1~60K Ω
150W	195	28	18	32	8	235	5	19	6	251	60	1.2	6	0	27	0.3~75K Ω
160W	185	35	24	36	10	225	5	19	8	245	76	1.6	6	0	34	0.3~80K Ω
200W	210	35	24	36	10	250	5	19	8	274	76	1.6	6	0	34	0.3~100K Ω
250W	210	40	25	38	12	250	5	20	8	274	78	1.6	6	0	34	0.5~125K Ω
300W	260	40	25	38	12	300	5	20	8	320	78	1.6	6	0	34	0.5~150K Ω
400W	330	40	25	38	12	370	5	20	8	395	78	1.6	6	0	34	0.5~200K Ω
500W	330	50	35	50	12	380	6	25	9	400	100	1.6	8	0	40	0.5~250K Ω
600W	400	50	35	50	12	450	6	25	9	470	100	1.6	8	0	40	0.8~300K Ω
700W	460	50	35	50	12	510	6	25	9	530	100	1.6	8	0	40	0.8~350K Ω
800W	460	60	40	55	15	515	6	30	10	535	110	1.6	10	0	50	0.8~400K Ω
1000W	540	60	40	55	15	595	6	30	10	615	110	1.6	10	0	50	1~500K Ω
1300W	650	65	42	62	15	702	6	30	10	722	115	1.6	10	0	50	1~750K Ω

Notice: All dimensions might be changed or modified, please refer to last updating specification.



Power Resistors

► Wirewound Power Resistor DCR Type 100W - 250W Tubular Ceramic, C - shaped

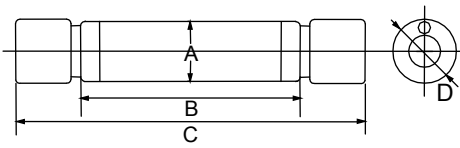

Wattage Rating	Dimensions(mm)				Resistance Range(Ω)
	A	B	C	D	
100W	28	140	165	30	20~20KΩ
120W	28	165	190	30	25~25KΩ
150W	28	195	220	30	30~30KΩ
200W	28	254	279	30	35~35KΩ
250W	28	300	325	30	40~40KΩ

Notice: All dimensions might be changed or modified, please refer to last updating specification.

► How to Order

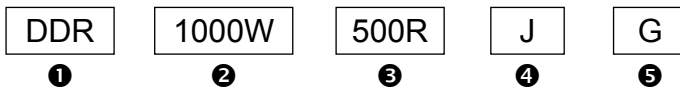

① Product Type: DDR type
DCR type

② Rated Power: 10W~1300W
100W~250W

③ Resistance Value(Ω) : (Ω)
indicates resistance
value in units of ohms.

④ Resistance Tolerance

Code	Resistance Tolerance
J	±5%
K	±10%

⑤ Assembly Method

Code	Assembly Method
C	Clip Mount.
G	Horizontal Mount.
N	No Mount.
Z	Vertical Mount.

► Wirewound Power Resistor DNR Type 50W - 1300W Tubular Ceramic, Low Inductive

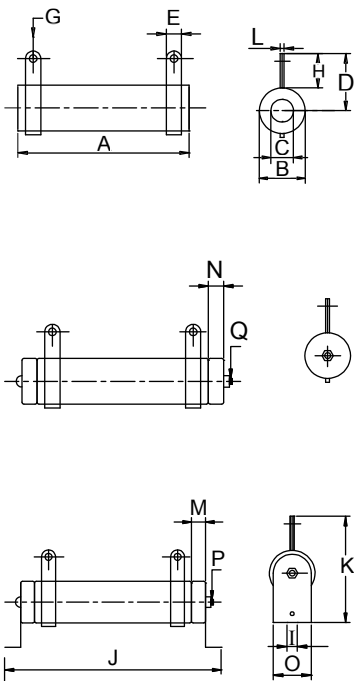

Wattage Rating	Dimensions(mm)															Resistance Range(Ω)
	A	B	C	D	E	F	G	H	I	J	K	L	M	N	O	
50W	110	25	16	30	8	150	5	18	6	166	58	1.2	6		27	0.1~10K Ω
60W	90	28	18	32	8	130	5	19	6	146	60	1.2	6		27	0.1~12K Ω
80W	110	28	18	32	8	150	5	19	6	166	60	1.2	6		27	0.1~16K Ω
100W	140	28	18	32	8	180	5	19	6	196	60	1.2	6		27	0.1~20K Ω
120W	160	28	18	32	8	200	5	19	6	216	60	1.2	6		27	0.1~24K Ω
150W	195	28	18	32	8	235	5	19	6	251	60	1.2	6		27	0.3~3K Ω
160W	185	35	24	36	10	225	5	19	8	245	76	1.6	6		34	0.3~35K Ω
200W	210	35	24	36	10	250	5	19	8	274	76	1.6	6		34	0.3~40K Ω
250W	210	40	25	38	12	250	5	20	8	274	78	1.6	6		34	0.5~50K Ω
300W	260	40	25	38	12	300	5	20	8	320	78	1.6	6		34	0.5~60K Ω
400W	330	40	25	38	12	370	5	20	8	395	78	1.6	6		34	0.5~80K Ω
500W	330	50	35	50	12	380	6	25	9	400	100	1.6	8		40	0.5~100K Ω
600W	400	50	35	50	12	450	6	25	9	470	100	1.6	8		40	0.8~120K Ω
700W	460	50	35	50	12	510	6	25	9	530	100	1.6	8		40	0.8~140K Ω
800W	460	60	40	55	15	515	6	30	10	535	110	1.6	10		50	0.8~160K Ω
1000W	540	60	40	55	15	595	6	30	10	615	110	1.6	10		50	1~200K Ω
1300W	650	65	42	62	15	702	6	30	10	722	115	1.6	10		50	1~260kΩ

Notice: All dimensions might be changed or modified, please refer to last updating specification.



Power Resistors

► Wirewound Power Resistor DSR Type 20W - 1300W Tubular Ceramic, Variable

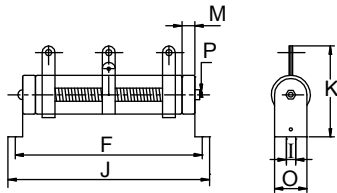
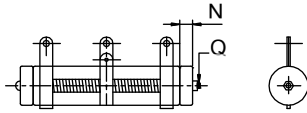
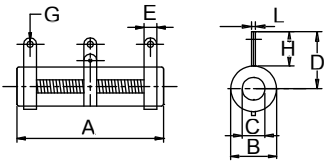

Wattage Rating	Dimensions(mm)															Resistance Range(Ω)
	A	B	C	D	E	F	G	H	I	J	K	L	M	N	O	
20W	60	17	8	22	5	78	2	12	4	90	36	1.0		6	16	1~1K Ω
30W	80	17	8	22	5	100	2	12	4	112	36	1.0		6	16	1~1.5K Ω
40W	110	17	8	22	5	128	2	12	4	140	36	1.0		6	16	1~2K Ω
50W	110	25	16	30	8	150	5	18	6	166	58	1.2	6		27	0.1~5K Ω
60W	90	28	18	32	8	130	5	19	6	146	60	1.2	6		27	0.1~6K Ω
80W	110	28	18	32	8	150	5	19	6	166	60	1.2	6		27	0.1~8K Ω
100W	140	28	18	32	8	180	5	19	6	196	60	1.2	6		27	0.1~10K Ω
120W	160	28	18	32	8	200	5	19	6	216	60	1.2	6		27	0.1~12K Ω
150W	195	28	18	32	8	235	5	19	6	251	60	1.2	6		27	0.3~15K Ω
160W	185	35	24	36	10	225	5	19	8	245	76	1.6	6		34	0.3~16K Ω
200W	210	35	24	36	10	250	5	19	8	274	76	1.6	6		34	0.3~20K Ω
250W	210	40	25	38	12	250	5	20	8	274	78	1.6	6		34	0.5~25K Ω
300W	260	40	25	38	12	300	5	20	8	320	78	1.6	6		34	0.5~30K Ω
400W	330	40	25	38	12	370	5	20	8	395	78	1.6	6		34	0.5~40K Ω
500W	330	50	35	50	12	380	6	25	9	400	100	1.6	8		40	0.5~50K Ω
600W	400	50	35	50	12	450	6	25	9	470	100	1.6	8		40	0.8~60K Ω
700W	460	50	35	50	12	510	6	25	9	530	100	1.6	8		40	0.8~70K Ω
800W	460	60	40	55	15	515	6	30	10	535	110	1.6	10		50	0.8~80K Ω
1000W	540	60	40	55	15	595	6	30	10	615	110	1.6	10		50	1~100K Ω
1300W	650	65	42	62	15	702	6	30	10	722	115	1.6	10		50	1~130K Ω

Notice: All dimensions might be changed or modified, please refer to last updating specification.

► How to Order

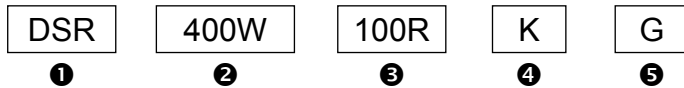

❶ Product Type: DNR type
DSR type

❷ Rated Power: 50W~1300W
20W~1300W

❸ Resistance Value(Ω): (Ω)
indicates resistance value in units of ohms.

❹ Resistance Tolerance

Code	Resistance Tolerance
J	$\pm 5\%$
K	$\pm 10\%$

❺ Assembly Method

Code	Assembly Method
C	Clip Mount.
G	Horizontal Mount.
N	No Mount.
Z	Vertical Mount.



Power Resistors

► Nonflammable Wirewound Power Resistors Performance Specifications

Test Item	Test Methods	Characteristics
Resistance tolerance	JIS-C-5202 5-1	Resistance Nominal Tolerance 1≤R 1>R ±5%(J) ±10%(K)
Temperature coefficient	JIS-C-5202 5-2	±200PPM/°C MAX
Load rating	JIS-C-5202 5-4	ΔR/R≤±(0.5%+0.1Ω) Surface temperature up 350°C MAX
Short-term overload	JIS-C-5202 5-5 1000% rated wattage 5 seconds	Free of appearance or structural irregularity ΔR/R≤ ±(2%+0.1Ω)
Insulation resistance	JIS-C-5202 5-6 500VDC	100MΩ min
Dielectric withstanding voltage	JIS-C-5202 5-7 1000VDC 1 minute Between terminal and anchor stand	Free of appearance or structural irregularity ΔR/R≤ ±(0.1%+0.05Ω)
Terminal strength	JIS-C-5202 6-1 8kg 30 seconds	Free of appearance or structural irregularity
Vibration	JIS-C-5202 6-3 1.5m/m 10 ~ 50 ~ 10 Hz/min X-Y-Z 2 hours each	Free of appearance or structural irregularity Surface coating crack ΔR/R≤ ±(1%+0.05Ω)
Thermal shock	JIS-C-5202 7-3 Room temp 30 minutes ON-55°C 15 minutes OFF	Free of structural irregularity ΔR/R≤ ±(2%+0.1Ω)
Humidity	JIS-C-5202 7-5 40°C 90%RH 240 hours	Free of appearance or structural irregularity Surface coating crack ΔR/R≤ ±(3%+0.1Ω)
Load life	JIS-C-5202 7-10 90 minutes ON - 30 minutes OFF 500 hours	Free of appearance or structural irregularity Surface coating crack ΔR/R≤ ±(1%+0.05Ω)
Flame retardation	JIS-C-5202 7-13-3-2 100% - 600% rated wattage load	US UL-94 flame retardation test V-0 grade noncombustible
REMARKS:	1. Resistance and resistance tolerance were tested in-house with micro resistance meter. 2. Coating refers to UL-certified data provided by supplier.	

► Nonflammable Wirewound Power Resistors How to Order

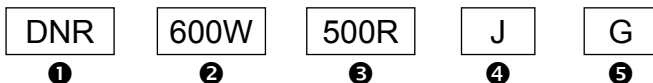

① Product Type: DDR type
DNR type
DSR type
DCR type

② Rated wattage: 10W~1300W
50W~1300W
20W~1300W
100W~250W

③ Resistance Value(Ω): (Ω)
indicates resistance
value in units of ohms.

④ Resistance Tolerance

Code	Resistance Tolerance
J	±5%
K	±10%

⑤ Assembly Method

Code	Assembly Method
C	Clip Mount.
G	Horizontal Mount.
N	No Mount.
Z	Vertical Mount.



Power Resistors

DST Series - Power Resistor

Power Resistor DST Series

A tubular ceramic resistor has a fixed number of windings and is wound with alloy wire as a resistance element. The staggering wound is made according to the desired resistance value, followed by the placement of the component mounts. It provides high starter power and is durable, is high temperature-resistant, dissipates heat well, has a low temperature coefficient that varies in direct proportion, and is suitable for application loads involving brief current surges. Due to the set number of windings on the ceramic form, the resistance value range is relatively low. Tolerance is $\pm 10\%$ and this product is available in various shapes or in resistance boxes.



Suitable for motor starters, load measurements, industrial machinery, electric distribution, instrumentation, and automation control installations, etc. For custom specifications, please contact us to discuss the details.

► Power Resistor DST Type 500W

Tubular Ceramic Starter

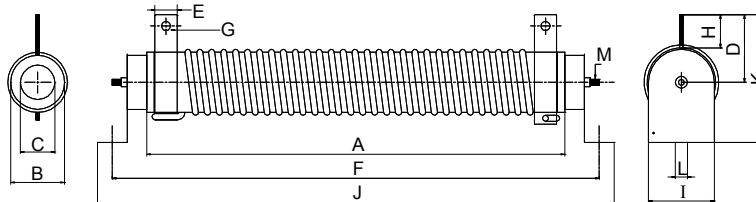

► Power Resistor DST Type 600W - 1000W

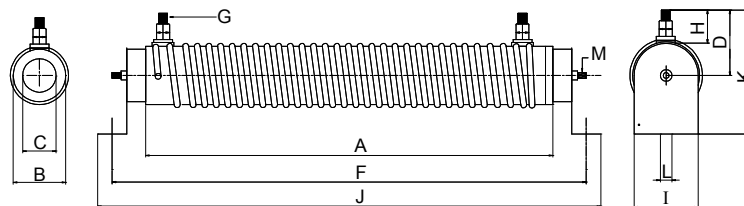

Wattage Rating	Dimensions(mm)												Resistance Range(Ω)	
	A	B	C	D	E	F	G	H	I	J	K	L		Weight
500W	280	40	23	45	15	326	6	22	34	346	85	8	970/g	3.5 Ω -7 Ω
600W	300	44	26	50	15	342	8	32	34	362	90	8	1277/g	0.5 Ω -3 Ω
1000W	420	48	30	56	15	470	8	32	40	490	105	9	1887/g	0.5 Ω -3 Ω

Notice: All dimensions might be changed or modified, please refer to last updating specification.

► How to Order

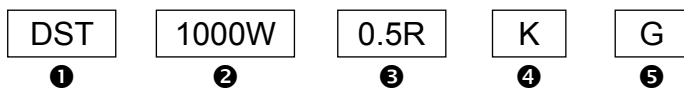

❶ Product Type: DST type

❷ Rated Wattage: 500W~1000W

❸ Resistance Value(Ω): (Ω)
Indicates Resistance Value in Units of Ohms.

❹ Resistance Tolerance: K($\pm 10\%$)

❺ Assembly Method

Code	Assembly Method
C	Clip Mount.
G	Horizontal Mount.
N	No Mount.
Z	Vertical Mount.



Power Resistors

Variable Resistors Power Type - FVR Series

Variable Resistors Power Type - A C-shaped ceramic is wound with copper or chromium-alloy wire as a resistance element. Except for the slide contact surface, the entire component is coated with a high-temperature, non-flammable resin. After cooling and drying, insulation is applied through a high-temperature process. Then, a centered rotating adjuster component is installed, which slides along the resistance element and varies the resistance to the desired value. The scope of the application includes educational modeling, load simulations, industrial machinery RPM adjustment, voltage and current adjustment, instruments, and automated control installations. For custom specifications, please contact us to discuss the details.



► Variable Resistor Power Type FVR Type 25W - 100W

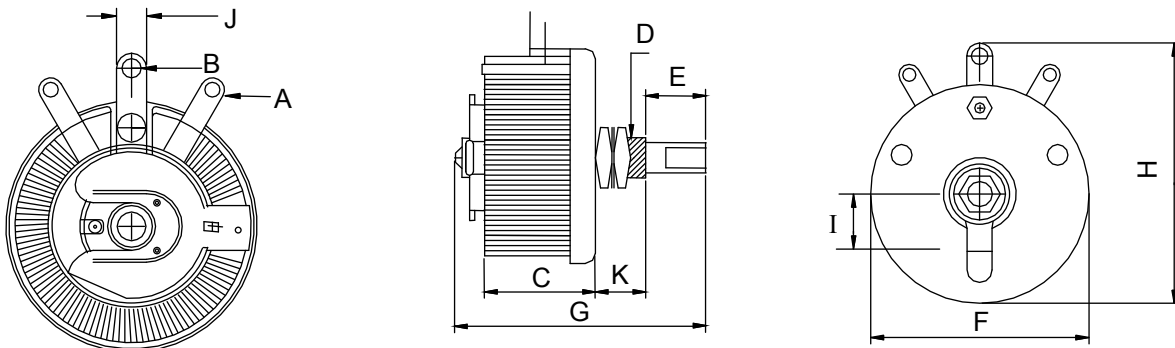

Wattage Rating	Dimensions(mm)											Resistance Range(Ω)	
	A	B	C	D	E	F	G	H	I	J	K		Weight
25W	2.5	3.2	22	3/8"	6x12	42	50	50	11	5	10	74/g	5 Ω -2.5K Ω
50W	4.2	4.2	28	3/8"	6x12	64	60	70	11	8	14	160/g	7 Ω -3.5K Ω
100W	4.2	4.2	42	3/8"	6x12	85	75	90	11	8	14	372/g	10 Ω -5K Ω

Notice: All dimensions might be changed or modified, please refer to last updating specification.

► Variable Resistor Power Type Performance Specifications

Test Item	Test Methods	Characteristics
Resistance tolerance	JIS-C-5261 5-1	Resistance tolerance $\pm 10\%$
Insulation resistance	JIS-C-5261 6-1 500VDC	100M Ω min
Dielectric withstanding voltage	JIS-C-5261 7-1 1000VDC 1 minute Between terminal and axis	Free of appearance or structural irregularity
Terminal strength	JIS-C-5261 6-5 3kg 30 seconds	Free of appearance or structural irregularity $\Delta R/R \leq \pm(2\%+0.1\Omega)$
Vibration	JIS-C-5261 6-6 1.5m/m 10 ~ 50 ~ 10 Hz/min X-Y-Z 2 hours each	Free of appearance or structural irregularity $\Delta R/R \leq \pm(2\%+0.1\Omega)$
Load life	JIS-C-5261 7-7	Free of appearance or structural irregularity $\Delta R/R \leq \pm(5\%+0.1\Omega)$
Full gyration angle	JIS-C-5261 6-1	300 \pm 5 $^\circ$ C
Flame retardation	100% - 600% rated wattage load	US UL-94 flame retardation test V-0 grade noncombustible
Remarks	1. Resistance and resistance tolerance were tested in-house with micro resistance meter. 2. Coating refers to UL-certified data provided by supplier.	



Power Resistors

▶ How to Order

FVR

❶

25W

❷

2.5KR

❸

K

❹

❶ Product Type: FVR type

❷ Rated Wattage: 25W~100W

❸ Resistance Value(Ω): (Ω)

Indicates Resistance
Value in Units of Ohms.

❹ Resistance Tolerance: K($\pm 10\%$)



Power Resistors

Aluminum Housed Power Resistor - AH Series

▶ Aluminum Housed Power Resistor Features

- High power rating , small size and ultra precision.
- Standard winding & non-inductive winding types.
- High stability , strong construction.

▶ Aluminum Housed Power Resistor General Specification:

- Wattage Range: 6 styles to choose ranging from 5 to 250 watts.
- Resistance Tolerance: 10%, 5%, 3%, 2%, 1%, 0.5%.
- Operating Temperature Range : -55% to +275°C
- Dielectric Strength: AH-5 AH-10 AH-25 1000V AH-50 1500V



▶ Aluminum Housed Power Resistor Standard Electrical Specification

Type	MIL	25°C Rated Power (W)		Resistance Range (Ω)			
	Type	Industry	Military	± 0.05%, ±0.1%	±0.25%	±0.5%	±1%,±5%,±10%
AH-5	RE60G	5	5	1.0~510Ω	0.5~1.5K	0.1~1.2K	0.10~3.32K
AH-5N	RE60N	5	5	1.0~100Ω	1.0~200Ω	1.0~860Ω	1.0~1.65K
AH-10	RE65G	10	10	1.0~1.2K	0.5-2.7K	0.1~2.7K	0.10~5.62K
AH-10N	RE65N	10	10	1.0~860Ω	1.0~1.2K	1.0~1.2K	1.0~2.8K
AH-25	RE70G	25	20	0.5~2.7K	0.1~3.9K	0.1~3.9K	0.10~12.1K
AH-25N	RE70N	25	20	1.0~1.2K	1.0~2.7K	1.0~2.7K	1.0~6.04K
AH-50	RE75G	50	30	0.5~3.9K	0.1~5.6K	0.1~5.6K	0.10~39.2K
AH-50N	RE75N	50	30	1.0~2.7K	1.0~3.9K	1.0~3.9K	1.0~19.6K
AH-100	RE77G	100	75	1.0~5.6K	0.1~8.2K	0.05~12K	0.05~29.4K
AH-100N	RE77N	100	75	1.0~3.9K	1.0~5.6K	1.0~5.6K	1.0~14.7K
AH-250	RE80G	250	120	0.1~12K	0.1~27K	0.1~27K	0.1~35.7K
AH-250N	RE80N	250	120	1.0~5.6K	1.0~8.2K	1.0~8.2K	1.0~17.4K

Notice: All dimensions might be changed or modified, please refer to last updating specification.

▶ Aluminum Housed Power Resistor Performance

Parameters	Test Conditions	Specifications
Short Time Over Load	5 × wattage rating-5sec.	Δ R±(0.5%+0.05Ω)Max.
Moisture Resistance	temp 40°C moisture 95% DC 100V 500Hr	Δ R±(0.5%+0.05Ω)Max.
Moisture Load Life	temp 40°C moisture 95% 1/10 × wattage rating (1.5Hr on-0.5Hr OFF)- Repeat 1000Hr	Δ R±(0.5%+0.05Ω)Max.
Load Life	Load Rating (chassis mounted) (1.5Hour on 0.5Hour OFF) Repeat 1000Hours	Δ R±(1.5%+0.05Ω)Max.
Vibration	10c/s~50c/s~10c/s(1Min)-2Hours each of paralleled and right angle	Δ R±(0.2%+0.05Ω)Max.
Heat Resistance	275°C 2Hours	Δ R±(0.5%+0.05Ω)Max.
Dielectric Strength	AH-5 AH-10 AH-25 1000V AH-50 1500V AH-100 AH-250 2500V	Δ R±(0.5%+0.05Ω)Max.
Insulation Resistance	Under the same test condition of Dielectric Strength, Load DC500V and measure the Insulation R.	1000MΩMin.
Terminal Strength	(1)Pull Test (30 sec Min) AH-5 1kg, AH-10 2.3kg, AH-25, AH-50 4.5kg (2)Torque Test(5~15sec) AH-100 27kg-cm, AH-250 36kg-cm	Δ R±(0.2%+0.05Ω)Max.



Power Resistors

► Surface Temperature Versus Power Load (on Chassis)

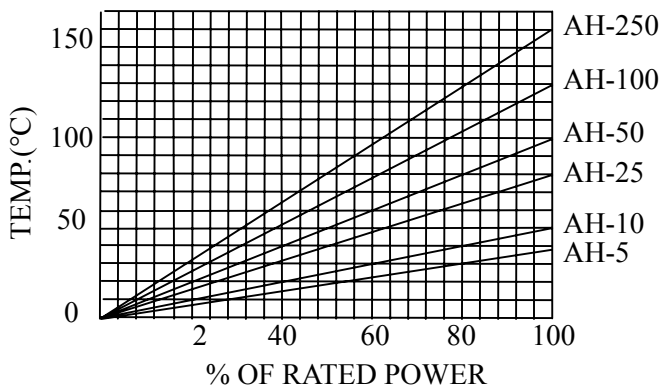

Derating

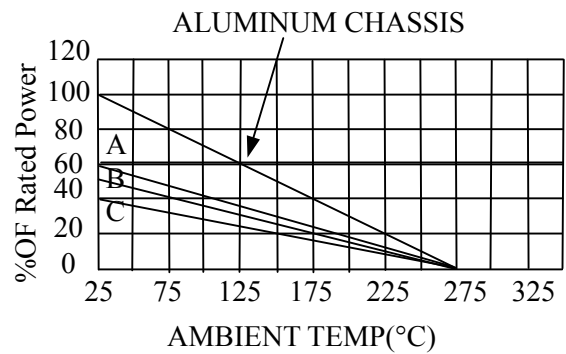

Derating is required to reduce chassis outting area and for high ambient temperatures.

Curves: A=5 & 10 watt unites, unmounted. B=25 watt units, unmounted. C=50,100 & 250 watt units, unmounted.

► Aluminum Housed Power Resistor Materials

Encapsulant : Silicone

End caps : Stainless steel

Core : Ceramic steatite or alumina

Housing : Aluminum with hard anodic coating

Element : Copper-nickel alloy, nickel-chrome alloy or manganese copper

Standard Terminals : 5~50W Tinned terminals , 100~250W Threaded terminals.

► Aluminum Housed Power Resistor Dimensions - AH-5, 10, 15, 50, AH-5N 10N, 15N, 50N

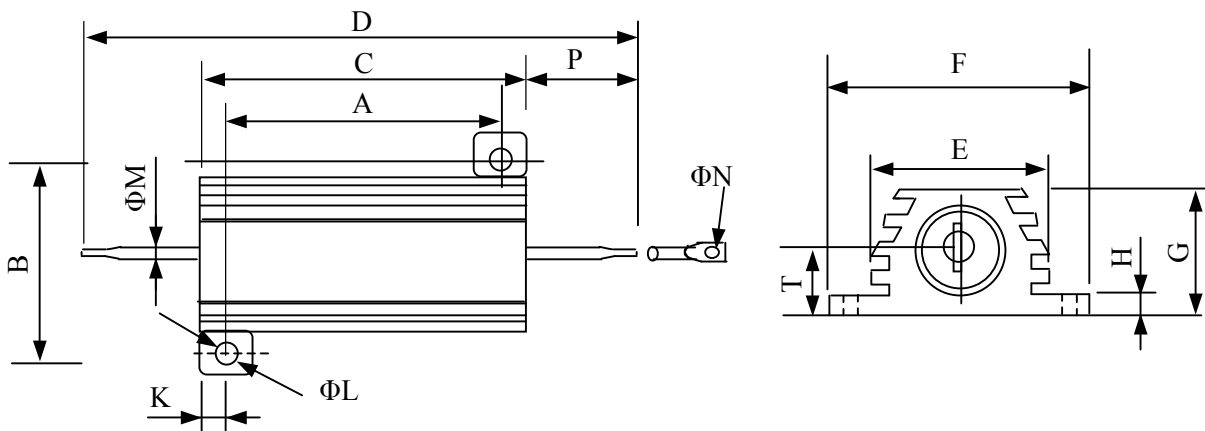

Type	Dimensions(mm)													
	A	B	C	D	E	F	G	H	J	K	L	M	N	P
AH-5	± 1.0	± 1.0	± 1.0	± 2.0	± 1.0	± 1.0	± 1.0	± 0.8	± 1.0	± 0.8	± 0.5	± 0.5	± 0.2	± 0.8
AH-10	11.2	125	15.2	28.6	8.5	16.4	8.1	1.7	3.8	2	2.4	1.5	1.3	6.7
AH-25	14.2	15.9	19	34.9	10.7	20.3	9.9	1.9	4.2	2.4	2.4	2	2.2	7.95
AH-25	18.2	19.8	27	49.2	14	27.4	13.9	1.9	5.9	4.4	3.2	1	2.2	11.1
AH-50	40	21.4	50	70.6	16	29	15.5	2.2	6.6	5	3.2	2	2.2	10.3

Notice: All dimensions might be changed or modified, please refer to last updating specification.



Power Resistors

▶ Aluminum Housed Power Resistor Dimensions - AH - 100, AH - 100N

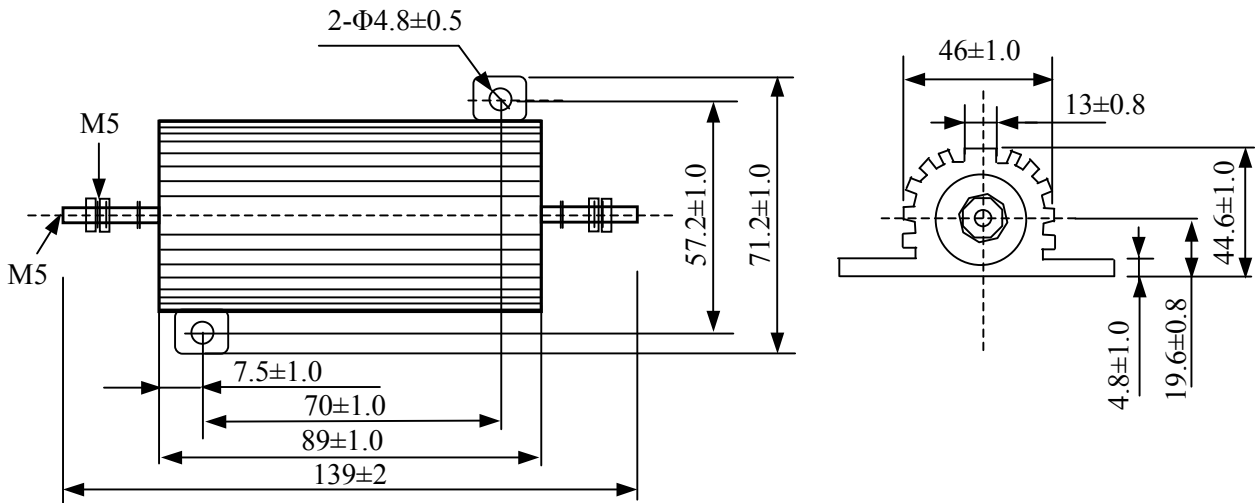

▶ Aluminum Housed Power Resistor Dimensions - AH - 250, AH - 250N

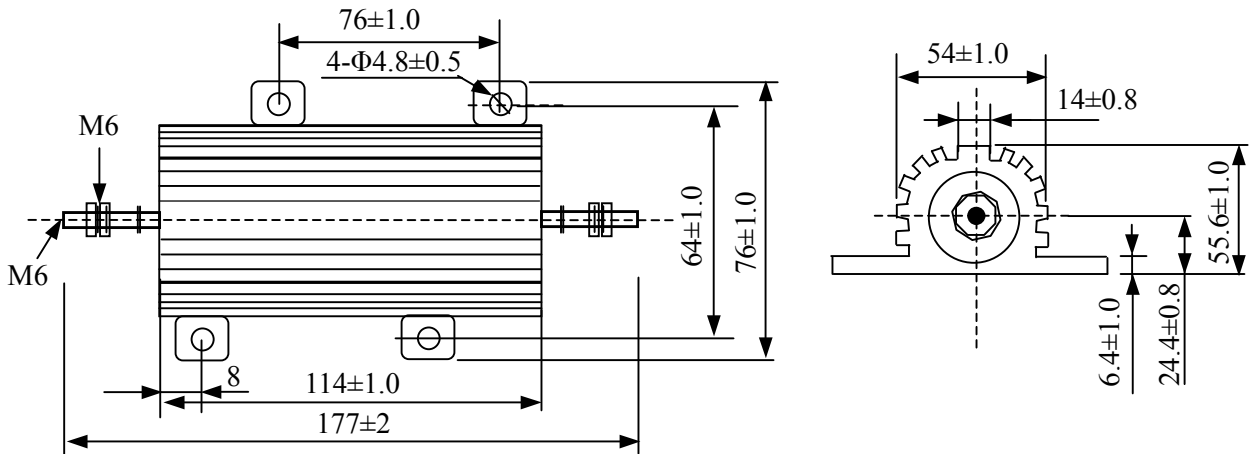

▶ How to Order

AH50 / AHN	50W	20R	D
①	②	③	④

- ① Product Type
- ② Rated Wattage
- ③ Resistance Value (Ω)
- ④ Resistance Tolerance



Power Resistors

▶ Aluminum Housed Power Resistor Standard Electrical Specification

Type	Wattage Rating (W)	Resistance Range (Ω)		Max. Working (V)		Proper heat sink (Aluminum chassis)
		AH Inductive	AHN Non-inductive	AH Inductive	AHN Non-inductive	
AH-25L	25	0.012~15K	0.02~5.5K	500	300	178*127*51*1t
AH-50L	50	0.01~40K	0.02~12K	1300	600	305*305*1.5t
AH-150NL	150	0.4~50K	0.12~25K	1900	1340	305*305*3t
AH-150ANL	150	0.4~50K	0.12~25K	1900	1340	305*305*3t

Notice: All dimensions might be changed or modified, please refer to last updating specification.

▶ Aluminum Housed Power Resistor Performance

Parameters	Test Conditions	Specifications
Short Time Over Load	5 × wattage rating-5 sec.	$\Delta R \pm (2\% + 0.1\Omega)$ Max.
Moisture Resistance	Temp 40°C moisture 95% DC 100V 500Hr	$\Delta R \pm (1\% + 0.1\Omega)$ Max.
Moisture Load Life	Temp 40°C moisture 95% 1/10 × wattage rating (1.5Hr on-0.5Hr OFF) - Repeat 200Hr	$\Delta R \pm (1\% + 0.1\Omega)$ Max.
Load Life	Load Rating (chassis mounted) (1.5Hour on 0.5Hour OFF) Repeat 1000Hours	$\Delta R \pm (5\% + 0.1\Omega)$ Max.
Vibration	10c/s~50c/s~10c/s (1Min) - 2Hour seach of paralleled and right angle	$\Delta R \pm (1\% + 0.05\Omega)$ Max.
Heat Resistance	260±5°C, 10±1Sec.	$\Delta R \pm (1\% + 0.05\Omega)$ Max.
Dielectric Strength	AH-5, AH-10, AH-25 1000V AH-50 1500V AH-100, AH-250 2000V	$\Delta R \pm (0.5\% + 0.05\Omega)$ Max.
Insulation Resistance	Under the same test condition of Dielectric Strength, Load DC500V and measure the Insulation R.	10M Ω Min.
Terminal Strength	(1) Pull Test (30 sec Min) AH-5 1kg, AH-10 2.3kg, AH-25, AH-50 4.5kg (2) Torque Test (5~15sec) AH-100 27kg-cm, AH-250 36kg-cm	$\Delta R \pm (0.2\% + 0.05\Omega)$ Max.

▶ Surface Temperature Versus Power Load (on Chassis)

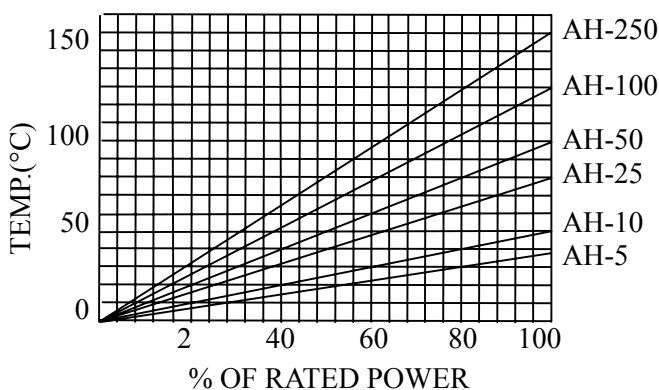

Deratning

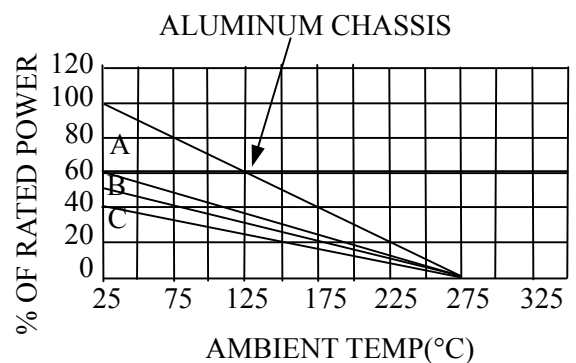

Derating is required to reduce chassis outting area and for high ambient temperatures.

Curves: A=5 & 10 watt units, unmounted. B=25 watt units, unmounted. C=50, 100 & 250 watt units, unmounted.



Power Resistors

▶ Aluminum Housed Power Resistor Materials

①	Encapsulant	Silicone			
	End caps	Stainless steel			
	Core	Ceramic steatite or aluminum			
	Housing	Aluminum with hard anodic coating			
	Element	Copper-nickel alloy, nickel-chrome alloy or manganese copper			
②	Wire (14AWG)	AH-25L	AH-50L	AH-150NL	AH-150ANL
		Length=160mm	Length=340mm	Length=500mm	Length=300mm
③	Terminals	LVA2-250, Cu (Nickel-plate), W7.5 × L10mm			

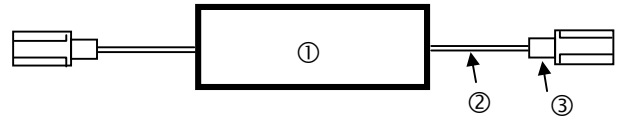

▶ Aluminum Housed Power Resistor Dimensions - AH-25L, AH-50L

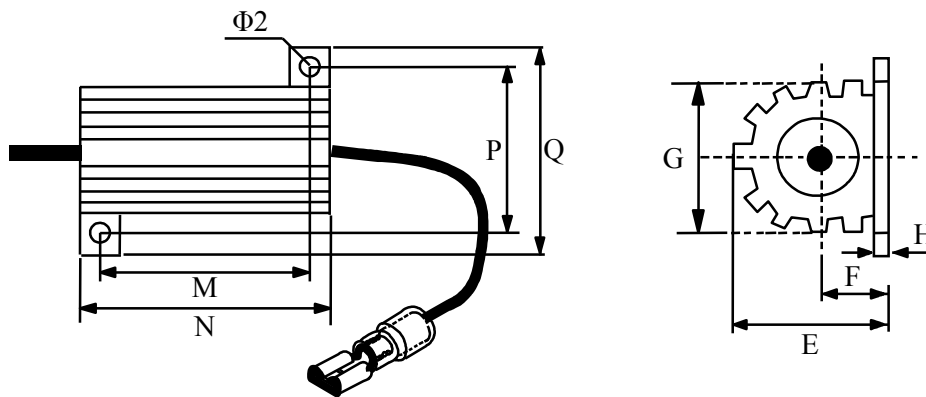

Type	Dimensions (Unit: mm)							
	E	F	G	H	M	N	P	Q
AH-25L	13	7	14.3	2	18.3	27	20	27
AH-50L	15.5	7.3	16	2	40	50	22	29

▶ Aluminum Housed Power Resistor Dimensions - AH-150NL, AH-150ANL

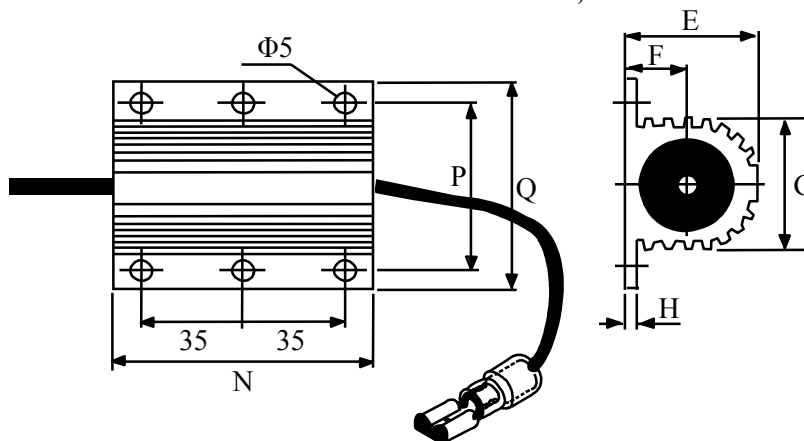

Type	Dimensions (Unit: mm)						
	E	F	G	H	N	P	Q
AH-150NL	45	9.6	46	5	92	57	72
AH-150ANL	26	11.5	27	3.5	97	37	48

Notice: All dimensions might be changed or modified, please refer to last updating specification.



Power Resistors

▶ Aluminum Housed Power Resistor LVA250 Dimensions

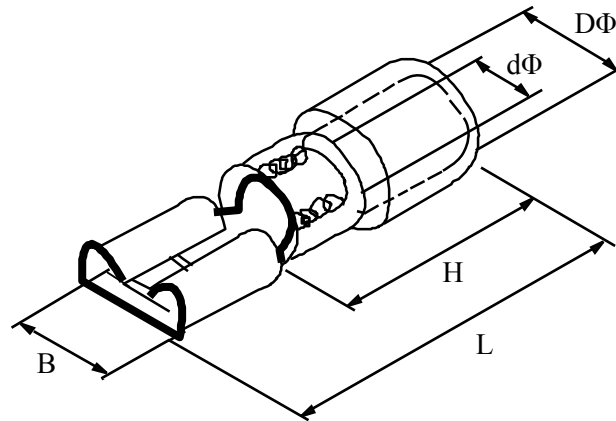

Suitable for 14~16AWG		I _{max} =15A		Unit: mm		Tol.: ±0.2mm	
ITEM	NEMA-TAB	Thickness	B	dΦ	DΦ	L	H
LVA 2-250	0.8 × 6.35	0.4	7.4	2.3	4.3	21.0	10.0

▶ How to Order

AH	50W	L340	14AWG	0R2	K
①	②	③	④	⑤	⑥

- ① Product type : AH(-25L) ; AH(-50L) ; AH(-150NL);AH(-150ANL)
- ② Rated Power : 25W ; 50W ; 150W
- ③ Wire Length (min.) : L160 ; L340 ; L500 ; L300
- ④ Wire Type : 14AWG
- ⑤ Resistance Value (Ω): 12K1 ; 0R2 ; 10KR
- ⑥ Resistance Tolerance (%) : K(±10%)



Power Resistors

AL Series Power Resistor

Power Resistor An aluminum encased consists of an alloy metal coil-type resistance element assembled into an aluminum enclosure. Following high-temperature anodization, the enclosure is filled with a special non-flammable cement paste and after hardening, insulation is applied through a high-temperature process. Since the component is embedded in the heat-proof cement, it is not affected by external mechanical force, dusty environments, and extreme duty. It is durable, vibration-proof, dissipates heat well, and has a low temperature coefficient, with resistance varying in direct proportion. Supporting a flexible range of applications, the product is easy to utilize and install. Applications include industrial machinery, load testing, electric power distribution, instruments, and automated control installations.



For custom specifications, please contact us to discuss the details.

► Power Resistor Performance Specifications

Test Item	Test Methods	Characteristics
Resistance tolerance	JIS-C-5202 5-1	Resistance Nominal Tolerance $1 \leq R$ $1 > R$ $\pm 5\%(J) \pm 10\%(K)$
Temperature coefficient	JIS-C-5202 5-2	$\pm 400 \text{PPM}/^\circ\text{C MAX}$
Power rating load	JIS-C-5202 5-4	$\Delta R/R \leq \pm(0.5\% + 0.1\Omega)$ Surface temperature up to 350°C MAX
Short-term overload	JIS-C-5202 5-5 1000% rated power 5 seconds	Free of appearance or structural irregularity $\Delta R/R \leq \pm(2\% + 0.1\Omega)$
Insulation resistance	JIS-C-5202 5-6 1000VDC	100M Ω min
Dielectric withstanding voltage	JIS-C-5202 5-7 2000VDC 1 minute	Free of appearance or structural irregularity $\Delta R/R \leq \pm(0.1\% + 0.05\Omega)$
Terminal strength	JIS-C-5202 6-1 8kg 30 seconds	Free of appearance or structural irregularity
Resistor strength	JIS-C-5202 6-2 30kg 30 seconds	Free of appearance or structural irregularity
Vibration	JIS-C-5202 6-3 1.5m/m 10 ~ 50 ~ 10 Hz/min X-Y-Z 2 hours each	Free of appearance or structural irregularity Surface coating crack $\Delta R/R \leq \pm(1\% + 0.05\Omega)$
Thermal shock	JIS-C-5202 7-3 Room temp 30 minutes ON- 55°C 15 minutes OFF	Resistor free of structural irregularity $\Delta R/R \leq \pm(2\% + 0.1\Omega)$
Humidity	JIS-C-5202 7-5 40°C 90%RH 240 hours	Free of appearance or structural irregularity Surface coating crack $\Delta R/R \leq \pm(3\% + 0.1\Omega)$
Load life	JIS-C-5202 7-10 90 minutes ON - 30 minutes OFF 500 hours	Free of appearance or structural irregularity Surface coating crack $\Delta R/R \leq \pm(3\% + 0.1\Omega)$
Flame retardation	JIS-C-5202 7-13-3-2 100% - 600% rated power load	US UL-94 flame retardation test V-0 grade noncombustible
Remarks	1. Resistance and resistance tolerance were tested in-house with micro resistance meter. 2. Resistor coating refers to UL-certified data provided by supplier	



Power Resistors

▶ ASQ Type Power Resistor - High Voltage, Aluminum Encased

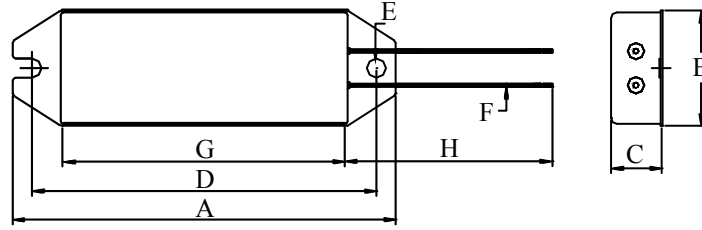

Power Rating	Dimensions(mm)									Resistance Range(Ω)
	A	B	C	D	E	F	G	H	Weight	
60W	100	30	13	90	4.5	0.75mm ²	75	400	66/g	1-10K Ω
80W	150	34	21	140	5	0.75mm ²	125	400	170/g	1-10K Ω
120W	182	42	21	172	6	0.75mm ²	150	400	175/g	1-10K Ω

▶ Power Resistor ASH Type - High Voltage, Aluminum Encased

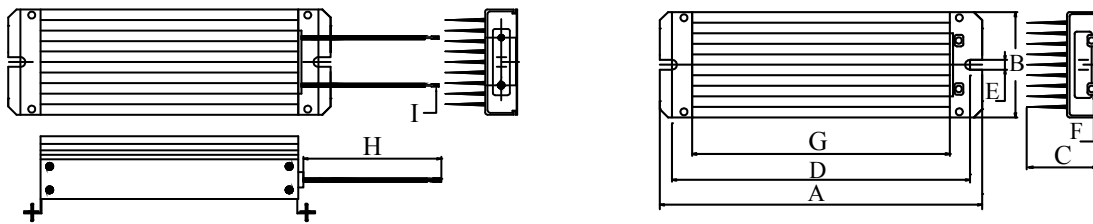

Power Rating	Dimensions(mm)										Resistance Range(Ω)
	A	B	C	D	E	F	G	H	I	Weight	
200W	200	65	45	185	6	M5×8mm	160	300	2mm ²	725/g	1-10K Ω
300W	280	65	45	265	6	M5×8mm	240	300	2mm ²	1050/g	1-10K Ω
400W	360	65	45	345	6	M5×8mm	320	300	2mm ²	1295/g	1-10K Ω
500W	440	65	45	425	6	M5×8mm	400	300	2mm ²	1650/g	1-10K Ω
600W	520	65	45	505	6	M5×8mm	480	300	2mm ²	1935/g	1-10K Ω

▶ Power Resistor ASZ Type - High Voltage, Aluminum Encased

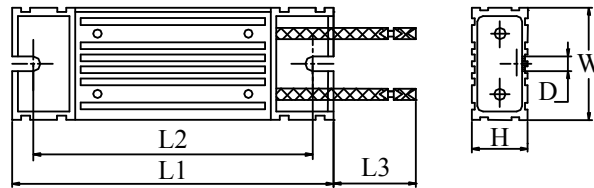

Power Rating	Dimensions (mm)							Resistance Range (Ω)
	W±1	H±1	L±2	L2±2	D±0.5	L3±10	Weight	
60W	40	20	115	100	5.2	200	165/g	2-2K Ω
80W	40	20	140	125	5.2	200	190/g	2-2.5K Ω
100W	40	20	165	150	5.2	200	225/g	2-3K Ω
120W	40	20	190	175	5.2	200	275/g	3-4K Ω
150W	40	20	215	200	5.2	200	310/g	3-5K Ω
200W	60	30	165	150	5.2	300	500/g	3-6K Ω
300W	60	30	215	200	5.2	300	675/g	5-7K Ω
400W	60	30	265	250	5.2	300	850/g	5-8K Ω
600W	60	30	335	320	5.2	300	1070/g	5-9K Ω
800W	60	30	400	385	5.2	300	1250/g	5-10K Ω
1500W	130	80	485	440			4300/g	15-1K Ω

Notice: All dimensions might be changed or modified, please refer to last updating specification.



Power Resistors

▶ ASZ Type Power Resistor - 1500W - High Voltage, Aluminum Encased

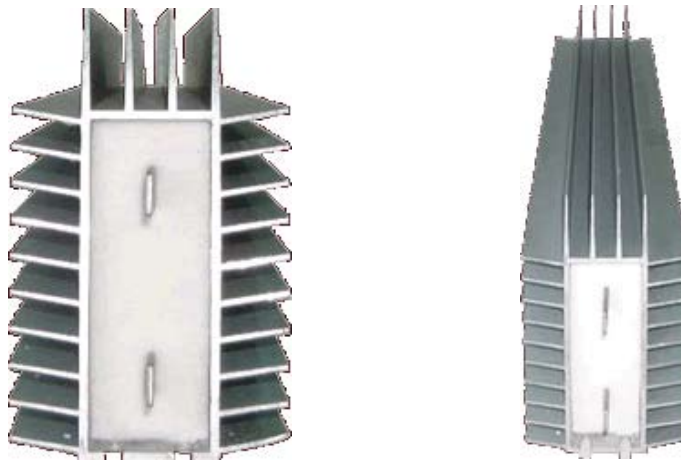
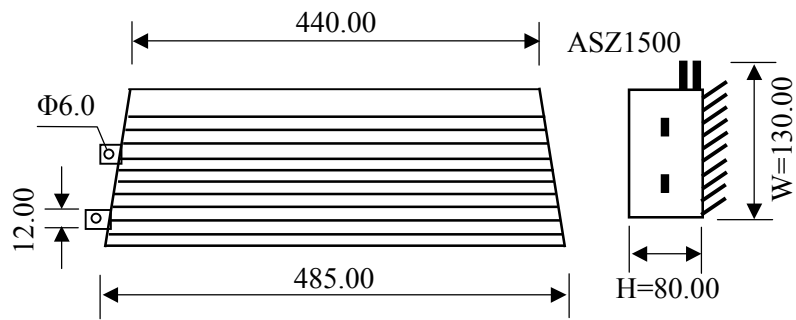

▶ How to Order



- ❶ Product Type : ASQ type ; ASH type ; ASZ type
- ❷ Rated Power : 60W~120W ; 200W~600W ; 60W~800W
- ❸ Resistance Value (Ω) : (Ω) Indicates resistance value in units of ohms.
- ❹ Resistance Tolerance :

Code	Resistance Tolerance
J	($\pm 5\%$)
K	($\pm 10\%$)



Power Resistors

High Power Resistors - DQ Series

High Power Resistor - Nonflammable Wave-Shape Ribbon Wirewound DQ Series

A tubular ceramic has two terminals, and is wound with a resistance element consisting of a wave-shaped alloy ribbon. Non-flammable resin insulation is applied after cooling and drying through a temperature process and then the component mounts are attached. The resistance value range is relatively low due to alloy material limitations; see the DR series if upper resistance values are required.

This product supports the use of numerous taps, has low impedance, and can be fabricated in various shapes to support a wide range of applications. The DQ series is suitable for educational modeling

applications, load testing, industrial machinery, electric power distribution, instruments, automation control installations, etc. For custom specifications, please contact us to discuss the details.

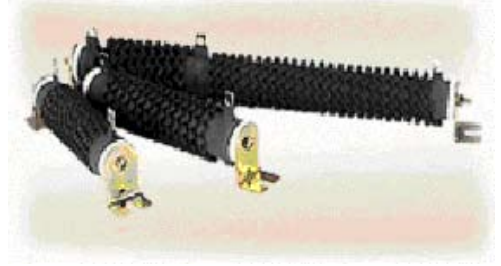

► High Power Resistor DQR Type 75W - 2000W

Tubular Ceramic, Wave, Low Inductive

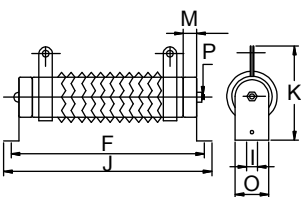
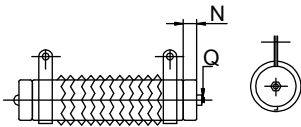
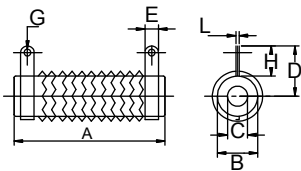

Wattage Rating	Dimensions(mm)														Resistance Range(Ω)
	A	B	C	D	E	F	G	H	I	J	K	L	M	O	
75W	110	25	16	30	8	150	5	18	6	166	58	1.2	6	27	0.1~8 Ω
90W	90	28	18	32	8	130	5	19	6	146	60	1.2	6	27	0.1~9 Ω
120W	110	28	18	32	8	150	5	19	6	166	60	1.2	6	27	0.1~12 Ω
150W	140	28	18	32	8	180	5	19	6	196	60	1.2	6	27	0.1~15 Ω
180W	160	28	18	32	8	200	5	19	6	216	60	1.2	6	27	0.1~18 Ω
225W	195	28	18	32	8	235	5	19	6	251	60	1.2	6	27	0.1~23 Ω
240W	185	35	24	36	10	225	5	19	8	245	76	1.6	6	34	0.1~24 Ω
300W	210	35	24	36	10	250	5	19	8	274	76	1.6	6	34	0.3~30 Ω
375W	210	40	25	38	12	250	5	20	8	274	78	1.6	6	34	0.3~38 Ω
450W	260	40	25	38	12	300	5	20	8	320	78	1.6	6	34	0.3~45 Ω
600W	330	40	25	38	12	370	5	20	8	395	78	1.6	6	34	0.3~60 Ω
750W	330	50	35	50	12	380	6	25	9	400	100	1.6	8	40	0.3~75 Ω
900W	400	50	35	50	12	450	6	25	9	470	100	1.6	8	40	0.3~90 Ω
1000W	460	50	35	50	12	510	6	25	9	530	100	1.6	8	40	0.5~100 Ω
1200W	460	60	40	55	15	515	6	30	10	535	110	1.6	10	50	0.5~120 Ω
1500W	540	60	40	55	15	595	6	30	10	615	110	1.6	10	50	0.5~150 Ω
2000W	650	65	42	62	15	702	6	30	10	722	115	1.6	10	50	0.5~200 Ω

Notice: All dimensions might be changed or modified, please refer to last updating specification.



Power Resistors

► High Power Resistor DQN Type 75W - 2000W

Tubular Ceramic, Wave, Low Inductive

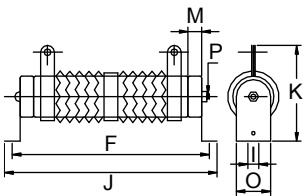
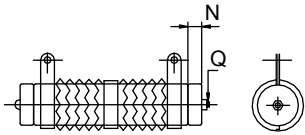
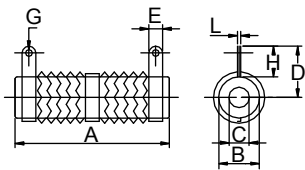

Wattage Rating	Dimensions(mm)														Resistance Range(Ω)
	A	B	C	D	E	F	G	H	I	J	K	L	M	O	
75W	110	25	16	30	8	150	5	18	6	166	58	1.2	6	27	0.1~8 Ω
90W	90	28	18	32	8	130	5	19	6	146	60	1.2	6	27	0.1~9 Ω
120W	110	28	18	32	8	150	5	19	6	166	60	1.2	6	27	0.1~12 Ω
150W	140	28	18	32	8	180	5	19	6	196	60	1.2	6	27	0.1~15 Ω
180W	160	28	18	32	8	200	5	19	6	216	60	1.2	6	27	0.1~18 Ω
225W	195	28	18	32	8	235	5	19	6	251	60	1.2	6	27	0.1~23 Ω
240W	185	35	24	36	10	225	5	19	8	245	76	1.6	6	34	0.1~24 Ω
300W	210	35	24	36	10	250	5	19	8	274	76	1.6	6	34	0.3~30 Ω
375W	210	40	25	38	12	250	5	20	8	274	78	1.6	6	34	0.3~38 Ω
450W	260	40	25	38	12	300	5	20	8	320	78	1.6	6	34	0.3~45 Ω
600W	330	40	25	38	12	370	5	20	8	395	78	1.6	6	34	0.3~60 Ω
750W	330	50	35	50	12	380	6	25	9	400	100	1.6	8	40	0.3~75 Ω
900W	400	50	35	50	12	450	6	25	9	470	100	1.6	8	40	0.3~90 Ω
1000W	460	50	35	50	12	510	6	25	9	530	100	1.6	8	40	0.5~100 Ω
1200W	460	60	40	55	15	515	6	30	10	535	110	1.6	10	50	0.5~120 Ω
1500W	540	60	40	55	15	595	6	30	10	615	110	1.6	10	50	0.5~150 Ω
2000W	650	65	42	62	15	702	6	30	10	722	115	1.6	10	50	0.5~200 Ω

Notice: All dimensions might be changed or modified, please refer to last updating specification.

► High Power Resistor DQS Type 75W - 2000W

Tubular Ceramic, Wave, Variable

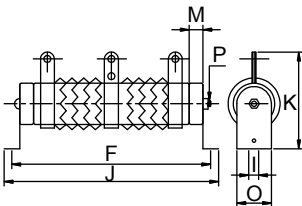
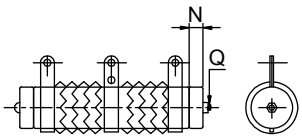
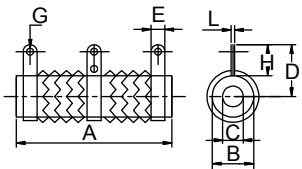

Wattage Rating	Dimensions(mm)														Resistance Range(Ω)
	A	B	C	D	E	F	G	H	I	J	K	L	M	O	
75W	110	25	16	30	8	150	5	18	6	166	58	1.2	6	27	0.1~8 Ω
90W	90	28	18	32	8	130	5	19	6	146	60	1.2	6	27	0.1~9 Ω
120W	110	28	18	32	8	150	5	19	6	166	60	1.2	6	27	0.1~12 Ω
150W	140	28	18	32	8	180	5	19	6	196	60	1.2	6	27	0.1~15 Ω
180W	160	28	18	32	8	200	5	19	6	216	60	1.2	6	27	0.1~18 Ω
225W	195	28	18	32	8	235	5	19	6	251	60	1.2	6	27	0.1~23 Ω
240W	185	35	24	36	10	225	5	19	8	245	76	1.6	6	34	0.1~24 Ω
300W	210	35	24	36	10	250	5	19	8	274	76	1.6	6	34	0.3~30 Ω
375W	210	40	25	38	12	250	5	20	8	274	78	1.6	6	34	0.3~38 Ω
450W	260	40	25	38	12	300	5	20	8	320	78	1.6	6	34	0.3~45 Ω
600W	330	40	25	38	12	370	5	20	8	395	78	1.6	6	34	0.3~60 Ω
750W	330	50	35	50	12	380	6	25	9	400	100	1.6	8	40	0.3~75 Ω
900W	400	50	35	50	12	450	6	25	9	470	100	1.6	8	40	0.3~90 Ω
1000W	460	50	35	50	12	510	6	25	9	530	100	1.6	8	40	0.5~100 Ω
1200W	460	60	40	55	15	515	6	30	10	535	110	1.6	10	50	0.5~120 Ω
1500W	540	60	40	55	15	595	6	30	10	615	110	1.6	10	50	0.5~150 Ω
2000W	650	65	42	62	15	702	6	30	10	722	115	1.6	10	50	0.5~200 Ω

Notice: All dimensions might be changed or modified, please refer to last updating specification.



Power Resistors

► High Power Resistor Performance Specification

TEST ITEM	TEST METHODS	CHARACTERISTICS
Resistance tolerance	JIS-C-5202 5-1	Resistance Nominal Tolerance 1≤R 1>R ±5%(J) ±10%(K)
Temperature coefficient	JIS-C-5202 5-2	±400PPM/°C MAX
Load rating	JIS-C-5202 5-4	ΔR/R≤±(0.5%+0.1Ω) Surface temperature up 350°C MAX
Short-term overload	JIS-C-5202 5-5 500% rated wattage 5 seconds	Free of appearance or structural irregularity ΔR/R≤±(2%+0.1Ω)
Insulation resistance	JIS-C-5202 5-6 500VDC	100MΩ min
Dielectric withstanding voltage	JIS-C-5202 5-7 1000VDC 1 minute Between terminal and anchor stand	Free of appearance or structural irregularity ΔR/R≤±(0.1%+0.05Ω)
Terminal strength	JIS-C-5202 6-1 8kg 30 seconds	Free of appearance or structural irregularity
Vibration	JIS-C-5202 6-3; 1.5m/m 10 ~ 50 ~ 10 Hz/min X-Y-Z 2 hours each	Free of appearance or structural irregularity Surface coating crack ΔR/R≤±(1%+0.05Ω)
Thermal shock	JIS-C-5202 7-3 Room temp 30 minutes ON-55°C 15 minutes OFF	Free of structural irregularity ΔR/R≤±(1%+0.05Ω)
Humidity	JIS-C-5202 7-5 40°C 90%RH 240 hours	Free of appearance or structural irregularity Surface coating crack ΔR/R≤±(3%+0.1Ω)
Load life	JIS-C-5202 7-10 90 minutes ON - 30 minutes OFF 500 hours	Free of appearance or structural irregularity Surface coating crack ΔR/R≤±(5%+0.1Ω)
Flame retardation	JIS-C-5202 7-13-3-2 100% - 600% rated wattage load	US UL-94 flame retardation test V-0 grade noncombustible
REMARKS:	1. Resistance and resistance tolerance were tested in-house with micro resistance meter. 2. Coating refers to UL-certified data provided by supplier	

► How to Order

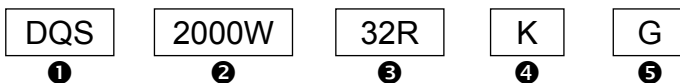

❶ Product Type: DQR type
DQN type
DQS type

❷ Rated Wattage: 75W~2000W
75W~2000W
75W~2000W

❸ Resistance Value(Ω): (Ω)
Indicates Resistance
Value in Units of Ohms.

❹ Resistance Tolerance

Code	Resistance Tolerance
H	±3%
J	±5%
K	±10%

❺ Assembly Method

Code	Assembly Method
C	Clip Mount.
G	Horizontal Mount.
N	No Mount.
Z	Vertical Mount.



Power Resistors

Wirewound Power Resistors - ZZR Series

Wirewound Power Resistor - A flat tubular ceramic has two terminals and is wound with either copper wire or chromium alloy wire as a resistance element. It is coated with a high-temperature non-flammable resin. When cooled and dried, it is encapsulated in insulation through a high-temperature process before the final installation of the component mounts. It is mainly utilized for industrial installations where height is limited. Features excellent windings, taps adding, low impedance, and PC board insertable. These resistors are suitable for educational modeling applications, load testing, industrial machinery, electric power distribution, instruments, automation control installations, etc. For custom specifications, please contact us to discuss the details.



► Wirewound Power Resistor ZZR Type 40W ~ 300W

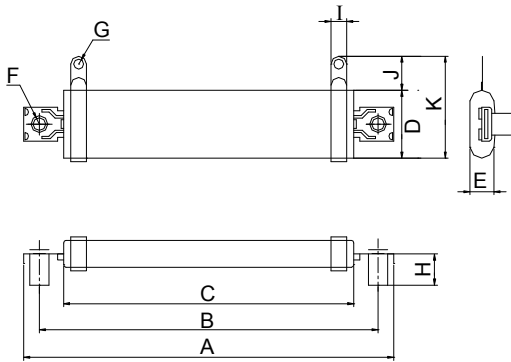

Wattage Rating	Dimensions(mm)											Resistance Range(Ω)
	A	B	C	D	E	F	G	H	I	J	K	
40W	83	70	50	28	11	5.2	4.1	13	6.5	12	42	0.1~5K Ω
55W	123	110	90	28	11	5.2	4.1	13	6.5	12	42	0.1~6K Ω
70W	153	140	120	28	11	5.2	4.1	13	6.5	12	42	0.1~7K Ω
95W	183	170	150	28	11	5.2	4.1	13	6.5	12	42	0.1~10K Ω
100W	193	180	160	28	11	5.2	4.1	13	6.5	12	42	0.1~12K Ω
120W	218	205	185	28	11	5.2	4.1	13	9	12	42	0.1~15K Ω
150W	218	205	185	35	11	5.2	5.2	13	9	13	48	0.1~18K Ω
200W	243	230	210	35	11	5.2	5.2	13	9	13	48	0.1~25K Ω
250W	287	274	254	35	11	5.2	5.2	13	9	13	48	0.1~30K Ω
300W	333	320	300	35	11	5.2	5.2	13	9	13	48	0.1~35K Ω

► Wirewound Power Resistor ZQR Type 60W ~ 450W

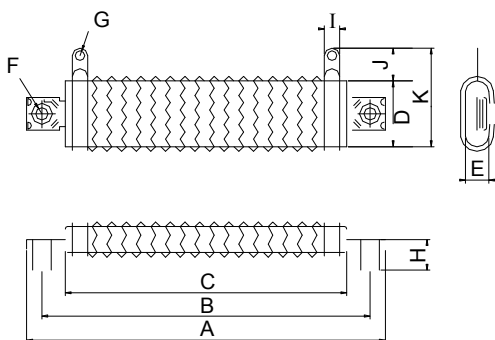

Wattage Rating	Dimensions(mm)											Resistance Range(Ω)
	A	B	C	D	E	F	G	H	I	J	K	
60W	83	70	50	28	11	5.2	4.1	13	6.5	12	42	1~4 Ω
80W	123	110	90	28	11	5.2	4.1	13	6.5	12	42	1~5 Ω
100W	153	140	120	28	11	5.2	4.1	13	6.5	12	42	1~7 Ω
140W	183	170	150	28	11	5.2	4.1	13	6.5	12	42	1~9 Ω
150W	193	180	160	28	11	5.2	4.1	13	6.5	12	42	1~10 Ω
180W	218	205	185	28	11	5.2	4.1	13	9	12	42	1~12 Ω
225W	218	205	185	35	11	5.2	5.2	13	9	13	48	1~15 Ω
300W	243	230	210	35	11	5.2	5.2	13	9	13	48	1~20 Ω
375W	287	274	254	35	11	5.2	5.2	13	9	13	48	1~25 Ω
450W	333	320	300	35	11	5.2	5.2	13	9	13	48	1~30 Ω

Notice: All dimensions might be changed or modified, please refer to last updating specification.





Power Resistors

► How to Order

ZZR

❶

55W

❷

10R

❸

J

❹

❶ Product Type: ZZR type
ZQR type

❷ Rated Wattage: 40W~300W
60W~450W

❸ Resistance Value(Ω): (Ω)
Indicates Resistance
Value in Units of Ohms.

❹ Resistance Tolerance

Code	Resistance Tolerance
H	$\pm 3\%$
J	$\pm 5\%$
K	$\pm 10\%$





Power Resistors

Wirewound Power Resistor - ZQN Series

► Wirewound Power Resistor ZNR Type 40W ~ 450W

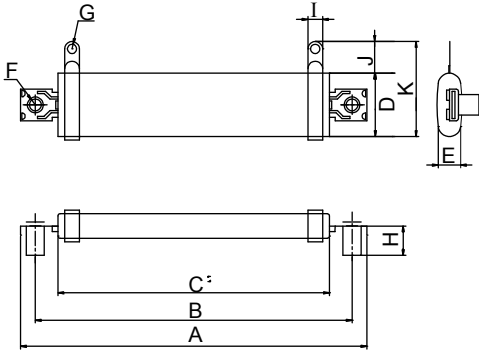

Wattage Rating	Dimensions(mm)											Resistance Range(Ω)
	A	B	C	D	E	F	G	H	I	J	K	
40W	83	70	50	28	11	5.2	4.1	13	6.5	12	42	0.1~2KΩ
55W	123	110	90	28	11	5.2	4.1	13	6.5	12	42	0.1~2.5KΩ
70W	153	140	120	28	11	5.2	4.1	13	6.5	12	42	0.1~3KΩ
95W	183	170	150	28	11	5.2	4.1	13	6.5	12	42	0.1~4.5KΩ
100W	193	180	160	28	11	5.2	4.1	13	6.5	12	42	0.1~5.5KΩ
120W	218	205	185	28	11	5.2	4.1	13	9	12	42	0.1~7KΩ
150W	218	205	185	35	11	5.2	5.2	13	9	13	48	0.1~8.5KΩ
200W	243	230	210	35	11	5.2	5.2	13	9	13	48	0.1~12KΩ
250W	287	274	254	35	11	5.2	5.2	13	9	13	48	0.1~14KΩ
300W	333	320	300	35	11	5.2	5.2	13	9	13	48	0.1~16KΩ

► Wirewound Power Resistor ZQN Type 60W ~ 450W

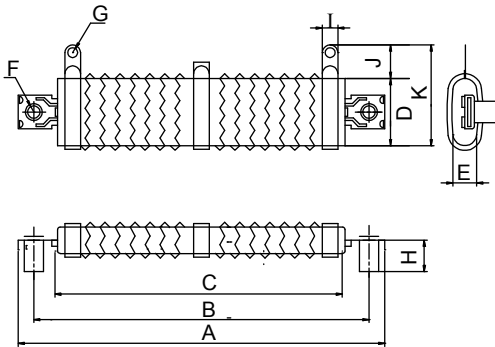

Wattage Rating	Dimensions(mm)											Resistance Range(Ω)
	A	B	C	D	E	F	G	H	I	J	K	
60W	83	70	50	28	11	5.2	4.1	13	6.5	12	42	1~4Ω
80W	123	110	90	28	11	5.2	4.1	13	6.5	12	42	1~5Ω
100W	153	140	120	28	11	5.2	4.1	13	6.5	12	42	1~7Ω
140W	183	170	150	28	11	5.2	4.1	13	6.5	12	42	1~9Ω
150W	193	180	160	28	11	5.2	4.1	13	6.5	12	42	1~10Ω
180W	218	205	185	28	11	5.2	4.1	13	9	12	42	1~12Ω
225W	218	205	185	35	11	5.2	5.2	13	9	13	48	1~15Ω
300W	243	230	210	35	11	5.2	5.2	13	9	13	48	1~20Ω
375W	287	274	254	35	11	5.2	5.2	13	9	13	48	1~25Ω
450W	333	320	300	35	11	5.2	5.2	13	9	13	48	1~30Ω

Notice: All dimensions might be changed or modified, please refer to last updating specification.

► How to Order



① Product Type: ZNR type
ZQR type

② Rated Wattage: 40W~300W
60W~450W

③ Resistance Value(Ω): (Ω)
Indicates Resistance
Value in Units of Ohms.

④ Resistance Tolerance

Code	Resistance Tolerance
H	±3%
J	±5%
K	±10%



Power Resistors

High Current Oval Edge-wound Power Resistor - DOE Series

The choice when conditions demand top-notch performance, these resistors are commonly used for dynamic braking on Transit applications. Built to perform in rugged environments, they feature corrosion resistant stainless steel insulator supports, solid nickel terminals, and special electroless nickel-plated solid copper terminal supports. The resistance element is made of a stainless steel resistance alloy. Terminals are welded or silver brazed to the oval, spiral edge-wound resistance element. Toothed ceramic insulators isolate the resistance element from the center support. Ceramic end bushings insulate the center support from the mountings. Order individual replacement units or entire grids with various mounting configurations. Contact us with your specific needs.



► Power Resistors - DOE Type 550W - 3250W Standard Electrical Specification

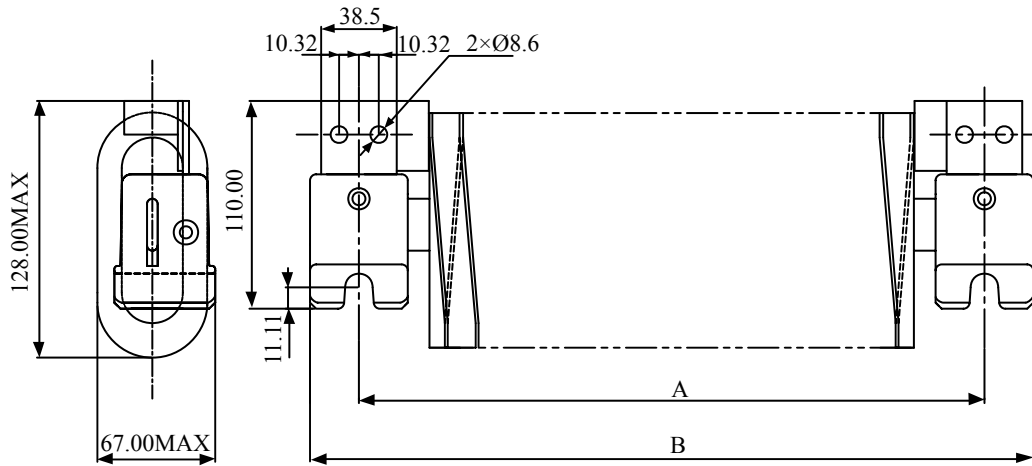

Power Rating	A (mm)	B (mm)	Resistance Value Range
550W	244.5	295	1R~20R
900W	335	385.5	
1200W	419	470	
1500W	505	556	
1800W	588	638	
3250W	410	465	



Power Resistors

► High Current Oval Edge-wound Power Resistor Performance Specification

TEST ITEM	TEST METHODS	CHARACTERISTICS
Resistance tolerance	JIS-C-5202 5-1	Resistance Nominal Tolerance $\pm 10\%$ (K)
Temperature coefficient	JIS-C-5202 5-2	$\pm 300\text{ppm}/^\circ\text{C}$ max.
Power rating load	JIS-C-5202 5-4	$R/R \leq \pm(1\%+0.1\Omega)$ Surface temperature up 350°C max.
Dielectric withstanding voltage	JIS-C-5202 5-7 2000VDC 1 minute Between terminal and anchor stand	Free of appearance or structural irregularity $\Delta R/R \leq \pm(1\%+0.1\Omega)$
Terminal strength	JIS-C-5202 6-1 500N 30 seconds	Free of appearance or structural irregularity
Insulation resistance	JIS-C-5202 5-6 500VDC	100M Ω min
Short-term overload	JIS-C-5202 5-5 1000% rated power 5 seconds	Free of appearance or structural irregularity $\Delta R/R \leq \pm(2\%+0.1\Omega)$
Vibration	JIS-C-5202 6-3 490m/s ² 11ms	Free of appearance or structural irregularity Surface coating crack $\Delta R/R \leq \pm(2\%+0.1\Omega)$
Remarks	Resistance and resistance tolerance were tested in-house with micro resistance meter.	

► How to Order

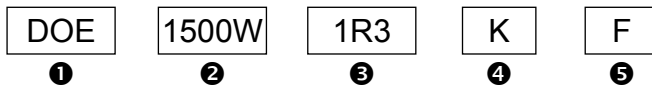

- ① Product Type: DOE type
- ② Rated Power: 1500W
- ③ Resistance Value(Ω): 1R3
- ④ Resistance Tolerance ($\pm 10\%$): K
- ⑤ Lead Free: F



Power Resistors

Power Resistors Assembly Method

► Power Resistors Assembly Method

N - No mount

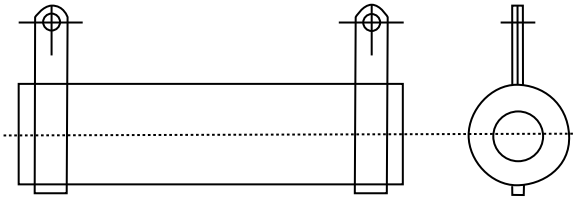

G - Horizontal mount

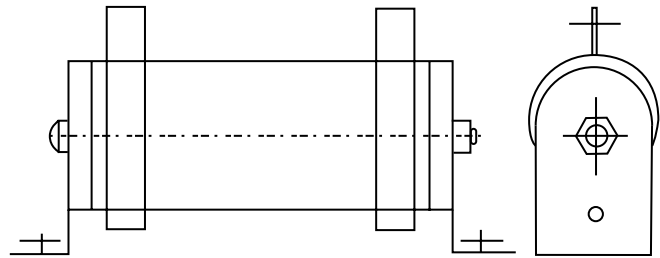

Z - Vertical mount

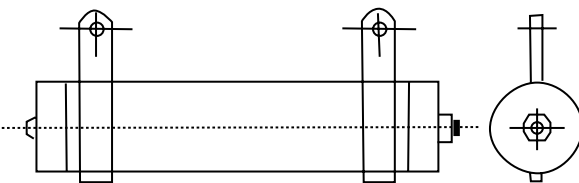

C - Clip mount

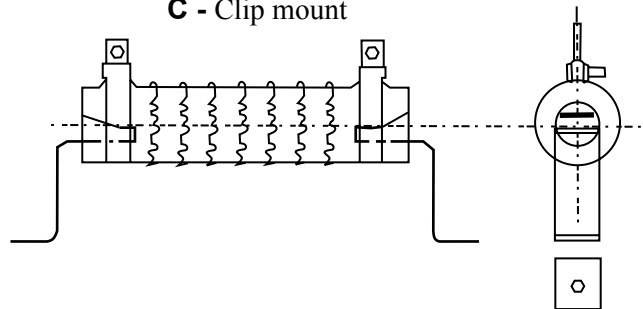

► How to Order

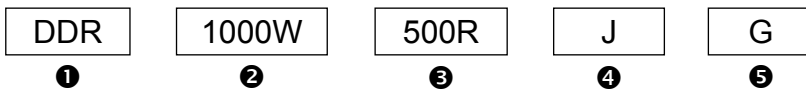

- ❶ Product Type : DDR Type ; DCR Type
- ❷ Rated Power : 10W~1300W ; 100W~250W
- ❸ Resistance Value (Ω) : (Ω) indicates resistance value in units of ohms.
- ❹ Resistance Tolerance :

Code	Resistance Tolerance
J	($\pm 5\%$)
K	($\pm 10\%$)

❺ Assembly Method

Code	Assembly Method
N	No mount
C	Clip mount.
G	Horizontal mount.
Z	Vertical mount