

INCREMENTAL ENCODERS, PIF11 RANGE, *ROBUSTECH™*

- Especially designed for heavy duty: steel and paper mills, lumber, cranes, etc.
- Excellent resistance to shocks/vibrations and to extreme axial/radial loads
- Connection with terminal box with LED option, cable or connectors output
- Digital incremental output, optional analog output (tachocoders, optotacho)
- Mechanical over-speed switch: optional
- Max control option : detection of shocks, vibrations, temperatures...
- Solid shaft of 12 mm or 11 mm with RE0 115 mm flange (Euroflange B10) for tachogenerator type mounting



PIF_11 connection G3R (radial cable gland)

PIF_11 connection BR (terminal box)

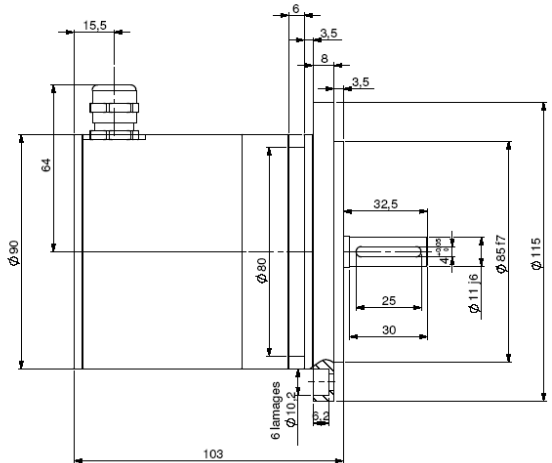
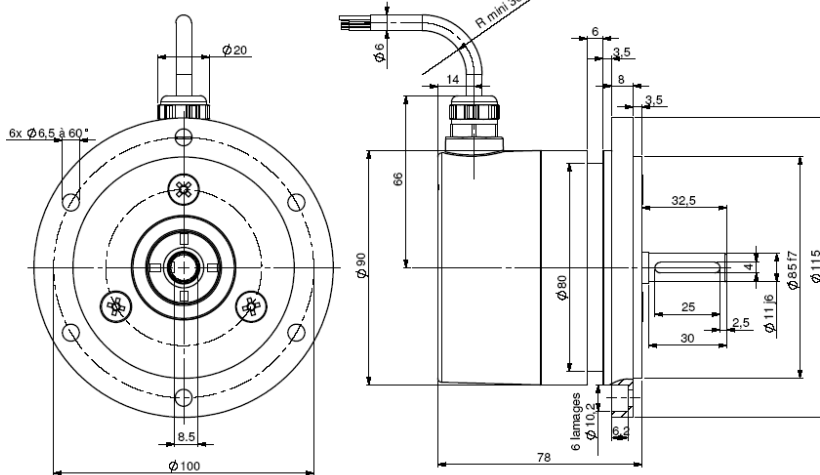

PIF_12 connection G6R (radial M23)

PIF_12 connection BR (terminal box)

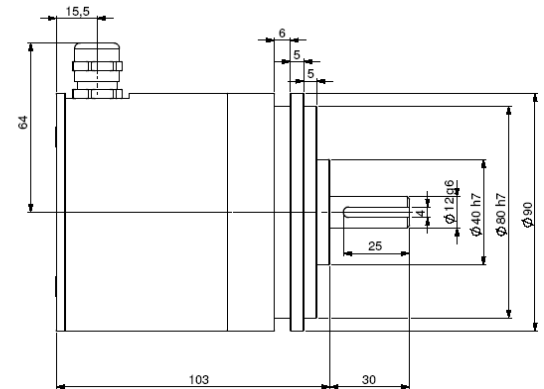
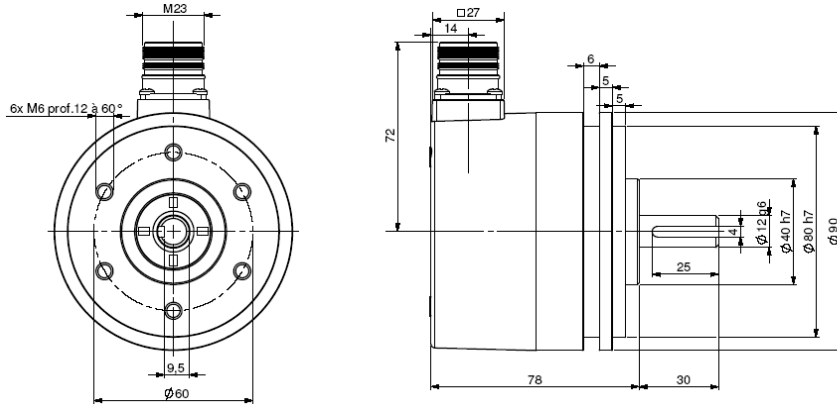

Material (connector or cable output version) Stainless steel option	Cover : zinc alloy	Vibration (EN60068-2-6)	≤ 200 m.s ⁻² (10 ... 1 000 Hz)
	Body: aluminium		EMC
Material (terminal box version) Stainless steel option	Cover: aluminium	Isolation	1 000 Veff
	Body: aluminium	Weight (connector or cable version)	1,1kg zinc alloy cover, alu body
Shaft	Stainless steel		2,4kg zinc alloy cover, stainless steel body
Bearings	6001 serie	Weight (terminal box version)	2,6kg stainless steel cover and body
Maximal loads	Axial : 100 N		1,3kg alu cover, alu body
	Radial : 200 N	Operating temperature	2,6kg alu cover, stainless steel body
Shaft inertia moment	≤ 15.10 ⁻⁶ kg.m ²		2,8kg stainless steel cover and body
Torque	≤ 10.10 ⁻³ N.m	Storage temperature	- 20 ... + 80 °C (Encoder T°)
Permissible max. speed	9 000 min ⁻¹	Protection(EN 60529)	IP 67 (cable), IP 66 (connector)
Continuous max. speed	6 000 min ⁻¹	Theoretical mechanical lifetime 10 ⁹ turns (F _{axial} / F _{radial})	
Shaft seal	Viton double lips	20 N / 30 N : 360	50 N / 100 N : 30
Shock (EN60068-2-27)	≤ 500 m.s ⁻² (during 6ms)		100 N / 200 N : 2,5

OUTPUT ELECTRONIC / SUPPLY

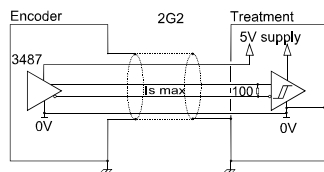

2G2 electronic (100kHz)
 Supply : 5Vdc ± 10%
 Cons. without load : 100mA max
 Current per channel : 40mA max
 0 max (Is=20mA) : $V_{ol} = 0,5Vdc$
 1 min (Is=20mA) : $V_{oh} = 2,5Vdc$

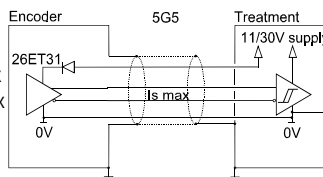

5G5 electronic (100kHz)
 Supply : 11 to 30Vdc
 Cons. without load : 75mA max
 Current per channel : 40mA max
 0 max (Is=20mA) : $V_{ol} = 0,5Vdc$
 1 min (Is=20mA) : $V_{oh} = V_{cc}-3Vdc$

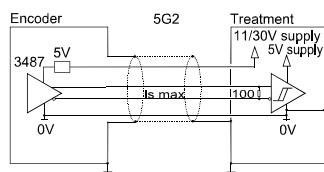

5G2 electronic (100kHz)
 Supply : 11 to 30Vdc
 Cons. without load : 75mA max
 Current per channel : 40mA max
 0 max (Is=20mA) : $V_{ol} = 0,5Vdc$
 1 min (Is=20mA) : $V_{oh} = 2,5Vdc$

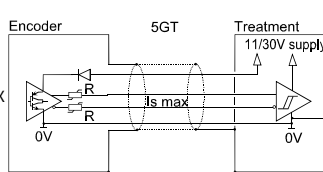

5GT electronic, optional (100kHz)
 Supply : 11 to 30Vdc
 Cons. without load : 75mA max
 Current per channel : 40mA max
 0 max (Is=20mA) : $V_{ol} = 0,5Vdc$
 1 min (Is=20mA) : $V_{oh} = V_{cc}-2,5Vdc$

5GT electronic permits to drive very long (contact our factory)

Available in option :

- 3G3 electronic, supply between 15 and 30Vdc, push-pull output regulated 12Vdc
- 5GH electronic permits to drive different inputs (PLC + display for example)

Protection against short circuits for electronics: 5G5, 5GT, 3G3

Protection against polarity inversion for all electronics: 2G2

“Option “Max control” : the encoder gives on real time its physical environment parameters: shocks and vibrations, too high or too low temperature, too low or too high supply, quality of the output signals : upon request..”



STANDARD CONNECTION

		-	+	A	B	0	A/	B/	0/	Ground
BR	Terminal box	1	2	3	4	5	6	7	8	On cable gland
G6	12 pins CW	1	2	3	4	5	6	7	8	Connector body
G8	12 pins CCW	10 + 11	2 + 12	8	5	3	1	6	4	Connector body
C	PVC cable 8 wires 8230/020	WH white	BN brown	GN green	YE yellow	GY grey	PK pink	BU blue	RD red	General shielding
G	PUR cable 12 wires 8230/050	WH white + WH/GN white/green	BU blue + BN/GN brown/green	GY grey	BN brown	RD red	PK pink	GN green	BK black	General shielding

ORDERING CODE (Special versions upon request, for ex. over-speed switches, special flanges/electronics/connections...)

	Shaft Ø	Available electronic		Output signal	Resolution	Connection	Connection orientation
PIF11	11 : 11mm	2G2, 5G2, 5G5, 5GT, 5GH, 3G3		MC A,A/B,B/,0/0 (0, A&B gated) A : A,A/B,B/,0/0 (0, A gated) N : A,A/B,B/,0/0 (0 ungated) K : max control option	10 000 max	G6 : M23 12pins CW G5 : M23 12pins CW G8 : M23 12 broches CCW B : terminal box G1 : solenoid 4pins	R : radial A : axial
PBF11 Stainless steel body	12 : 12mm	Supply	Output stage				
PXF11 Stainless steel cover and body	C1 : 11mm Length 20mm C2 : 12mm Length 25mm	2 : 5Vdc 5 : 11 to 30Vdc 3 : 15 to 30Vdc	G2 : driver 5Vdc RS422 G3 : driver 12Vdc G5 : push-pull GT : push-pull 11-30Vdc transistorized GH : push-pull 11-30Vdc 150 mA				
Ex: PIF11	11 //	5	G5	MC //	5 000 //	B	R

Available resolutions : 1 2 3 4 5 6 7 8 9 10 12 13 14 15 16 19 20 21 24 25 26 28 29 30 32 35 36 39 40 43 45 46 48 50 54 56 58 60 62 63 64 66 67 70 72 74 75 76 80 84 86 88 89 90 91 94 96 100 107 110 120 122 123 125 127 128 130 132 135 138 140 147 150 157 159 160 168 169 170 172 175 180 188 191 196 200 201 205 220 222 225 234 240 241 242 245 246 248 250 254 255 256 258 259 267 268 275 283 285 295 300 305 314 315 318 320 330 340 350 360 367 375 378 380 381 388 390 397 400 405 410 424 425 438 443 450 471 480 489 495 500 505 512 515 534 540 550 565 580 600 623 625 628 630 632 635 650 660 700 720 746 750 752 754 800 810 840 860 880 891 900 942 990 1000 1024 1080 1100 1131 1200 1225 1250 1260 1280 1290 1400 1414 1440 1500 1536 1570 1600 1620 1630 1750 1800 1885 2000 2048 2250 2400 2500 2640 3000 3456 3600 3680 3750 4000 4096 4500 4900 5000 7200 9000 10000