

TECHNICAL 1 DATA

RELATIVE HUMIDITY SENSOR

HS1100LF / HS1101LF

Meets RoHS regulations

Based on a unique capacitive cell, these relative humidity sensors are designed for high volume, cost sensitive applications such as **office automation, automotive cabin air control, home appliances, and industrial process control systems**. They are also useful in all applications where humidity compensation is needed.

MAIN FEATURES

- ✧ Lead free components
- ✧ Full interchangeability with no calibration required in standard conditions
- ✧ Instantaneous desaturation after long periods in saturation phase
- ✧ Compatible with automatized assembly processes, **including Pb free wave soldering and reflow processes** (1)
- ✧ High reliability and long term stability
- ✧ Patented solid polymer structure
- ✧ Suitable for linear voltage or frequency output circuitry
- ✧ Fast response time and very low temperature coefficient
- ✧ Part may be washed with distilled water.
- ✧ Individual marking for compliance to stringent traceability requirements
 - (1) soldering temperature profiles available on request / contact us at application@humirel.com



MAXIMUM RATINGS

Ratings	Symbol	Value	Unit
Operating Temperature	Ta	-60 to 140	°C
Storage Temperature	Tstg	-60 to 140	°C
Supply Voltage (Peak)	Vs	10	Vac
Humidity Operating Range	RH	0 to 100	% RH

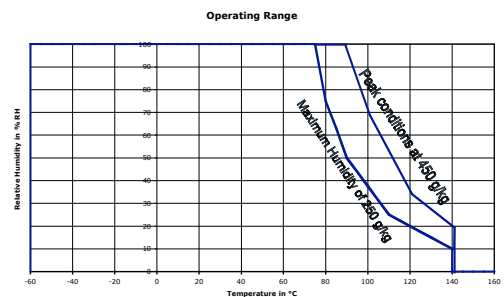

CHARACTERISTICS

Humidity sensor (Ta = 25°C, measurement frequency @ 10kHz / 1V unless otherwise noted)

Characteristics	Symbol	Min.	Typ.	Max.	Unit.
Humidity measuring range	RH	1		99	%RH
Supply voltage	Vs			10	V
Nominal capacitance @ 55% RH*	C	177	180	183	pF
Temperature coefficient	Tcc			0.01	pF/°C
Averaged Sensitivity from 33% to 75% RH	$\Delta C / \% RH$		0.31		pF/% RH
Leakage current (Vcc = 5 Volts)	I			1	nA
Recovery time after 150 hours of condensation	tr		10		s
Humidity Hysteresis				+/-1	%RH
Long term stability	-		+/-0.5		%RH/yr
Time constant (33 to 80 % RH, still air @ 63%)	ta		3	5	s
Deviation to typical response curve (10% to 90%) RH			+/-2		%RH

*tighter specification available on request

深圳市新世联科技有限公司
光之神电子有限公司(香港)

TYPICAL RESPONSE: look-up table (Polynomial Reference curve)

Polynomial response of HS1100LF/HS1101LF:

$$C \text{ (pF)} = C@55 \% * (3.903 \cdot 10^{-8} * RH^3 - 8.294 \cdot 10^{-6} * RH^2 + 2.188 \cdot 10^{-3} * RH + 0.898)$$

Typical response look-up table (Polynomial Reference curve) "10KHz/1V"

RH (%)	0	5	10	15	20	25	30	35	40	45	50
Cp (pF)	161.6	163.6	165.4	167.2	169.0	170.7	172.3	173.9	175.5	177.0	178.5
RH (%)	55	60	65	70	75	80	85	90	95	100	
Cp (pF)	180	181.4	182.9	184.3	185.7	187.2	188.6	190.1	191.6	193.1	

Reversed Polynomial response of HS1100LF/HS1101LF:

$$RH (\%) = -3.4656 \cdot 10^{-3} * X^3 + 1.0732 \cdot 10^{-4} * X^2 - 1.0457 \cdot 10^{-4} * X + 3.2459 \cdot 10^{-3}$$

With $X = C(\text{read}) / C@55\% RH$

MEASUREMENT FREQUENCY INFLUENCE

In this data sheet, all capacitance measurements are done @ 10 kHz /1Volt. However, the sensor can operate without restriction from 5 kHz to 300 kHz.

POLARIZATION

In order to get a better reproducibility during measurements, always connect the case of the header (pin 2) to the ground of the circuit. The case of the header is located on the opposite side of the tab.

SOLDERING INSTRUCTIONS

We recommend to take specific attention to soldering conditions to get the best performance of Humirel sensors. See Application Note. To get it, please contact: application@humirel.com.

PROPORTIONAL VOLTAGE OUTPUT CIRCUIT

Block diagram

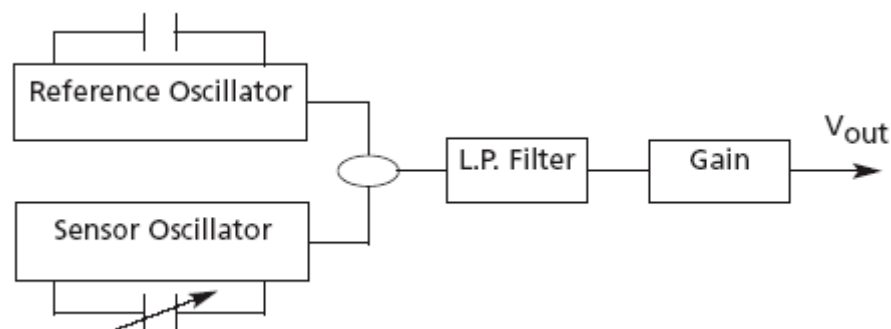

深圳市新世联科技有限公司
光之神电子有限公司(香港)

FREQUENCY OUTPUT CIRCUITS

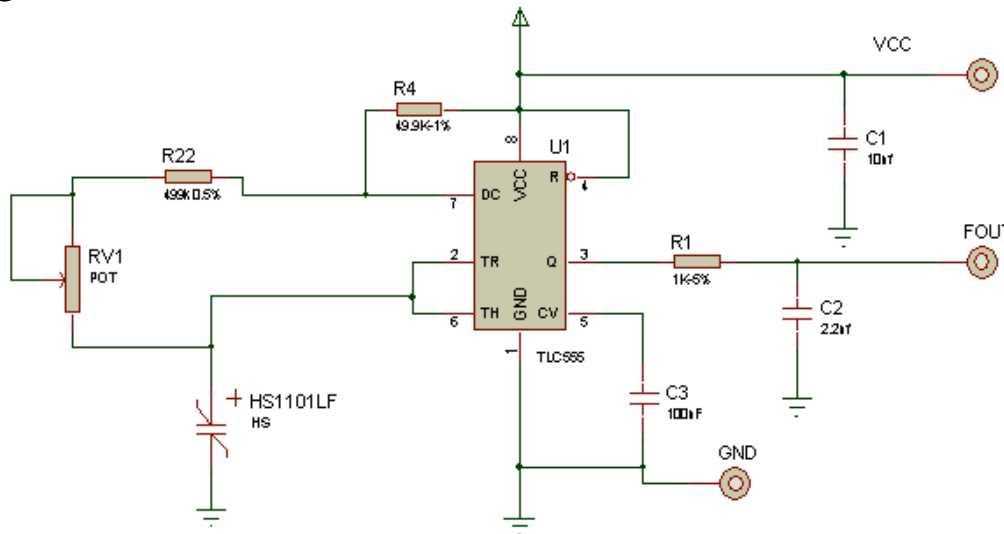

Note: R22=499k / R4=49.9k / R1=1 k / RV1=50 k potentiometer / C1=10nF / C2=2.2nF / C3=100nF

This circuit is the typical astable design for 555. The HS1100LF/HS1101LF, used as variable capacitor, is connected to the TRIG and THRES pin. Pin 7 is used as a short circuit pin for resistor R4. The HS1100LF/HS1101LF equivalent capacitor is charged through R22 and R4 to the threshold voltage (approximately 0.67Vcc) and discharged through R22 only to the trigger level (approximately 0.33Vcc) since R4 is shorted to ground by pin 7.

Since the charge and discharge of the sensor run through different resistors, R22 and R4, the duty cycle is determined by:

- $t_{high} = C @ \%RH * (R22 + R4) * \ln 2$
- $t_{low} = C @ \%RH * R22 * \ln 2$
- $F = 1 / (t_{high} + t_{low}) = 1 / (C @ \%RH * (R4 + 2 * R22) * \ln 2)$
- **Output duty cycle = $t_{high} * F = R22 / (R4 + 2 * R22)$**

To provide an output duty cycle close to 50%, R4 should be very low compared to R22 but never under a minimum value. Resistor R3 is a short circuit protection. 555 must be a CMOS version.

Typical response look-up table

RH (%)	0	5	10	15	20	25	30	35	40	45	50
Fout (Hz)			7155	7080	7010	6945	6880	6820	6760	6705	6650
RH (%)	55	60	65	70	75	80	85	90	95	100	
Fout (Hz)	6600	6550	6500	6450	6400	6355	6305	6260	6210		

Measurement Error vs Stray Capacitance

- Special attention is required in order to minimize stray capacitance in the layout. The added capacitance will act as a parallel capacitance with the sensor and create a measurement error.
- A careful coating of PCB and components must be implemented to prevent unexpected deviations of Fout in high humidity conditions.

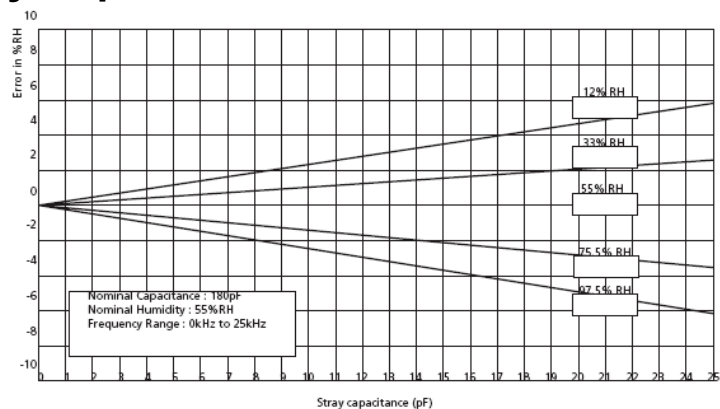

深圳市新世联科技有限公司
光之神电子有限公司(香港)

TECHNICAL 4 DATA

QUALIFICATION PROCESS

HS1100LF/HS1101LF sensors have been qualified through a complete qualification process taking in account many of the requirements of the JEDEC standard including:

- Solder heat and solderability including lead free process.
- Pb free wave soldering and reflow soldering process(260°C) + DI water clean at 45°C
- Mechanical shock JESD-22-B104-A
- Vibration - Variable frequency(20 to 2000Hz) JESD-22-B103-A
- Marking permanency
- ESD - Electrostatic Discharge -Air Gun +- 15kV(IEC 1000)
- Salt Atmosphere JESD22-A107-A
- Temperature Cycling - 40°C / +125°C
- High Temperature / Humidity Operating Life - 93%RH / 60°C for 1000 hours
- Low Humidity storage life - RH < 10%/23°C - 1000 hours
- Resistance to immersion in water at ambient temperature and 80°C
- High temperature storage 140°C for 168 hours.
- Resistance to many chemicals linked to home appliances/automotive or consumer applications.

ENVIRONMENTAL AND RECYCLING

HS1100LF/HS1101LF sensors are lead free components and are compatible with Pb Free soldering processes.HS1101LF/HS1100LF sensors are free from Cr (6+), Cd and Hg.

PACKAGE OUTLINE

Dimensions in millimeters

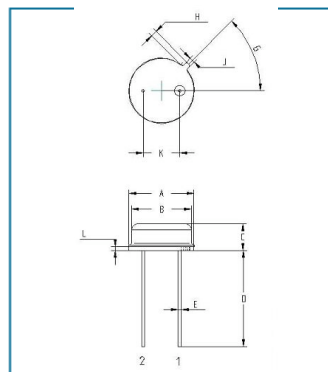

Dimension	Min (mm)	Max (mm)
A	9.00	9.30
B	8.00	8.50
C	3.50	3.90
D	12.00	14.00
E	0.40	0.50
G	45° BCS	
H	0.70	1.10
J	0.70	0.90
K	4.83	5.33
L	0.4 BCS	

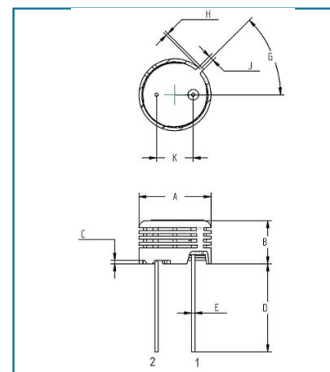

Dimension	Min (mm)	Max (mm)
A	9.70	10.20
B	5.70	6.20
C	0.40	0.60
D	12.00	14.00
E	0.40	0.50
G	45° BCS	
H	0.70	1.10
J	0.70	0.90
K	4.83	5.33

To distinguish HS1101LF from HS1101, HS1101LF is designed with a black plastic cap

ORDERING INFORMATION:

CAPACITIVE RELATIVE HUMIDITY SENSOR.

HS1101LF: HPP801A031 (MULTIPLE PACKAGE QUANTITY OF 48 PIECES)

HS1100LF: HPP800A031 (MULTIPLE PACKAGE QUANTITY OF 50 PIECES)

深圳市新世联科技有限公司
光之神电子有限公司(香港)