

**UNCONTROLLED DOCUMENT
WILL NOT BE UPDATED**

REVISIONS				
REV. SYM.	E.C.O. NUMBER	DESCRIPTION	BY DATE	APP'D DATE
9		ADDED SET INFO	ENF 1-18-10	RRR 1-18-10

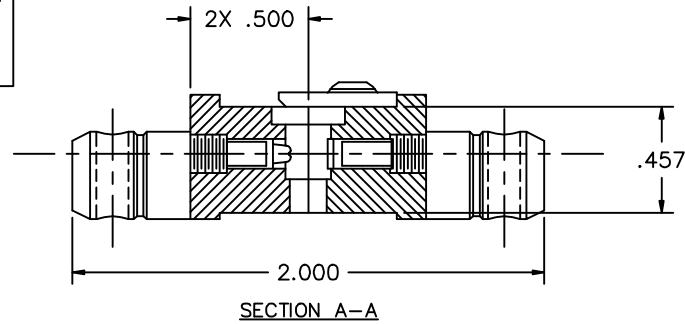

TO SET DIE:

1. UNLOCK & BACK INDENTERS SLIGHTLY OUT OF THE CAVITY
2. INSERT Y631-SG INTO HOLE FROM BACK SIDE OF DIE AS FAR AS IT WILL GO WITH THE SLOT ALIGNED WITH THE FLAT RECTANGULAR INDENTER
3. ADJUST THE FLAT RECTANGULAR INDENTER UNTIL IT TOUCHES THE SET GAGE (PAY CLOSE ATTENTION TO LINE IT UP IN THE SLOT & DO NOT OVER TIGHTEN)
4. ADJUST POINTED INDENTER UNTIL IT TOUCHES THE SET GAGE (DO NOT OVER TIGHTEN)
5. REMOVE Y631-SG
6. VERIFY INDENTER GAGE WITH G524 AND ADJUST POINTED INDENTER IF NEEDED

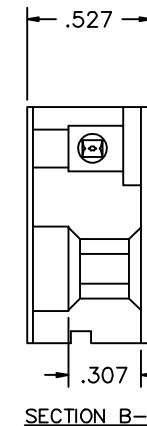
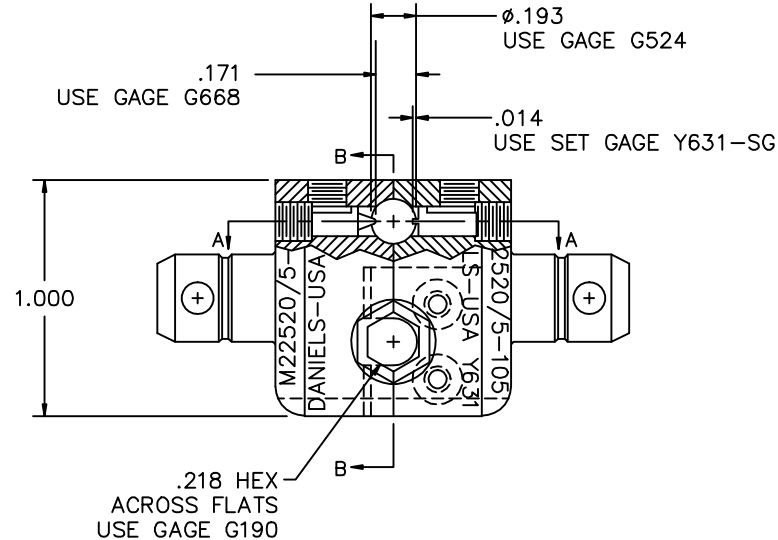

1. TROMPETER CD5-4.

NOTES:

RESTRICTED & CONFIDENTIAL		MATERIAL	ITEM	PART NO.	QTY.	DESCRIPTION/REMARKS			
CONFIDENTIAL PROPERTY OF DANIELS MANUFACTURING CORP. NOT TO BE DISCLOSED TO OTHERS, REPRODUCED OR USED FOR ANY OTHER PURPOSE, EXCEPT AS AUTHORIZED IN WRITING BY DANIELS MANUFACTURING. MUST BE RETURNED TO DANIELS MANUFACTURING CORP. ON COMPLETION OF ORDER OR OTHER PURPOSE FOR WHICH LEVY.		HEAT TREAT	DRN.	B. KILPATRICK	DATE	4-17-98			
			CHK'D.	DAD	DATE	4-98			
			APP'D.		DATE				
			APP'D.		DATE				
DO NOT SCALE DRAWING		FINISH	NOTE:		WHERE USED:				
			THIS DRAWING IS AN OUTLINE DRAWING OF THE RESPECTIVE DMC PART NUMBER INDICATED. ACTUAL DMC PART NUMBER IS DRAWING NUMBER WITHOUT THE "-ENV" SUFFIX.		SIZE	SCALE	CAD P/N	SHEET	OF
					B	2X	Y631-ENV	1	1
					POSTING	DWG. NO. Y631-ENV		REV.	9

DMC DANIELS MANUFACTURING CORP.
ORLANDO, FLORIDA
GAGE 11851

DIE SET
ENVELOPE DRAWING