

---

# MPC837xE-RDS

## Reference Design Platform User's Guide

Document Number: MPC837xERDSUG  
Rev. 1.0  
12/2008



## **How to Reach Us:**

### **Home Page:**

[www.freescale.com](http://www.freescale.com)

### **Web Support:**

<http://www.freescale.com/support>

### **USA/Europe or Locations Not Listed:**

Freescale Semiconductor, Inc.  
Technical Information Center, EL516  
2100 East Elliot Road  
Tempe, Arizona 85284  
1-800-521-6274 or +1-480-768-2130  
[www.freescale.com/support](http://www.freescale.com/support)

### **Europe, Middle East, and Africa:**

Freescale Halbleiter Deutschland GmbH  
Technical Information Center  
Schatzbogen 7  
81829 Muenchen, Germany  
+44 1296 380 456 (English)  
+46 8 52200080 (English)  
+49 89 92103 559 (German)  
+33 1 69 35 48 48 (French)  
[www.freescale.com/support](http://www.freescale.com/support)

### **Japan:**

Freescale Semiconductor Japan Ltd.  
Headquarters  
ARCO Tower 15F  
1-8-1, Shimo-Meguro, Meguro-ku,  
Tokyo 153-0064  
Japan  
0120 191014 or +81 3 5437 9125  
[support.japan@freescale.com](mailto:support.japan@freescale.com)

### **Asia/Pacific:**

Freescale Semiconductor China Ltd.  
Exchange Building 23F  
No. 118 Jianguo Road  
Chaoyang District  
Beijing 100022  
China  
+86 10 5879 8000  
[support.asia@freescale.com](mailto:support.asia@freescale.com)

### **For Literature Requests Only:**

Freescale Semiconductor Literature Distribution  
Center  
P.O. Box 5405  
Denver, Colorado 80217  
1-800-441-2447 or +1-303-675-2140  
Fax: +1-303-675-2150  
[LDCForFreescaleSemiconductor@hibbert-](mailto:LDCForFreescaleSemiconductor@hibbert-)

Document Number: MPC837xERDSUG

Rev. 1.0

12/2008

Information in this document is provided solely to enable system and software implementers to use Freescale Semiconductor products. There are no express or implied copyright licenses granted hereunder to design or fabricate any integrated circuits or integrated circuits based on the information in this document.

Freescale Semiconductor reserves the right to make changes without further notice to any products herein. Freescale Semiconductor makes no warranty, representation or guarantee regarding the suitability of its products for any particular purpose, nor does Freescale Semiconductor assume any liability arising out of the application or use of any product or circuit, and specifically disclaims any and all liability, including without limitation consequential or incidental damages. "Typical" parameters that may be provided in Freescale Semiconductor data sheets and/or specifications can and do vary in different applications and actual performance may vary over time. All operating parameters, including "Typicals", must be validated for each customer application by customer's technical experts. Freescale Semiconductor does not convey any license under its patent rights nor the rights of others. Freescale Semiconductor products are not designed, intended, or authorized for use as components in systems intended for surgical implant into the body, or other applications intended to support or sustain life, or for any other application in which the failure of the Freescale Semiconductor product could create a situation where personal injury or death may occur. Should Buyer purchase or use Freescale Semiconductor products for any such unintended or unauthorized application, Buyer shall indemnify and hold Freescale Semiconductor and its officers, employees, subsidiaries, affiliates, and distributors harmless against all claims, costs, damages, and expenses, and reasonable attorney fees arising out of, directly or indirectly, any claim of personal injury or death associated with such unintended or unauthorized use, even if such claim alleges that Freescale Semiconductor was negligent regarding the design or manufacture of the part.

Freescale™ and the Freescale logo are trademarks of Freescale Semiconductor, Inc. All other product or service names are the property of their respective owners.

© Freescale Semiconductor, Inc. 2008. All rights reserved.



# Contents

## About This Book

Audience .....	5
Organization .....	5
Definitions, Acronyms, and Abbreviations .....	5
References .....	6

## Chapters

1	Introduction .....	7
1.1	Overview .....	7
1.2	Features .....	7
2	MPC837xE-RDS Board .....	9
2.1	Board-Level Functions .....	10
2.1.1	Reset and Reset Configurations .....	10
2.1.2	External Interrupts .....	11
2.1.3	Clock Distribution .....	12
2.1.4	DDR2 SDRAM Controller .....	13
2.1.5	Local Bus Controller .....	14
2.1.6	Flash Memory .....	15
2.1.7	I <sup>2</sup> C .....	15
2.1.8	SATA Controller .....	16
2.1.9	PCI Express Interface (PCI-E & Mini PCI-E) .....	16
2.1.10	10/100/1000 BaseT Interface .....	16
2.1.11	RS-232 Port .....	17
2.1.12	USB 2.0 Interface .....	17
2.1.13	PCI Subsystem .....	18
2.1.14	COP/JTAG Port .....	18
2.2	MPC837xE-RDS Assembly .....	20
2.3	Connectors .....	22
2.3.1	COP Connector .....	22
2.3.2	RS-232C Connectors .....	23
2.3.3	Serial ATA (SATA) Connector .....	23
2.3.4	Mini PCI Connector .....	23
2.3.5	Power Connector .....	24
2.4	LEDs .....	24
2.4.1	Power-on LED .....	24
2.4.2	RDS Programmable LEDs .....	24
2.4.3	Ethernet LEDs .....	25
2.5	MPC837xE-RDS Board Configuration .....	25
2.5.1	EEPROM .....	25
2.5.2	PCI Operating Frequency .....	25

2.5.3	Reset Configuration Word .....	26
2.5.4	Power Supply .....	30
2.5.5	Chip-Select Assignments and Memory Map .....	30
2.6	Specifications .....	30
2.7	Mechanical Data .....	32
3	Board Bootup .....	32
3.1	Board Jumper Settings .....	33
3.2	External Connections .....	34
4	MPC837xE-RDS Software .....	34
4.1	Application Features for MPC837xE-RDS reference software .....	34
4.2	Application Connections .....	36
5	Unit Assembly .....	37
5.1	Assembling the Enclosure and Board Assembly .....	37
5.2	Attaching a Wi-Fi Card to the Product .....	37
5.3	Attaching a SATA hard disk to the Product .....	37

## About This Book

This document presents system architecture, board-level functions, external connections, and software features for the MPC837xE-RDS board. It provides guidance of how to operate this product, making it easy for the user to connect with the outside world. The front part of this book focuses primarily on the board and functions. The latter part of the book focuses on the mechanical aspects.

## Audience

Users who want to become familiar with the MPC837xE-RDS board, its characteristics, and how to program the device.

## Organization

[Chapter 1, Introduction](#), describes the features and block diagram for the MPC837xE-RDS board.

[Chapter 2, MPC837xE-RDS Board](#), describes the board in terms of its hardware: board-level functions, connectors, configurations, and board mechanical data.

[Chapter 3, Board Bootup](#), describes the board settings and physical connections needed to boot the MPC837xE-RDS board.

[Chapter 4, MPC837xE-RDS Software](#), describes the main software features for MPC837xE-RDS board.

## Definitions, Acronyms, and Abbreviations

The following list defines the acronyms and abbreviations used in this document.

NAS	Network-Attached Storage
RAID	Redundant Array of Inexpensive Disks
CPU	Central Processing Unit
PoE	Power over Ethernet
DDR2 SDRAM	Double-Data-Rate Two Synchronous Dynamic Random Access Memory
NOR Flash	Nor Gate Flash
eTSEC	Enhanced Three-Speed Ethernet Controller
RGMI	Reduced Gigabit Media Independent Interface
WAN	Wide Area Network
LAN	Local Area Network
USB	Universal Serial Bus
ULPI	USB Low-Pin Count Interface
SATA	Serial Advanced Technology Attachment (computer bus)
PCI	Peripheral Component Interconnect (computer bus)
PCI-E	Peripheral Component Interconnect Express (computer bus)
SDHC	Secure Digital High Capacity (SD 2.0 memory card)

I <sup>2</sup> C	Inter-Integrated Circuit (computer bus)
EEPROM	Electrically Erasable Programmable Read-Only Memory
JTAG	Joint Test Action Group
DHCP	Dynamic Host Configuration Protocol
DNS	Domain Name System
VLAN	Virtual Local Area Networks
NAT	Network Address Translation
PAT	Port Address Translation
RIP	Routing Information Protocol
VRRP	Virtual Router Redundancy Protocol
PPPoE	Point-to-Point Protocol over Ethernet
IGMP	Internet Group Management Protocol
UPnP	Universal Plug and Play (computer protocol)
SNMP	Simple Network Management Protocol
QoS	Quality of Service
IPsec	Internet Protocol Security
PPTP	Point-to-Point Tunneling Protocol
L2TP	Layer 2 Tunneling Protocol

## References

The following sources were referenced to produce this book:

- *MPC8379E PowerQUICC™ II Pro Integrated Host Processor Family Reference Manual (MPC8379ERM)*
- *MPC8379E PowerQUICC II Pro Integrated Host Processor Hardware Specifications (MPC8379EEC)*
- *Hardware and Layout Design Considerations for DDR Memory Interfaces (AN2582)*

# 1 Introduction

This section presents the features and block diagram for the MPC837xE-RDS board.

## 1.1 Overview

The MPC837xE-RDS is a reference design based on the MPC8377E PowerQUICC™II Pro processor. It supports applications of Wi-Fi Router, DMS (Digital Media Server), NAS with RAID, or Office in BOX, etc. The documentation for manufacturing the MPC837xE-RDS—including schematic, Gerber files, reference software, Bill Of Material (BOM)—is on the product CD. With the documentation, original equipment manufacturers (OEMs) and original design manufacturers (ODMs) can accelerate the development process and speed time-to-market for their real product.

## 1.2 Features

This section presents the features, specification, and block diagram of the MPC837xE-RDS board. The features are as follows:

- CPU
  - Freescale MPC8377E @ 667 MHz
- Power
  - PoE power solution based on LM5072 up to 30 W output, designed as one daughter module board
  - 48 V DC input used as the alternative power source when PoE is not available
- Memory subsystem
  - On-board 512-MByte DDR2 unbuffered SDRAM
  - 64-MByte NOR Flash
- Interfaces
  - 10/100/1000 BaseT Ethernet ports
    - eTSEC1
      - RGMII interface: WAN, 1 x 10/100/1000 BaseT with RJ-45 interface, using Realtek™ RTL8211B single port 10/100/1000 BaseT PHY. This port supports PoE feature
    - eTSEC 2
      - RGMII interface: LAN, 1 x 10/100/1000 BaseT with RJ-45 interface, using Realtek™ RTL8211B single port 10/100/1000 BaseT PHY
  - USB 2.0 Host
    - ULPI interface: 1 x USB 2.0 Type A Receptacle interface, using SMSC™ USB3300 Hi-Speed USB PHY
  - Serial ATA Controller

## Introduction

- Two standard External SATA connectors
- PCI: 32-bit PCI interface up to 66 Mhz
  - 2x 32-bit 3.3 V mini PCI slots
- PCI Express
  - Two mini PCI Express Connectors, or
  - One mini PCI Express connector and one PCI Express x1 connector
- SDHC
  - One SDHC Card Connector
- I<sup>2</sup>C
  - I<sup>2</sup>C connected to ST M24256 Serial EEPROM
- Board Connectors
  - One DC power jack
  - One internal 2 x 5 RS-232 connector
  - JTAG / COP for debugging
- Form factor
  - Mini ITX form factor (170 mm x 170 mm, or 6693 mils x 6693 mils)
- 6-layer PCB (4 layers signals and separate power and ground layers)
- Certification
  - CE/FCC
- Lead-Free (RoHS)



Figure 1 shows the MPC837xE-RDS board block diagram.

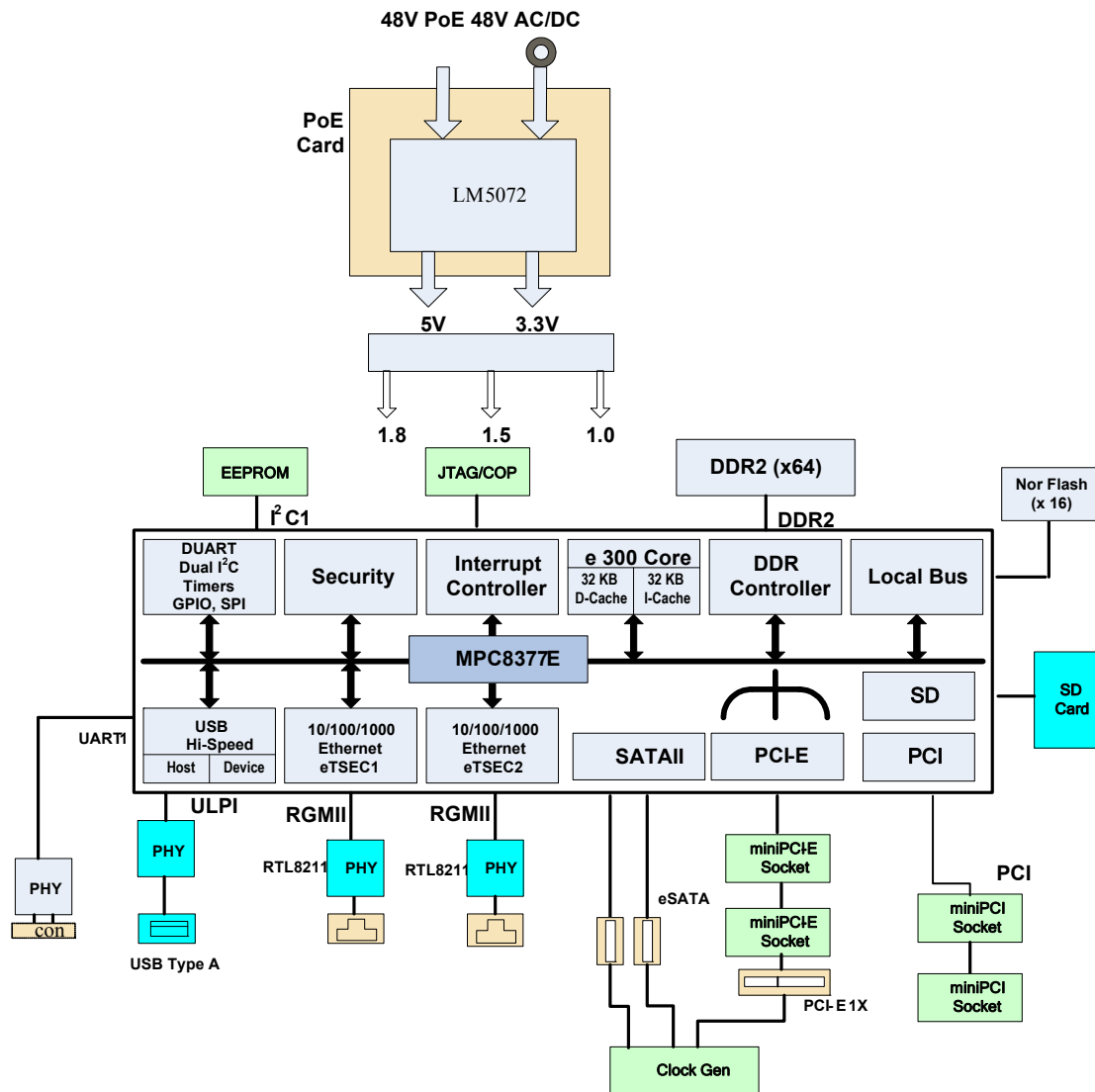

Figure 1. MPC837xE-RDS Board Block Diagram

## 2 MPC837xE-RDS Board

This section presents the board-level functions, specifications, and mechanical data for the MPC837xE-RDS board.

## 2.1 Board-Level Functions

The board-level functions discussed in this section are reset, interrupts, clock distribution, and interface specification.

### 2.1.1 Reset and Reset Configurations

The MPC837xE-RDS reset module generates a single reset to reset the MPC837xE and other peripherals on the board. The reset unit provides power-on reset, hard reset, and soft reset signals in compliance with the MPC837xE hardware specification. Figure 2 shows the reset circuitry.

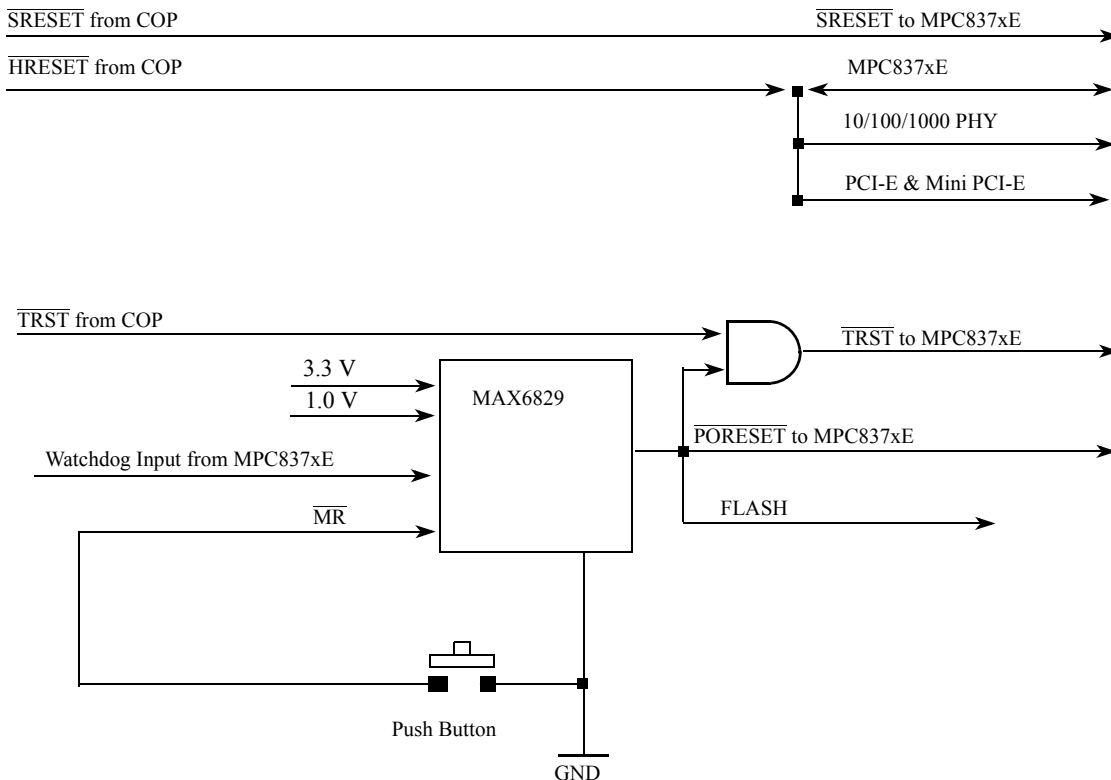

Figure 2. Reset Circuitry of the MPC837xE

- The COP/JTAG port or the MPC837xE generates the signal for hard reset.
- The Maxim MAX6829 device generates the power-on reset. When  $\overline{MR}$  is de-asserted and 3.3 V is ready, the MAX6829 internal timeout guarantees a minimum reset active time of 140 ms before  $\overline{PORESET}$  is de-asserted. This circuitry guarantees a 140 ms  $\overline{PORESET}$  pulse width after 3.3 V reaches the right voltage level, and this meets the specification of the  $\overline{PORESET}$  input of MPC837xE.
- The COP/JTAG port reset provides convenient hard-reset capability for a COP/JTAG controller. The  $\overline{RESET}$  line is available at the COP/JTAG port connector. The COP/JTAG controller can directly generate the hard-reset signal by asserting this line low.
- The pushbutton reset interfaces the  $\overline{MR}$  signal with a debounce capability to produce a manual master reset of the processor.

- The COP/JTAG port also generates the soft reset for the system. Assertion of  $\overline{\text{SRESET}}$  causes the MPC837xE to abort all current internal and external transactions and set most registers to their default values.

## 2.1.2 External Interrupts

Figure 3 shows the external interrupt circuitry to the MPC837xE.

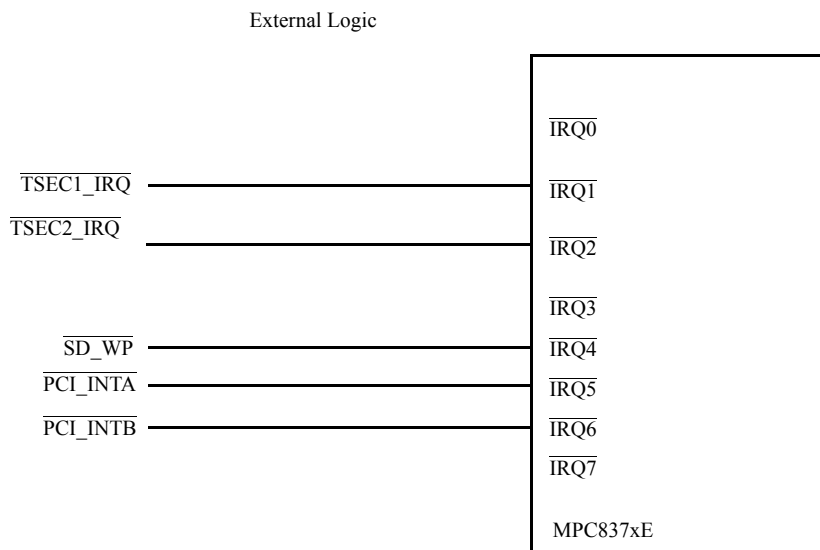

**Figure 3. MPC837xE Interrupt Circuitry**

The following items describe the interrupt signals shown in Figure 3:

- PHY interrupt ( $\overline{\text{TSEC1\_IRQ}}$ ,  $\overline{\text{TSEC2\_IRQ}}$ ). Two RTL8211B GBE PHY interrupts are connected to  $\overline{\text{IRQ1}}$  and  $\overline{\text{IRQ2}}$  of the MPC837xE. The system software can detect the status of the Ethernet link and the PHY internal status.
- SD Card Write Protect interrupt ( $\overline{\text{SD\_WP}}$ ). The SD card socket has a mechanical pin that can indicate whether the SD card inserted is write-protected or not. It is connected to  $\overline{\text{IRQ4}}$  of the MPC837xE.
- PCI interrupt ( $\overline{\text{PCI\_INTA}}$ ,  $\overline{\text{PCI\_INTB}}$ ). Two mini PCI slots  $\overline{\text{INTA}}$  and  $\overline{\text{INTB}}$  drive  $\overline{\text{IRQ5}}$  and  $\overline{\text{IRQ6}}$  of the MPC837xE, respectively

### 2.1.3 Clock Distribution

Figure 4 and Table 1 show the clock distribution on the MPC837xE-RDS board.

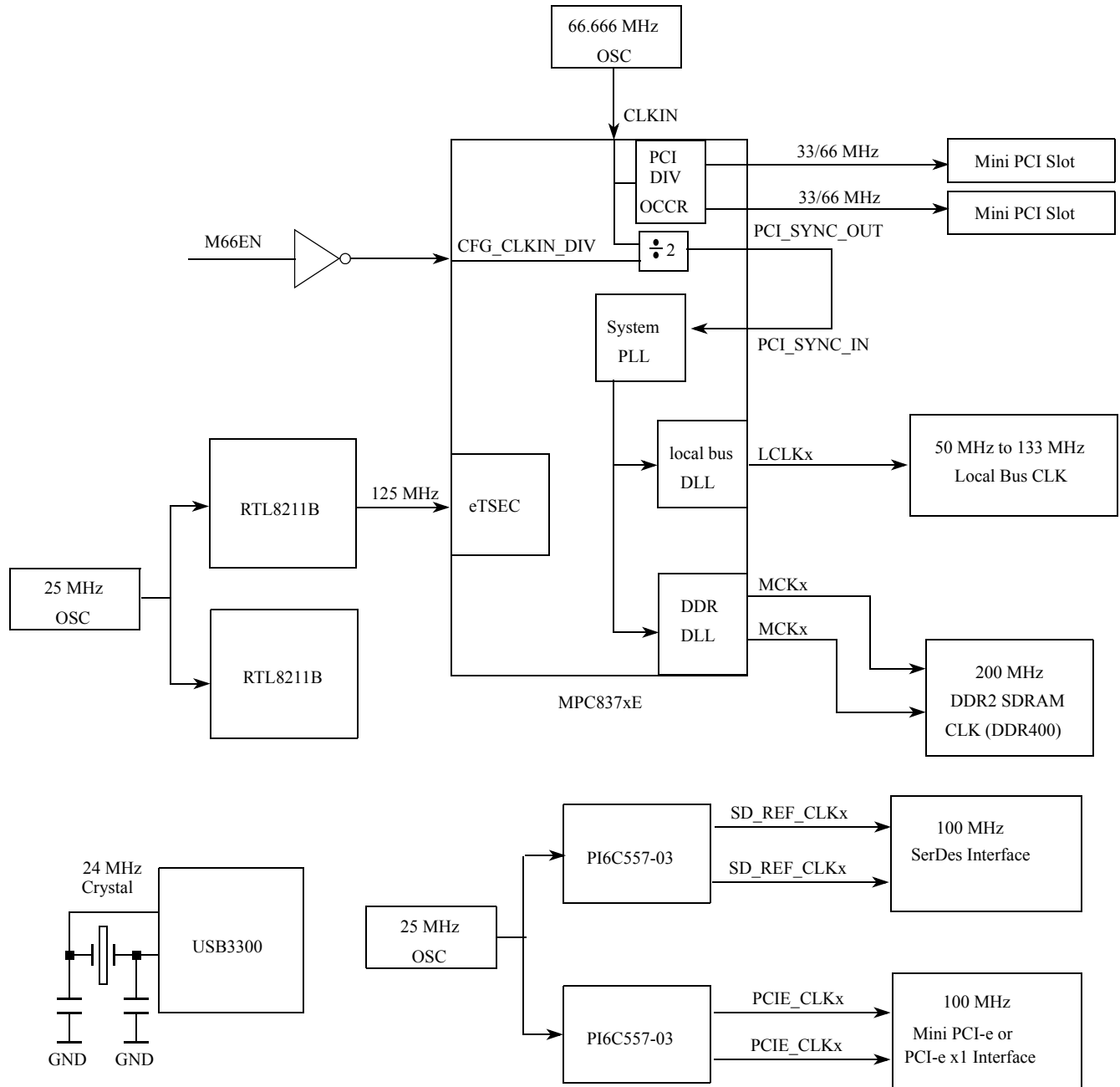

Figure 4. MPC837xE-RDS Clock Distribution Diagram

Table 1. Clock Distribution

Clock Frequency	Module	Generated by	Description
66.666 MHz	MPC837xE CLKIN	66.666 MHz oscillator	The MPC837xE uses CLKIN to generate the PCI_SYNC_OUT clock signal, which is fed back to the internal system PLL through the PCI_SYNC_IN signal. From the power-on reset configuration, the internal PLL generates the CSB clock, which is fed to the e300 core PLL for generating the e300 core clock. The PCI M66EN pin is inverted for CFG_CLKIN_DIV configuration input, which selects whether the PCI_SYNC_OUT signal is CLKIN or CLKIN/2.
125 MHz	MPC837xE eTSEC	RTL8211B	The gigabit Ethernet PHY (RTL8211B) provides a 125-MHz clock for eTSEC operation.)
200 MHz	DDR2 SDRAM	MPC837xE	The DDR memory controller is configured to use the 1:1 mode CSB to DDR clock for the DDR interface. The local bus clock uses CCB/n clock, where n is configured from the LCRR register.
25 MHz	GBE PHY (RTL8211B)	25 MHz oscillator	The 25 MHz oscillator generates the clock for RTL8211B.
33/66 MHz	Mini PCI slot	MPC837xE	The PCI module uses the PCI_SYNC_IN as its clock source. The trace of the PCI_SYNC_IN/PCI_SYNC_OUT signal is synchronized with all the PCI signals of the PCI slots.
24 MHz	USB PHY (USB3300)	24 MHz crystal	
100 MHz	SerDes Interface	25 MHz oscillator and PI6C557-03 clock generator	The SerDes reference clock uses 100 MHz.
100 MHz	Mini PCI-e and PCI-e x1 Interface	25 MHz oscillator and PI6C557-03 clock generator	

### 2.1.4 DDR2 SDRAM Controller

MPC837xE uses DDR2 SDRAM as the system memory. The DDR2 interface uses the SSTL2 driver/receiver and 1.8 V power. A  $V_{ref} 1.8V/2$  is needed for all SSTL2 receivers in the DDR2 interface. For details on DDR timing design and termination, refer to the Freescale application note entitled *Hardware and Layout Design Considerations for DDR Memory Interfaces* (AN2582). [Figure 5](#) shows the DDR SDRAM controller connection.

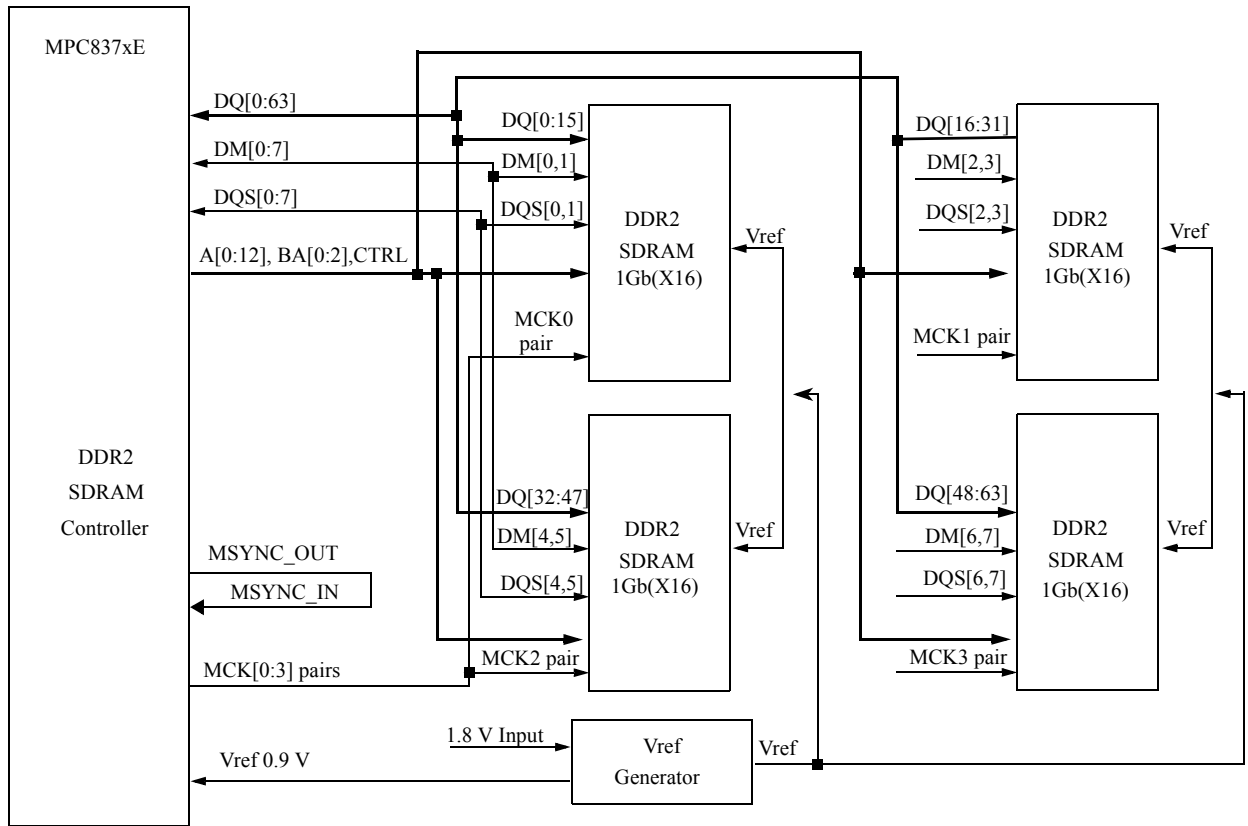

Figure 5. DDR2 SDRAM Connection

### 2.1.5 Local Bus Controller

The MPC837xE local bus controller has a 32-bit LAD[0–31] address that consists of data multiplex bus and control signals. The local bus speed is up to 133 MHz. To interface with the standard memory device, an address latch must provide the address signals. The LALE is used as the latching signal. To reduce the load of the high speed 32-bit local bus interface, there is a data buffer for all low-speed devices attached to the memory controller. The local bus only drives the 64MB NOR Flash memory on the MPC837xE-RDS board:

Figure 6 shows the block diagram and connections for the local bus.

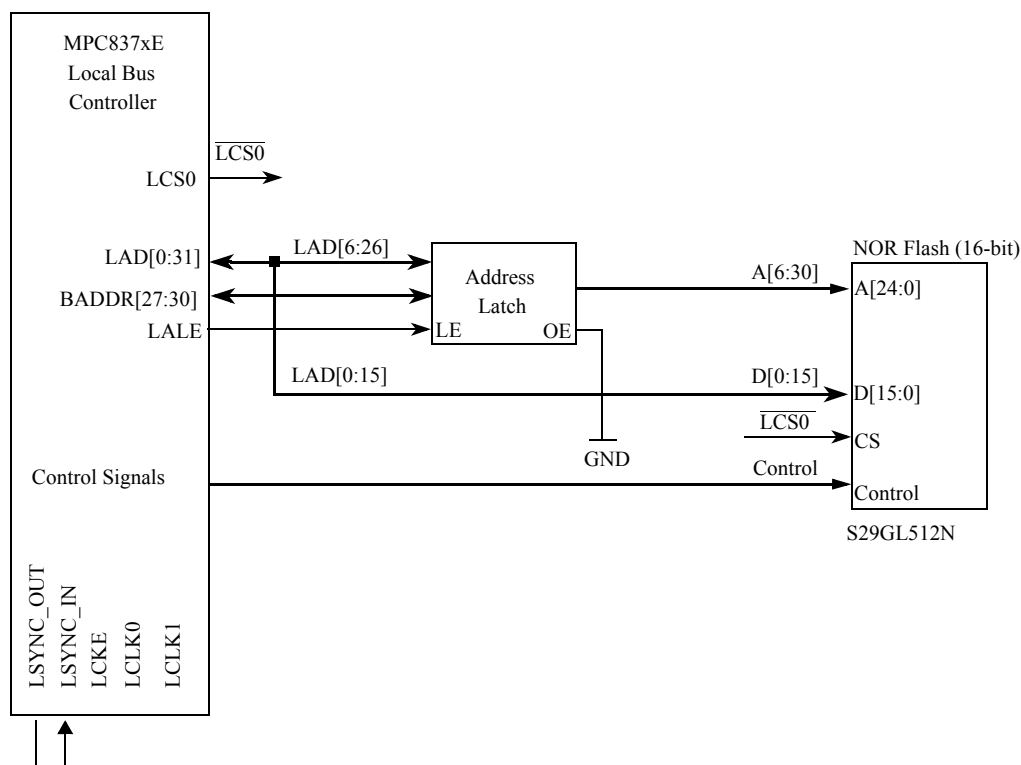

Figure 6. Local Bus Connections

## 2.1.6 Flash Memory

MPC837xE-RDS provides 64Mbytes NOR Flash memory using general-purpose chip-select machine (GPCM). The NOR Flash is 16-bit port size in the system. It is selected as the boot Flash when J12 pins 2 and 3 are jumpered together.

## 2.1.7 I<sup>2</sup>C

The MPC837xE has two I<sup>2</sup>C interfaces. On the MPC837xE-RDS board, the MPC837xE serves as I<sup>2</sup>C master for both I<sup>2</sup>C buses (I2C1 and I2C2). I2C1 is connected to the following:

- Serial EEPROM M24256 at address 0x50.
- PCI-E and mini PCI-E socket.

The M24256 serial EEPROM can store the reset configuration word of the MPC837xE, as well as store the configuration registers values if the boot sequencer of MPC837xE is enabled. The I<sup>2</sup>C address of the M24256 EEPROM on I2C1 bus is 0x50.

## 2.1.8 SATA Controller

MPC837xE has a SATA controller for storage applications as shown in Figure 7. There are two SATA channels for MPC8377E. It requires a 100-MHz input clock, which is provided by the clock generator.

## 2.1.9 PCI Express Interface (PCI-E & Mini PCI-E)

MPC8377E supports the PCI Express (PCI-E) interface. It can be configured as two mini PCI-E interfaces or one mini PCI-E interface and one 1X PCI-E interface as shown in Figure 7. It also requires a 100-MHz input clock, which is provided by the clock generator.

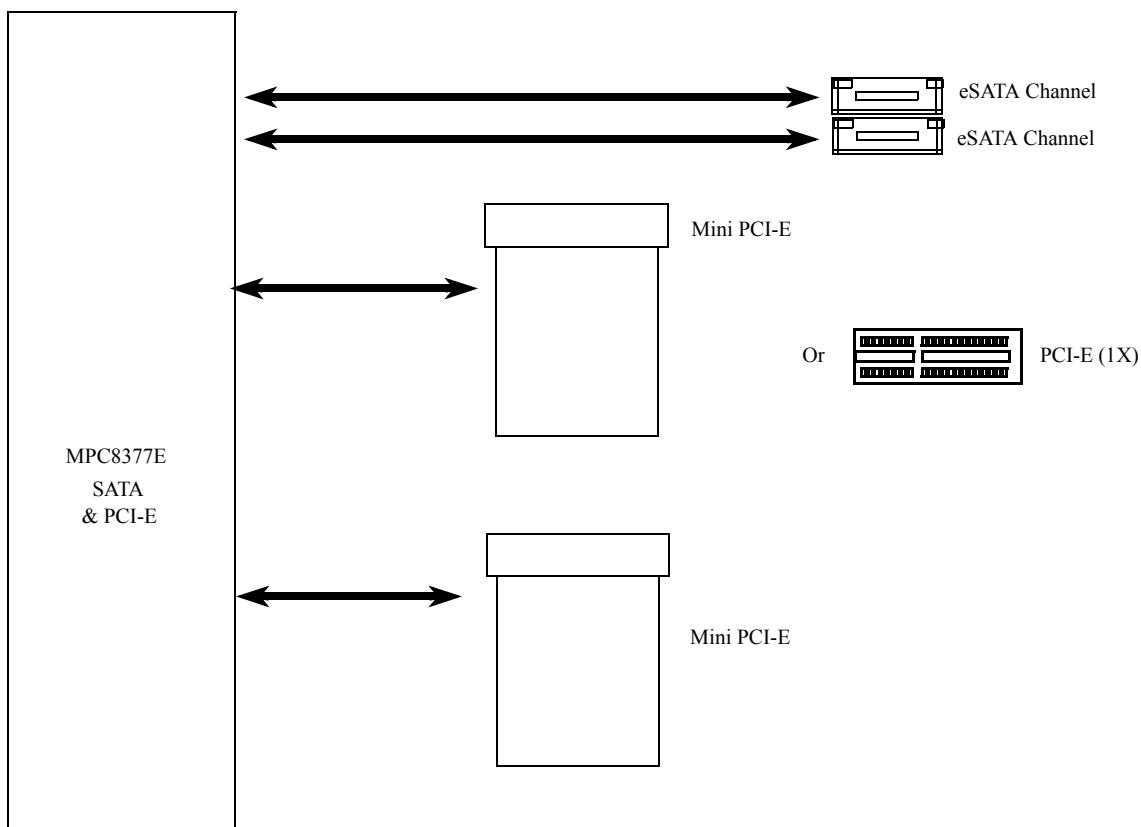

Figure 7. SATA and PCI-E Connections

## 2.1.10 10/100/1000 BaseT Interface

On the MPC837xE-RDS board, eTSEC1 and eTSEC2 use RGMII mode. The eTSEC1 and eTSEC2 drive two on-board 10/100/1000 PHYs (RTL8211B), respectively. The I/O voltage is set to 3.3 V RGMII for RTL8211B. The RGMII (1000 BaseT) is a source synchronous bus. For a transmit bus connection, it is synchronous to GTX\_CLK from the TSEC module. The receive bus connection is synchronous to RX\_CLK generated from the PHY device. The MPC837xE MII management interface also connects to



the RTL8211B. Figure 8 shows the connection between the MPC837xE eTSEC1 and eTSEC2 to the RTL8211B.

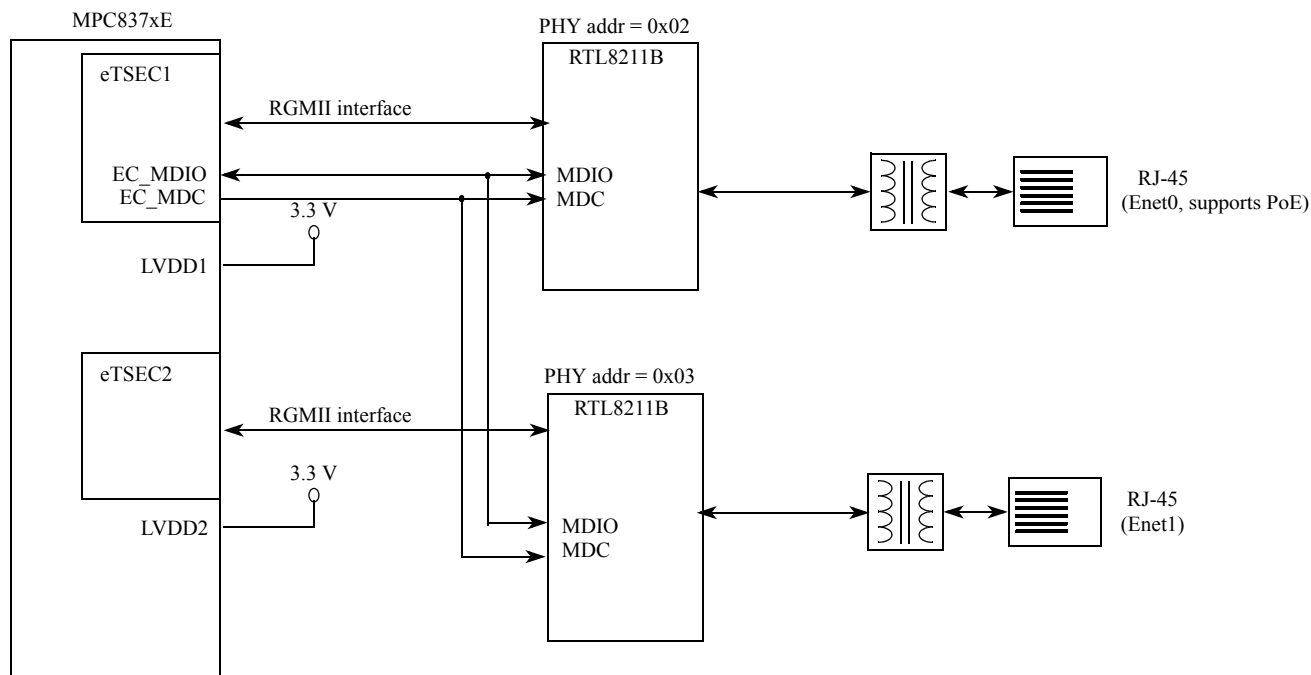

Figure 8. RGMII Interface Connection for 10/100/1000 BaseT Ethernet

### 2.1.11 RS-232 Port

Figure 9 illustrates the serial port connection using a SP3232 3.3 V RS-232 driver to interface with a 2 x 5 Header. This serial connection runs at up to 115.2 Kbps.

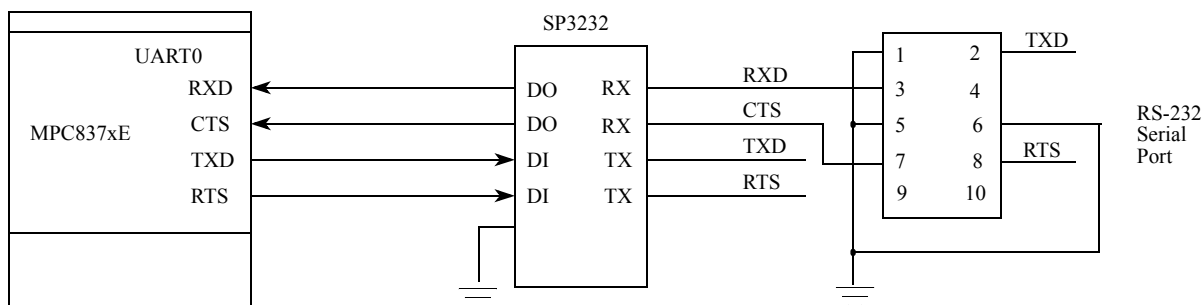

Figure 9. UART Debug Port Connection

### 2.1.12 USB 2.0 Interface

The MPC837xE has a internal USB modules (dual-role (DR) module). On the MPC837xE-RDS board, it connects to the USB PHY (USB3300) through the 8-bit UTMI low-pin-count interface (ULPI). The

USB3300 PHY connects to a Type A receptacle connector that serves as a host interface. Figure 10 shows the connection of USB.

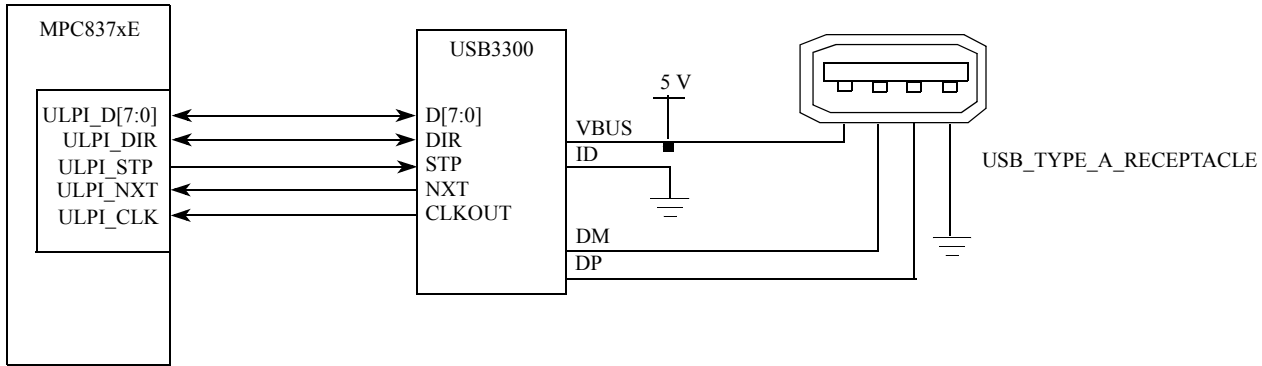

Figure 10. USB Port Connections

### 2.1.13 PCI Subsystem

The MPC837xE has PCI interfaces. It connects to two 32-bit 3.3 V mini PCI slots, as shown in Figure 11.

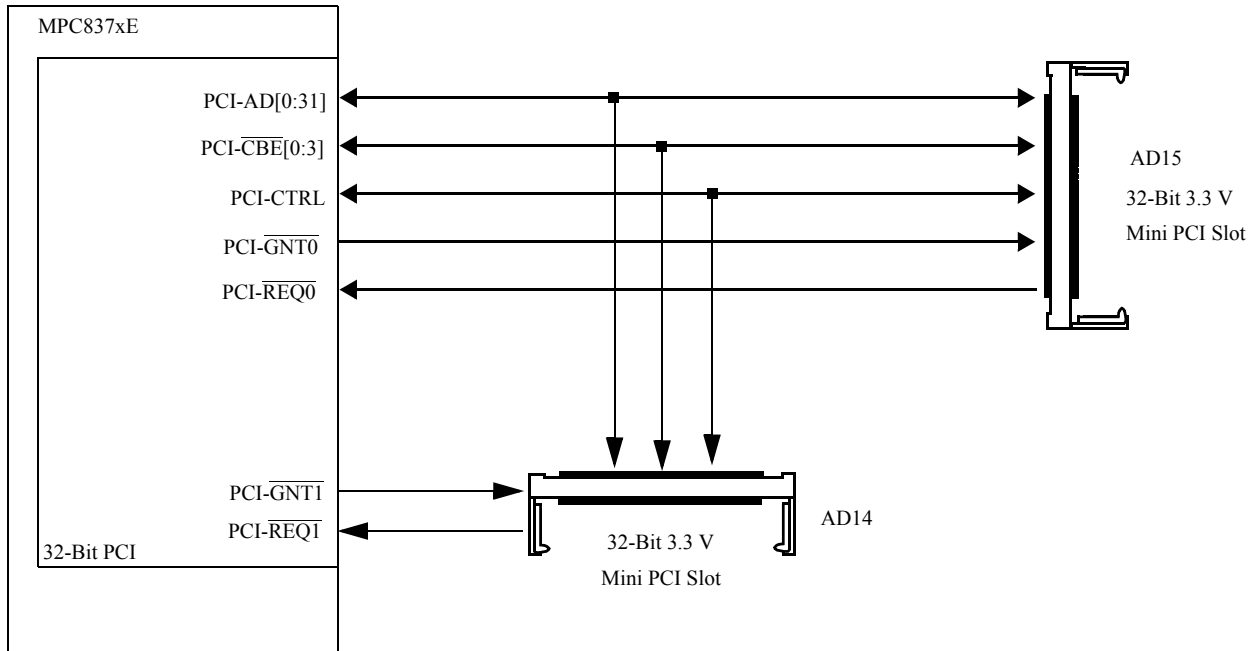
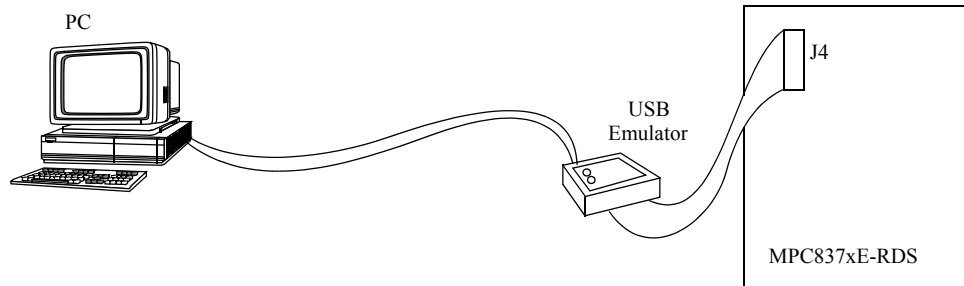

Figure 11. PCI Subsystem

### 2.1.14 COP/JTAG Port

The common on-chip processor (COP) is part of the MPC837xE JTAG module and is implemented as a set of additional instructions and logic. This port can connect to a dedicated emulator for extensive system debugging. Several third-party emulators in the market can connect to the host computer through the

Ethernet port, USB port, parallel port, RS-232, etc. [Figure 12](#) shows a typical setup using a USB port emulator.



**Figure 12. Connecting the MPC837xE-RDS Board to a Parallel Emulator**

The 16-pin generic header connector carries the COP/JTAG signals and the additional signals for system debugging. [Figure 13](#) shows the connector pinout.

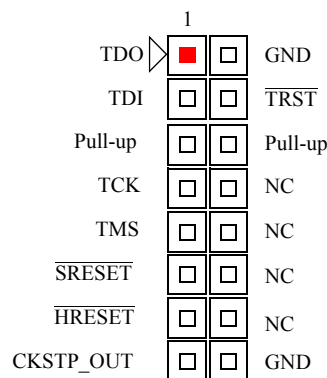

**Figure 13. MPC837xE-RDS Board COP Connector**

## 2.2 MPC837xE-RDS Assembly

Figure 14 shows the MPC837xE-RDS board top view, with the references of LEDs, jumpers, headers, and switches.

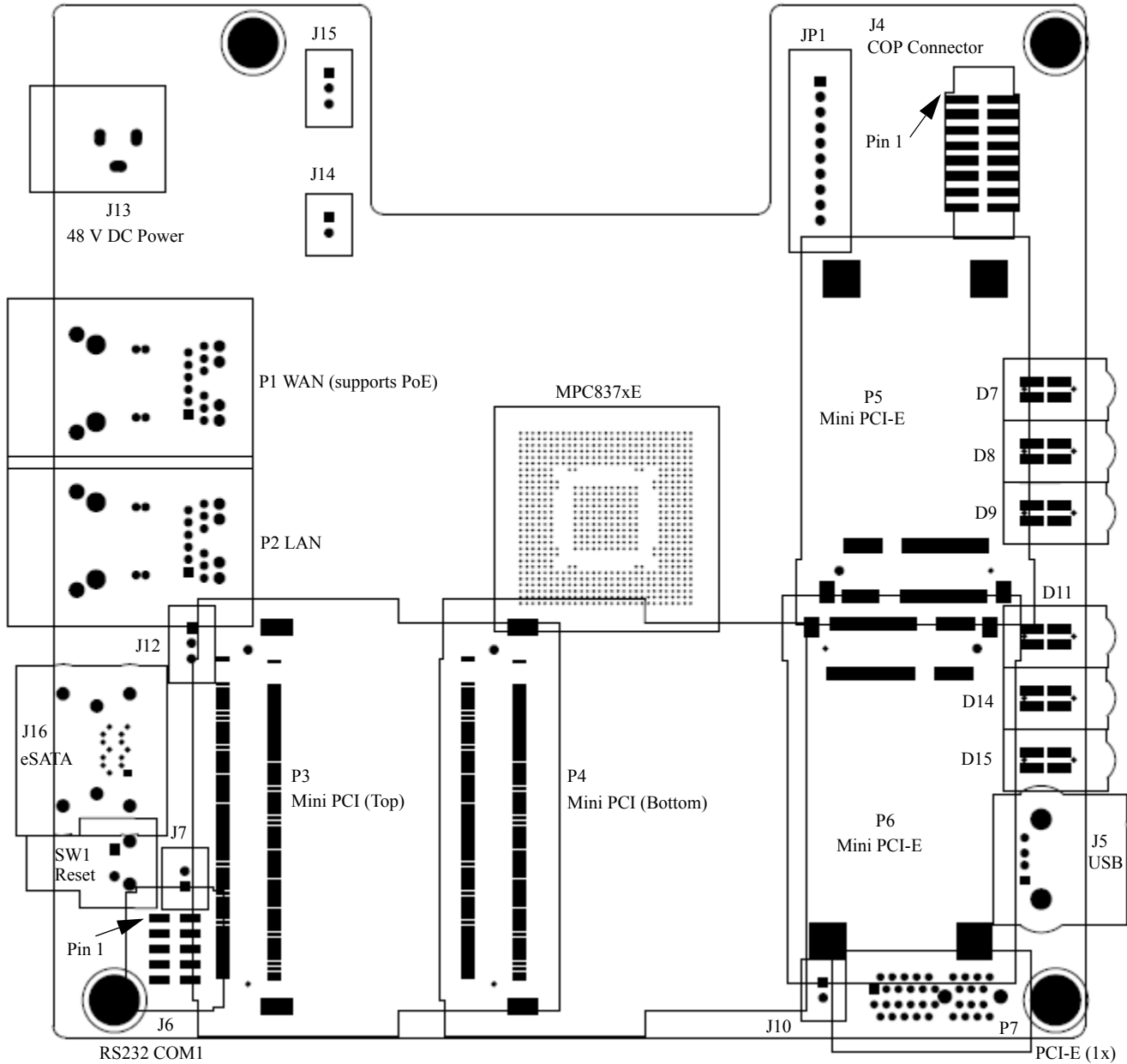

Figure 14. MPC837xE-RDS Top View

### CAUTION

Use 3.3 V mini PCI cards only for mini PCI slots. Power down before insertion or removal.

Figure 15 shows the MPC837xE-RDS board bottom view.

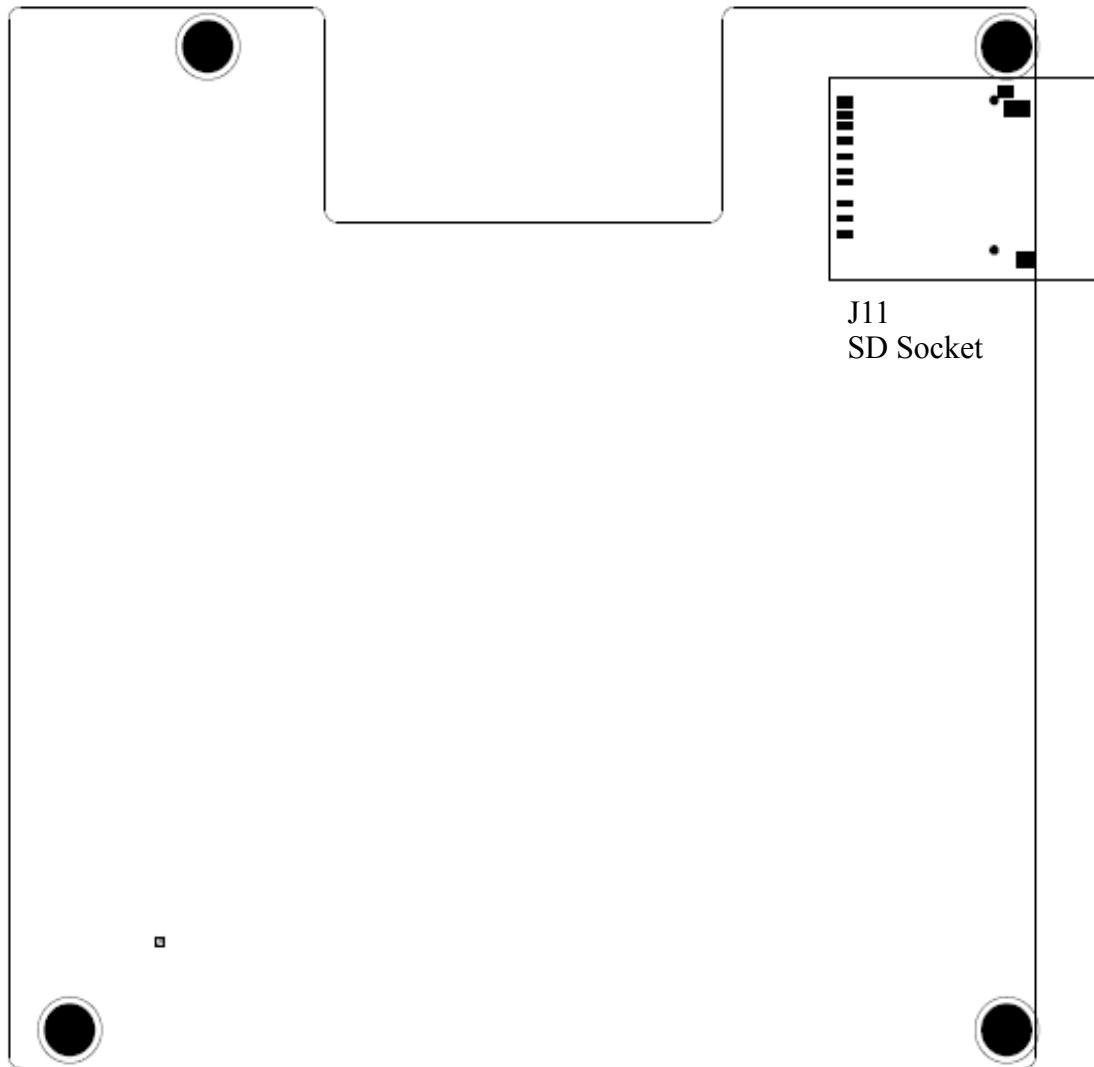

Figure 15. MPC837xE-RDS Bottom View

Table 2 shows references and descriptions of LEDs, jumpers, headers, and switches.

Table 2. Lists of Connectors, Jumpers, Switches, and LEDs

Reference	Description
<b>Connectors</b>	
J4	16-pin COP/JTAG connector

**Table 2. Lists of Connectors, Jumpers, Switches, and LEDs (continued)**

Reference	Description
P3, P4	32-bit 3.3 V mini PCI connector slots. The board supports up to 2 mini PCI devices.
J5	USB Type A receptacle (for USB high-speed external device)
J13	48 V DC power jack (external power adapter input)
J16	Double-eSATA port
J6	COM1 serial port terminal connector (RS-232C) for MPC837xE
P5, P6	Mini PCI-E connectors
P7	PCI-E (1X) connector
P1	RJ-45 connector Enet0 (Gbit Ethernet port that connects to Ethernet Switch). Enet0 is the WAN connector and supports PoE.
P2	RJ-45 connector Enet1 (Gbit Ethernet port that connects to external device). Enet1 is the LAN connector.
J11	SD Card socket
<b>Jumpers (Refer to Table 10)</b>	
<b>Switches</b>	
SW1	System reset button. Resets the MPC837xE-RDS board.
<b>LEDs (See also Section 2.4, LEDs)</b>	
D11, D14	Controlled by the GPIO pin of MPC837xE.
D7, D8, D9	eTSEC1 Eth0 link10, link100, link1000 LEDs (top) eTSEC2 Eth1 link10, link100, link1000 LEDs (bottom)
D15	3.3 V Active (Power is on if lit, and 3.3 V power is good.)

## 2.3 Connectors

This section describes the MPC837xE-RDS connectors and their pin assignments.

### 2.3.1 COP Connector

The COP connector (J4) allows the user to connect a COP/JTAG-based debugger to the MPC837xE-RDS board for debugging. [Table 3](#) lists the pin assignments of the COP connector.

**Table 3. COP Connector Pin Assignments**

Pin	Signal	Pin	Signal
1	TDO	2	GND
3	TDI	4	$\overline{\text{TRST}}$
5	$\overline{\text{QREQ}}$	6	VDD_SENSE
7	TCK	8	$\overline{\text{CHKSTOP\_IN}}$

**Table 3. COP Connector Pin Assignments**

Pin	Signal	Pin	Signal
9	TMS	10	NC
11	$\overline{\text{SRESET}}$	12	NC
13	$\overline{\text{HRESET}}$	14	NC
15	$\overline{\text{CHKSTOP\_OUT}}$	16	GND

### 2.3.2 RS-232C Connectors

Serial interface COM1 is available at connector (J6) with pin assignments as shown in [Table 4](#).

**Table 4. COM1 Connector Pins**

Pin	Signal
1	GND
2	TXD
3	RXD
4	NC
5	GND
6	GND
7	CTS
8	RTS
9	NC
10	NC

### 2.3.3 Serial ATA (SATA) Connector

The Double-eSATA connector (J16) connects to the serial ATA hard disks through eSATA cables.

### 2.3.4 Mini PCI Connector

The board has two mini-PCI connectors (P3, P4) for plugging in mini PCI cards. [Figure 16](#) shows how to plug a mini PCI card into the board.

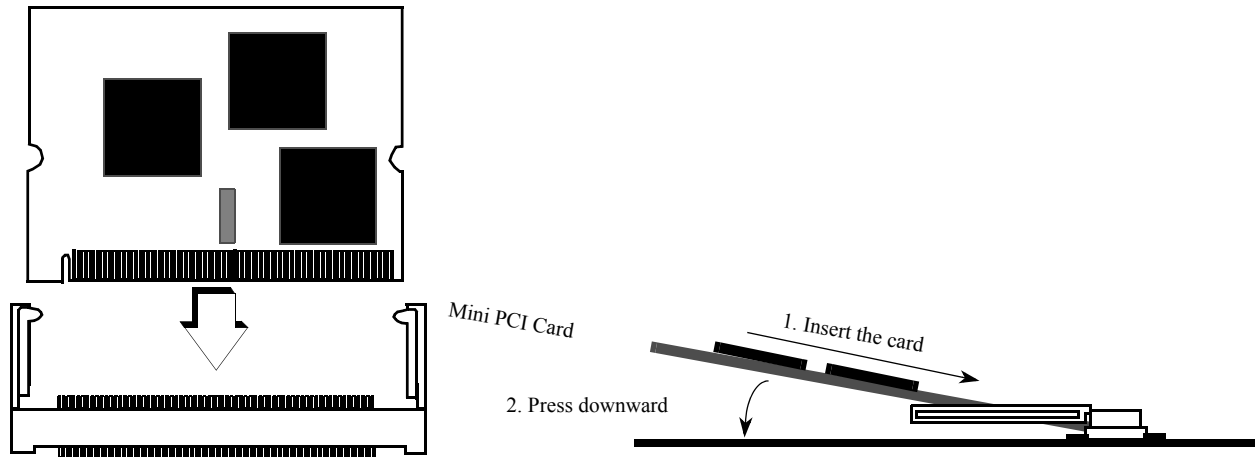

Figure 16. Installation of a Mini PCI Card

### 2.3.5 Power Connector

J13 is a DC jack for a 48 V power supply to the MPC837xE-RDS board.

## 2.4 LEDs

Figure 17 shows 9 LED indicators on the front panel of MPC837xE-RDS.

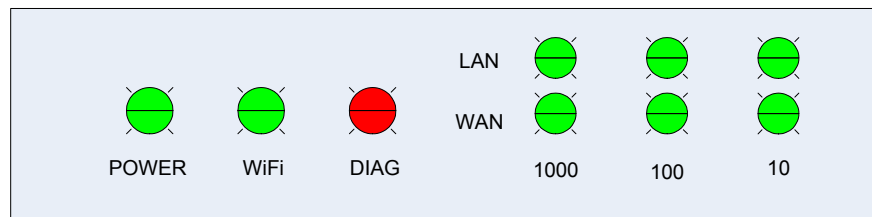

Figure 17. LED Indicators on the Front Panel of MPC837xE-RDS

### 2.4.1 Power-on LED

Green Power LED (D15): indicates the system is power-on if lit.

### 2.4.2 RDS Programmable LEDs

Green WiFi LED (D14): indicates whether the WiFi Card is inserted and activated (SW not implemented yet). GPIO1[10] controls this LED. Writing 0 turns on the LED, and writing 1 turns off the LED.

Red DIAG LED (D11): indicates the status of diagnostics for MPC837xE-RDS board. The LED is flashing when system is going through the diagnostics. It is on if the system finds some problems during the diagnostics. And it is off if the system passes the diagnostics (SW not implemented yet). GPIO1[9] controls this LED. Writing 0 turns on the LED, and writing 1 turns off the LED.



### 2.4.3 Ethernet LEDs

Green Link1000 LEDs (D9): indicate the link speed is 1000M on WAN and LAN. (The top LED for LAN and the bottom one for WAN)

Green Link100 LEDs (D8): indicate the link speed is 100M on WAN and LAN. (The top LED for LAN and the bottom one for WAN)

Green Link10 LEDs (D7): indicate the link speed is 10M on WAN and LAN. (The top LED for LAN and the bottom one for WAN)

## 2.5 MPC837xE-RDS Board Configuration

This section describes the operational mode and configuration options of the MPC837xE-RDS board.

### 2.5.1 EEPROM

The MPC837xE-RDS board has an on-board serial EEPROM. MPC837xE acts as I<sup>2</sup>C master and it is connected to the M24256 serial EEPROM using I2C1 as shown in [Figure 18](#).

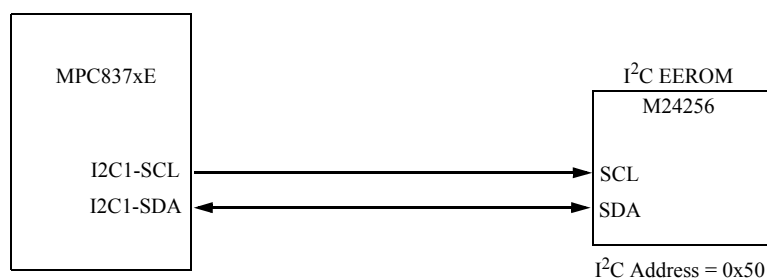

**Figure 18. I2C EEPROM**

You can use the M24256 serial EEPROM to store the reset configuration word of the MPC837xE, as well as store the configuration registers' values and user program if the boot sequencer of MPC837xE is enabled.

For more details about programming the reset configuration word value in I<sup>2</sup>C EEPROM and the boot sequencer mode, refer to the MPC8379ERM. The I<sup>2</sup>C address of the M24256 EEPROM on the bus is 0x50.

### 2.5.2 PCI Operating Frequency

An M66EN input pin determines the AC timing of the PCI interface. On the MPC837xE-RDS board, the PCI agent card—connected to a mini PCI slot—determines the M66EN signal level. If a 33-MHz-only card is inserted, the M66EN signal is driven to 0 by the PCI agent card according to the PCI specification, or it is driven to 1 if it can perform at 66 MHz. A NOT gate inverts the signal and drives the CFG\_CLKIN\_DIV input pin so the system clock continues at the same frequency.

### 2.5.3 Reset Configuration Word

The reset configuration word (RCW) controls the clock ratios and other basic device functions, such as PCI host or agent mode, boot location, TSEC modes, and endian mode. The reset configuration word is divided into reset configuration word lower (RCWL) and reset configuration word higher (RCWH) and is loaded from the local bus during the power-on or hard reset flow. The default RCW low-bit setting is 0x0404\_0000. The default RCW high-bit setting is 0xA060\_6C02.

The RCW is located at the lowest 64 bits of the boot Flash memory, which is 0xFC00\_0000 on this board.

**Table 5. RCW Configuration in Flash Memory**

Address				
FC000000:	26262626	26262626	03030303	03030303
FC000010:	00000000	00000000	00000000	00000000
FC000020:	A0A0A0A0	A0A0A0A0	60606060	60606060
FC000030:	6C6C6C6C	6C6C6C6C	02020202	02020202

Figure 19 and Figure 20 show the RCW definitions.

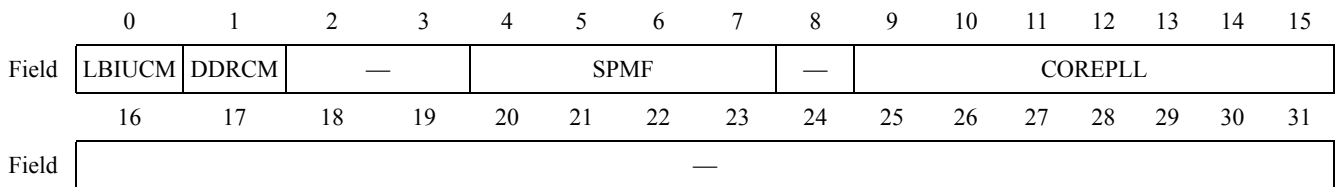

**Figure 19. Reset Configuration Word Low (RCWL) Bit Settings**

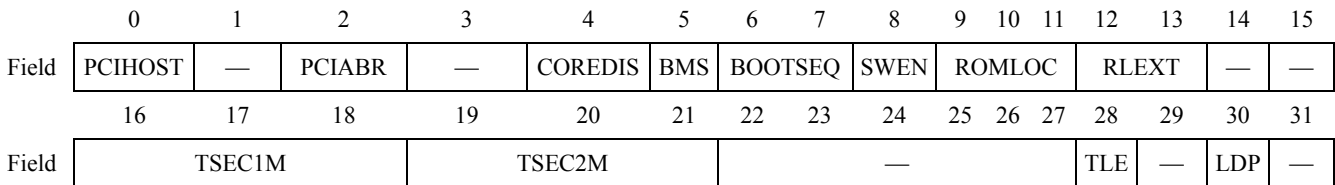

**Figure 20. Reset Configuration Word High (RCWH) Bit Settings**

**Table 6. RCWL Bit Descriptions**

Bits	Name	Meaning	Description	
0	LBIUCM	Local bus memory controller clock mode	Local Bus Controller Clock: CSB_CLK	
			0: Default	ratio 1:1
			1:	ratio 2:1
1	DDRCM	DDR SDRAM memory controller clock mode	DDR Controller Clock: CSB_CLK	
			0: Default	ratio 1:1
			1:	ratio 2:1

Table 6. RCWL Bit Descriptions (continued)

Bits	Name	Meaning	Description	
2–3	—	Reserved	Should be cleared.	
4–7	SPMF[0–3]	System PLL multiplication factor	0000	16:1
			0001	Reserved
			0010	2:1
			0011	3:1
			0100 (default)	4:1
			0101	5:1
4–7	SPMF[0–3]	System PLL multiplication factor	0110	6:1
			0111	7:1
			1000	8:1
			1001	9:1
			1010	10:1
			1011	11:1
			1100	12:1
			1101	13:1
			1110	14:1
			1111	15:1
8	—	Reserved	Should be cleared.	
9–15	COREPLL [0–6]	Value	coreclk: csb_clk	VCO divider
		nn 0000 n	PLL bypassed	PLL bypassed
		00 0001 0	1:1	2
		01 0001 0	1:1	4
		10 0001 0	1:1	8
		11 0001 0	1:1	8
		00 0001 1	1.5:1	2
		01 0001 1	1.5:1	4
		10 0001 1	1.5:1	8
		11 0001 1	1.5:1	8
		00 0010 0: Default	2:1	2

**Table 6. RCWL Bit Descriptions (continued)**

Bits	Name	Meaning	Description	
9–15	COREPLL [0–6]	01 0010 0	2:1	4
		10 0010 0	2:1	8
		11 0010 0	2:1	8
		00 0010 1	2.5:1	2
		01 0010 1	2.5:1	4
		10 0010 1	2.5:1	8
		11 0010 1	2.5:1	8
		00 0011 0	3:1	2
		01 0011 0	3:1	4
		10 0011 0	3:1	8
		11 0011 0	3:1	8
16–31	—	Reserved.	Should be cleared.	

**Table 7. Reset Configuration Word High (RCWH) Bit Descriptions**

Bits	Name	Meaning	Detailed Description	
0	PCIHOST	PCI host mode	0	PCI agent
			1: Default	PCI host
1	Reserved	—	Should be cleared	
2	PCIARB	PCI arbiter	0	PCI arbiter disabled
			1: Default	PCI arbiter enabled
3	Reserved	—	Should be cleared	
4	COREDIS	Core disable mode	0: Default	e300 enabled
			1	e300 disabled
5	BMS	Boot memory space	0: Default	0x0000_0000–0x007F_FFFF
			1	0xFF80_0000–0xFFFF_FFFF
6–7	BOOTSEQ	Boot sequencer configuration	00: Default	Boot sequencer is disabled
			01	Boot sequencer load configuration from I <sup>2</sup> C
			10	Boot sequencer load configuration from EEPROM
			11	Reserved
8	SWEN	Software watchdog enable	0: Default	Disabled
			1	Enabled

Table 7. Reset Configuration Word High (RCWH) Bit Descriptions (continued)

Bits	Name	Meaning	Detailed Description	
9–11	ROMLOC	Boot ROM interface location	000	DDR SDRAM
			001	PCI1
			010	Reserved
			011	On-chip Boot ROM
			100	Reserved
			101	Local bus GPCM, 8 bits
			110: Default	Local bus GPCM, 16 bits
			111	Local bus GPCM, 32 bits
12–13	RLEXT	Boot ROM location extension	00: Default	Legacy mode
			01	NAND Flash mode
			10	Reserved
			11	Reserved
14–15	Reserved	—	Should be cleared	
16–18	TSEC1M	TSEC1 Mode	000	MII
			001	RMII
			010	Reserved
			011: Default	RGMII
			100	Reserved
			101	RTBI
			110	SGMII
			110	Reserved
19–21	TSEC2M	TSEC2 Mode	000	MII
			001	RMII
			010	Reserved
			011: Default	RGMII
			100	Reserved
			101	RTBI
			110	SGMII
			110	Reserved
22–27	Reserved	—	Should be cleared	
28	TLE	True little endian	0: Default	Big-endian mode
			1	True little endian mode
29	Reserved	—	Should be cleared	

**Table 7. Reset Configuration Word High (RCWH) Bit Descriptions (continued)**

Bits	Name	Meaning	Detailed Description	
30	LDP	LDP/CKSTP pin mux state after reset	0	LDP[0:3] = local data parity.
			1: Default	LDP[0:3] = $\overline{\text{LCS}}[4:7]$
31	Reserved	—	Should be cleared	

## 2.5.4 Power Supply

The MPC837xE requires a 48 V power supply from the DC power jack or PoE for normal operation. The 48 V power supply is reduced to 5 V and 3.3 V from the DC-DC circuitry on PoE daughter board. The 1.0 V, 1.5 V, and 1.8 V are all generated from switching regulators. The 1.0 V power is for a CPU core. The 1.5 V and 1.8 V powers are for two GE PHYs and two mini PCI-E connectors. The 1.8 V power is also for the DDR controller.

## 2.5.5 Chip-Select Assignments and Memory Map

Table 8 shows an example memory map on the MPC837xE that is used for u-boot in the Flash memory.

**Table 8. Example Memory Map, Local Access Window, and Chip-Select Assignments**

Address Range	Target Interface	Chip-Select Line	Device Name	Port Size (Bits)
0x0000_0000–0x1FFF_FFFF	DDR	MCS0	DDR2 SDRAM (512 Mbyte)	64
0x8000_0000–0x9FFF_FFFF	PCI1	Nil	PCI1 memory space (512 Mbyte)	32
0xE200_0000–0xE2FF_FFFF	PCI1	Nil	PCI1 I/O space (16 Mbyte)	32
0xA000_0000–0xBFFF_FFFF	PCI2	Nil	PCI2 memory space (512 Mbyte)	32
0xE300_0000–0xE3FF_FFFF	PCI2	Nil	PCI2 I/O space (16 Mbyte)	32
0xE000_0000–0xEFFF_FFFF	Internal bus	Nil	IMMR (1 Mbyte)	—
0xFC00_0000–0xFFFF_FFFF	Local bus	LCS0	NOR Flash memory (64 Mbyte)	16

## 2.6 Specifications

Table 9 lists the specifications of the MPC837xE-RDS board.

**Table 9. MPC837xE-RDS Board Specifications**

Characteristics	Specifications						
Power requirements: (Without any plugin card and USB device)	<table> <tr> <td></td> <td><b>Typical</b></td> </tr> <tr> <td>5.0 V DC</td> <td>0.009 A</td> </tr> <tr> <td>3.3 V DC</td> <td>1.17 A</td> </tr> </table>		<b>Typical</b>	5.0 V DC	0.009 A	3.3 V DC	1.17 A
	<b>Typical</b>						
5.0 V DC	0.009 A						
3.3 V DC	1.17 A						
Communication processor	MPC8377E running @ up to 667 MHz						

Table 9. MPC837xE-RDS Board Specifications (continued)

Characteristics	Specifications
Addressing: Total address range Flash memory (local bus) DDR SDRAM	4 Gbyte (32 address lines) 64 Mbyte NOR Flash 512 Mbyte DDR2 SDRAM at DDR400
Operating temperature	0°C to 70°C (room temperature)
Storage temperature	-25°C to 85°C
Relative humidity	5% to 90% (noncondensing)
PCB dimensions: Length Width Thickness	6693 mil 6693 mil 67 mil

## 2.7 Mechanical Data

Figure 21 shows the MPC837xE-RDS dimensions (in mil). The board dimensions are 170 mm × 170 mm (6693 mils × 6693 mils) for integration in a mini ITX chassis with a small footprint.

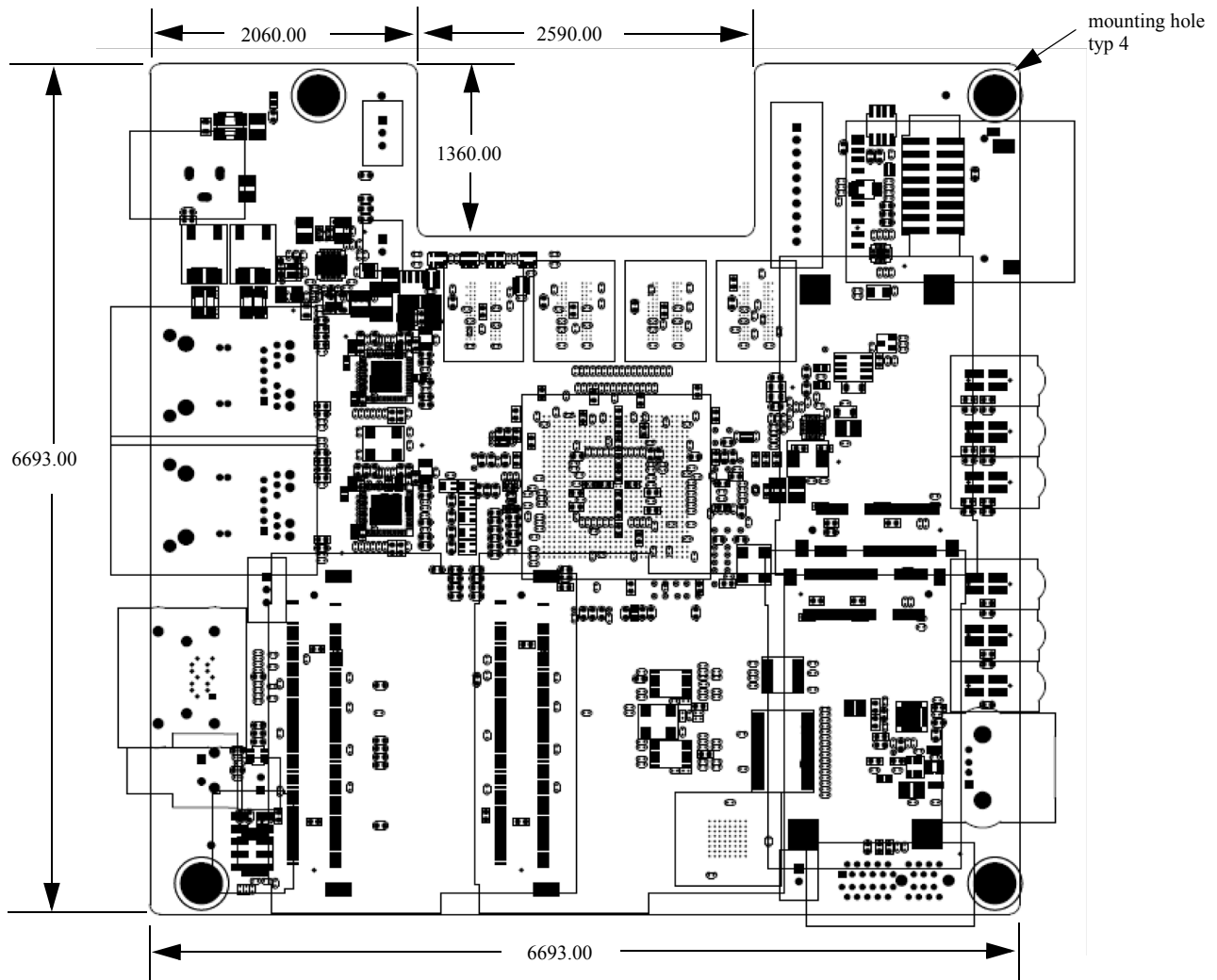

Figure 21. Dimensions of the MPC837xE-RDS Board

## 3 Board Bootup

This section describes how to boot up the MPC837xE-RDS board. The factory has preloaded a Flash image onto the on-board Flash memory. Before powering up the board, set the on-board jumpers according to the settings listed in [Section 3.1, Board Jumper Settings](#).



**CAUTION**

Avoid touching areas of circuitry and connectors; static discharge can damage circuits.

### 3.1 Board Jumper Settings

Figure 22 shows a partial top view of the MPC837xE-RDS with red outlines at jumper designators J7, J10, and J12. A square pad indicates pin 1 of the part. Table 10 shows the default jumper settings.

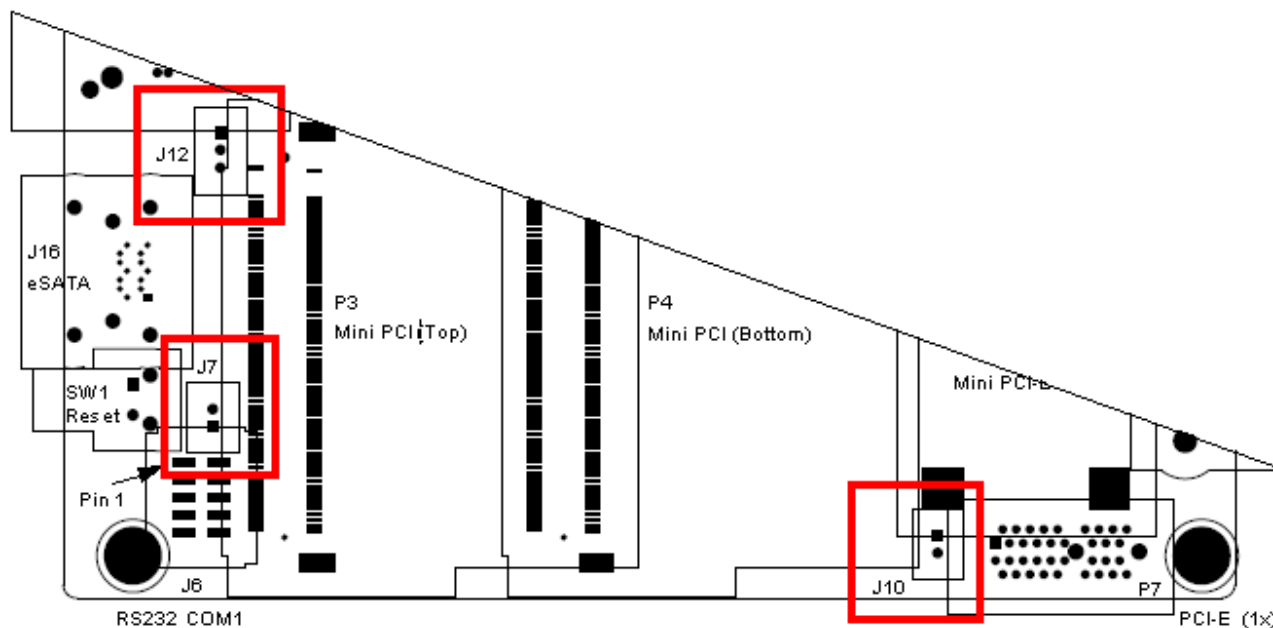

Figure 22. Partial MPC837xE-RDS Top View

Table 10. Default Jumper Settings

Reference	Default Jumper Setting	√ = Jumper × = No Jumper	Description
J7		×	Watchdog input for MAX6829. Default is no jumper.
J10		×	12V external power input for optional connector---X1 PCI Express.
J12	2-3	√	Select the reset configuration source (RST-CFG-SRC) for the MPC837xE. Jumper 2-3 (default): 0000 Reset configuration word is loaded from NOR Flash. Jumper 1-2: 1111 Hard-coded option 7. Reset configuration word is not loaded.

## 3.2 External Connections

Figure 23 shows the external connections.

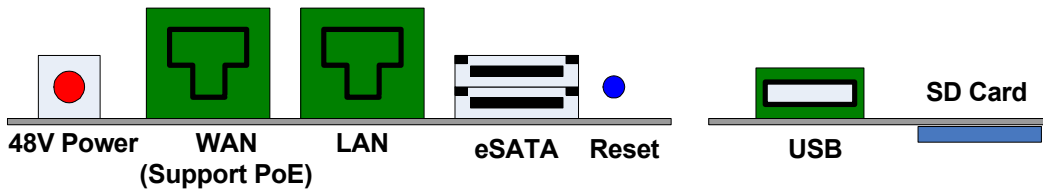

Figure 23. External Connections

### NOTE

Strong electromagnetic interference might disturb the normal function of the product. If so, simply reset the product to resume normal operation by following the steps in the software user guide. If normal function does not return, please move the product to another location.

## 4 MPC837xE-RDS Software

The MPC837xE-RDS comes with a pre-installed reference design software package. This package consists of a bootloader (u-boot), a generic PPC Linux-based system, and a suite of Wi-Fi router applications. The software all resides in the on-board Flash memory. Upon powerup, the Linux system and the applications run on the MPC837xE-RDS.

The MPC837xE-RDS reference software takes advantage of a tool called OpenWRT, a Linux platform for embedded devices. Instead of trying to create a single, static firmware, OpenWrt provides a fully writable file system with package management. This frees you from the application selection and configuration, allowing you to customize the device through the use of packages to suit any application.

### 4.1 Application Features for MPC837xE-RDS reference software

The pre-installed reference design software supports the application of the Wi-Fi router, including the following:

- 802.11 a/b/g/n
- IPv4 and IPv6
- DHCP
- DNS
- VLAN
- NAT and PAT
- Static routing
- RIP v1, v2
- VRRP

- PPPoE
- IGMP
- UPnP
- SNMP
- QoS

Wireless Security:

- Pre-Shared Key (PSK)
- Wi-Fi Protected Access 2 (WPA2)
- 802.11i AES-CCMP
- Wired Equivalent Privacy (WEP), 128/256-bit
- 802.11i EAP authentication with RADIUS

Network Security:

- Access control
- Stateful packet inspection firewall
- Intrusion detection
- Content filtering

Virtual Private Network (VPN):

- IPSec
- PPTP
- L2TP

## 4.2 Application Connections

Figure 24 shows application connections for MPC837xE-RDS board.

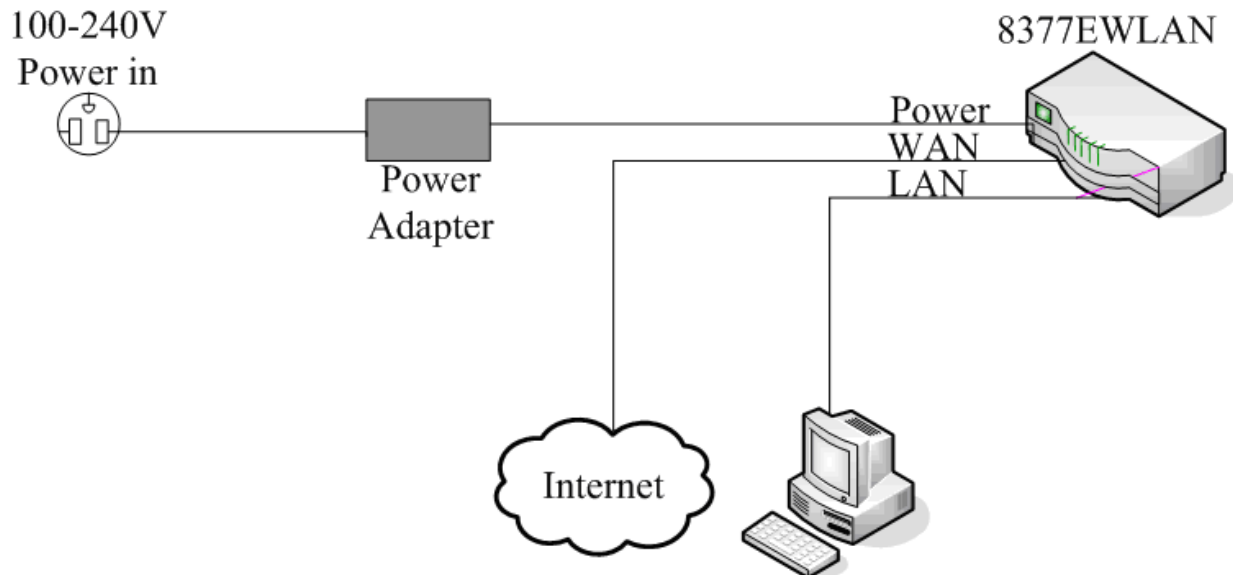

Figure 24. MPC837xE-RDS Application Connections

Configure the MPC837xE-RDS board by using a web browser. Connect your PC to the LAN port of the board (either directly or through a hub), then use a web browser to configure. TCP/IP settings must be correct. The TCP/IP setting should be on the IP subnet of the MPC837xE-RDS.

- Set up the IP Address automatically:
  - MPC837xE-RDS incorporates a DHCP server. The easiest method is to set your PC to get its IP address automatically and correctly obtain the correct IP address, gateway, and DNS.
- Set up the IP Address manually:
  - The default IP address of MPC837xR-RDS reference board is 192.168.1.1/24. Set the IP address of the PC as 192.168.1.xxx/24, where xxx can be any number between 2 and 254, and the set the default gateway to 192.168.1.1.

After setting the IP address, open a web browser and type address <http://192.168.1.1>. At the login window, type `admin` for both User name and Password. You will then arrive at the MPC837xR-RDS main page. After that, you can review and modify the configuration as needed. For more information, refer to the software user guide.

Besides acting as one Wi-Fi router, MPC837xE-RDS platform can also support other utilities and applications. For details of different applications for MPC837xE-RDS, contact your local Freescale sales office.

## 5 Unit Assembly

The assembled unit is composed of the board assembly, an enclosure, screws, and other parts. The instructions in this section apply if you need to assemble or reassemble the product or add peripherals mentioned.

### 5.1 Assembling the Enclosure and Board Assembly

Assembling the board into the enclosure requires screwing the board onto the base, then screwing the top and base together.

1. Place the base on a flat surface.
2. Set the board assembly in the base so the connectors and LEDs fit perfectly and the board's mounting holes align with the base's mating holes.
3. With four screws and washers, screw the board to the base.
4. Align the top with the base, with the Freescale logo nearest the rear panel (connector side).
5. Screw the parts together from the bottom side of the base using four screws.

### 5.2 Attaching a Wi-Fi Card to the Product

Attaching the Wi-Fi card to the product requires separating the top of the enclosure from the unit, plugging a Wi-Fi card into a mini PCI slot, installing the antenna cable into the Wi-Fi card, then reassembling the the product.

#### CAUTION

Use a 3.3 V mini PCI card only. Power down before insertion or removal.

1. From the bottom of the assembled unit, remove the four screws.
2. Turn the unit right side up, plug in the Wi-Fi card, then latch it. See [Figure 16](#) for positioning depiction.
3. Install the antenna cable into the Wi-Fi card connector, then select the proper holes on the panel (4 on rear panel and 2 on front panel) to position the antenna.
4. Re-assemble using Steps 4 and 5 of [Section 5.1, Assembling the Enclosure and Board Assembly](#).

### 5.3 Attaching a SATA hard disk to the Product

Attaching a SATA hard disk to the product requires disassembling the unit into the enclosure top and bottom and the board assembly, inserting the hard disk, installing the cable, then re-assembling the product.

1. Disassemble the entire unit.
2. Plug the SATA cable to J11 at the bottom side of PCBA.
3. Release the hard disk tray on the enclosure base, then position the hard disk in it.
4. Plug the other end of the SATA cable to hard disk, then position the tray in the base.

---

## Unit Assembly

5. Re-assemble using Steps 2 through 5 of [Section 5.1, Assembling the Enclosure and Board Assembly](#).