

10 kPa Uncompensated Silicon Pressure Sensors

The MPX10 and MPXV10GC series devices are silicon piezoresistive pressure sensors providing a very accurate and linear voltage output — directly proportional to the applied pressure. These standard, low cost, uncompensated sensors permit manufacturers to design and add their own external temperature compensation and signal conditioning networks. Compensation techniques are simplified because of the predictability of Motorola's single element strain gauge design. Figure 1 shows a schematic of the internal circuitry on the stand-alone pressure sensor chip.

Features

- Low Cost
- Patented Silicon Shear Stress Strain Gauge Design
- Ratiometric to Supply Voltage
- Easy to Use Chip Carrier Package Options
- Differential and Gauge Options
- Durable Epoxy Unibody Element or Thermoplastic (PPS) Surface Mount Package

Application Examples

- Air Movement Control
- Environmental Control Systems
- Level Indicators
- Leak Detection
- Medical Instrumentation
- Industrial Controls
- Pneumatic Control Systems
- Robotics

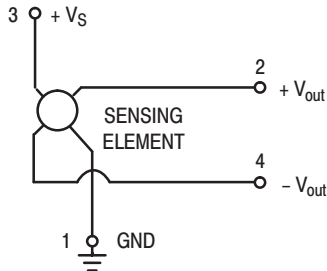

Figure 1. Uncompensated Pressure Sensor Schematic

VOLTAGE OUTPUT versus APPLIED DIFFERENTIAL PRESSURE

The output voltage of the differential or gauge sensor increases with increasing pressure applied to the pressure side (P1) relative to the vacuum side (P2). Similarly, output voltage increases as increasing vacuum is applied to the vacuum side (P2) relative to the pressure side (P1).

MPX10 MPXV10GC SERIES

0 to 10 kPa (0–1.45 psi)
35 mV FULL SCALE SPAN
(TYPICAL)

SMALL OUTLINE PACKAGE

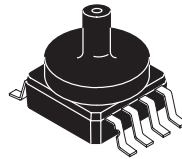

MPXV10GC6U
CASE 482A

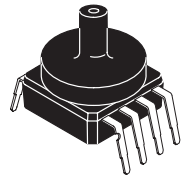

MPXV10GC7U
CASE 482C

PIN NUMBER

1	Gnd	5	N/C
2	+V _{out}	6	N/C
3	V _s	7	N/C
4	-V _{out}	8	N/C

NOTE: Pin 1 is noted by the notch in the lead.

UNIBODY PACKAGE

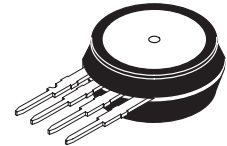

MPX10D
CASE 344

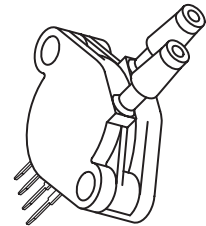

MPX10DP
CASE 344C

PIN NUMBER

1	Gnd	3	V _s
2	+V _{out}	4	-V _{out}

NOTE: Pin 1 is noted by the notch in the lead.

MPX10 MPXV10GC SERIES

MAXIMUM RATINGS(NOTE)

Rating	Symbol	Value	Unit
Maximum Pressure (P1 > P2)	P_{max}	75	kPa
Burst Pressure (P1 > P2)	P_{burst}	100	kPa
Storage Temperature	T_{stg}	-40 to +125	°C
Operating Temperature	T_A	-40 to +125	°C

NOTE: Exposure beyond the specified limits may cause permanent damage or degradation to the device.

OPERATING CHARACTERISTICS ($V_S = 3.0$ Vdc, $T_A = 25^\circ\text{C}$ unless otherwise noted, P1 > P2)

Characteristic	Symbol	Min	Typ	Max	Unit
Differential Pressure Range ⁽¹⁾	P_{OP}	0	—	10	kPa
Supply Voltage ⁽²⁾	V_S	—	3.0	6.0	Vdc
Supply Current	I_o	—	6.0	—	mAdc
Full Scale Span ⁽³⁾	V_{FSS}	20	35	50	mV
Offset ⁽⁴⁾	V_{off}	0	20	35	mV
Sensitivity	$\Delta V/\Delta P$	—	3.5	—	mV/kPa
Linearity ⁽⁵⁾	—	-1.0	—	1.0	% V_{FSS}
Pressure Hysteresis ⁽⁵⁾ (0 to 10 kPa)	—	—	± 0.1	—	% V_{FSS}
Temperature Hysteresis ⁽⁵⁾ (-40°C to +125°C)	—	—	± 0.5	—	% V_{FSS}
Temperature Coefficient of Full Scale Span ⁽⁵⁾	TCV_{FSS}	-0.22	—	-0.16	% $V_{FSS}/^\circ\text{C}$
Temperature Coefficient of Offset ⁽⁵⁾	TCV_{off}	—	± 15	—	$\mu\text{V}/^\circ\text{C}$
Temperature Coefficient of Resistance ⁽⁵⁾	TCR	0.28	—	0.34	% $Z_{in}/^\circ\text{C}$
Input Impedance	Z_{in}	400	—	550	Ω
Output Impedance	Z_{out}	750	—	1250	Ω
Response Time ⁽⁶⁾ (10% to 90%)	t_R	—	1.0	—	ms
Warm-Up Time ⁽⁷⁾	—	—	20	—	ms
Offset Stability ⁽⁸⁾	—	—	± 0.5	—	% V_{FSS}

NOTES:

- 1.0 kPa (kiloPascal) equals 0.145 psi.
- Device is ratiometric within this specified excitation range. Operating the device above the specified excitation range may induce additional error due to device self-heating.
- Full Scale Span (V_{FSS}) is defined as the algebraic difference between the output voltage at full rated pressure and the output voltage at the minimum rated pressure.
- Offset (V_{off}) is defined as the output voltage at the minimum rated pressure.
- Accuracy (error budget) consists of the following:
 - Linearity: Output deviation from a straight line relationship with pressure, using end point method, over the specified pressure range.
 - Temperature Hysteresis: Output deviation at any temperature within the operating temperature range, after the temperature is cycled to and from the minimum or maximum operating temperature points, with zero differential pressure applied.
 - Pressure Hysteresis: Output deviation at any pressure within the specified range, when this pressure is cycled to and from the minimum or maximum rated pressure, at 25°C.
 - TcSpan: Output deviation at full rated pressure over the temperature range of 0 to 85°C, relative to 25°C.
 - TcOffset: Output deviation with minimum rated pressure applied, over the temperature range of 0 to 85°C, relative to 25°C.
 - TCR: Z_{in} deviation with minimum rated pressure applied, over the temperature range of -40°C to +125°C, relative to 25°C.
- Response Time is defined as the time for the incremental change in the output to go from 10% to 90% of its final value when subjected to a specified step change in pressure.
- Warm-up Time is defined as the time required for the product to meet the specified output voltage after the pressure has been stabilized.
- Offset Stability is the product's output deviation when subjected to 1000 hours of Pulsed Pressure, Temperature Cycling with Bias Test.

TEMPERATURE COMPENSATION

Figure 2 shows the typical output characteristics of the MPX10 and MPXV10GC series over temperature.

Because this strain gauge is an integral part of the silicon diaphragm, there are no temperature effects due to differences in the thermal expansion of the strain gauge and the diaphragm, as are often encountered in bonded strain gauge pressure sensors. However, the properties of the strain gauge itself are temperature dependent, requiring that the device be temperature compensated if it is to be used over an extensive temperature range.

Temperature compensation and offset calibration can be achieved rather simply with additional resistive components, or by designing your system using the MPX2010D series sensor.

Several approaches to external temperature compensa-

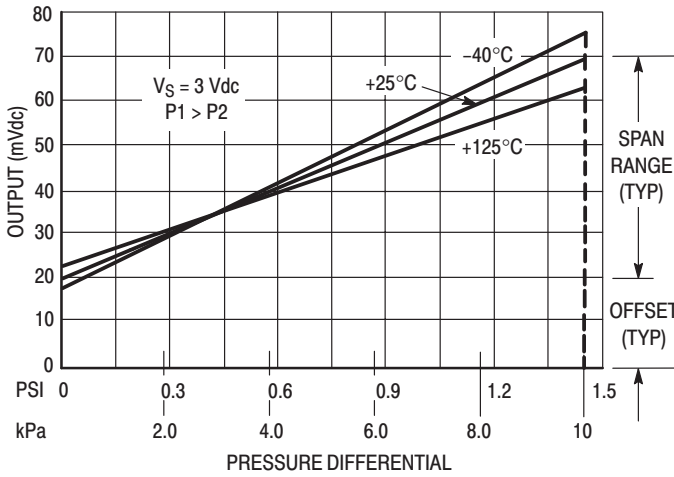

Figure 2. Output versus Pressure Differential

tion over both -40 to $+125^{\circ}\text{C}$ and 0 to $+80^{\circ}\text{C}$ ranges are presented in Motorola Applications Note AN840.

LINEARITY

Linearity refers to how well a transducer's output follows the equation: $V_{out} = V_{off} + \text{sensitivity} \times P$ over the operating pressure range (Figure 3). There are two basic methods for calculating nonlinearity: (1) end point straight line fit or (2) a least squares best line fit. While a least squares fit gives the "best case" linearity error (lower numerical value), the calculations required are burdensome.

Conversely, an end point fit will give the "worst case" error (often more desirable in error budget calculations) and the calculations are more straightforward for the user. Motorola's specified pressure sensor linearities are based on the end point straight line method measured at the midrange pressure.

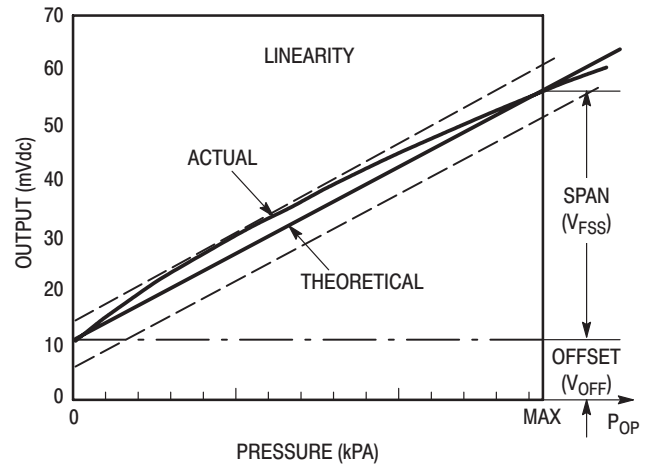

Figure 3. Linearity Specification Comparison

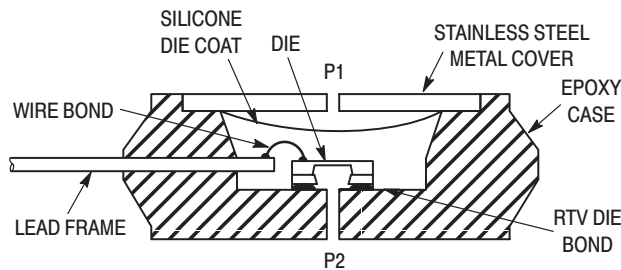

Figure 4. Unibody Package — Cross-Sectional Diagram (not to scale)

Figure 4 illustrates the differential or gauge configuration in the basic chip carrier (Case 344). A silicone gel isolates the die surface and wire bonds from the environment, while allowing the pressure signal to be transmitted to the silicon diaphragm.

The MPX10 and MPXV10GC series pressure sensor oper-

ating characteristics and internal reliability and qualification tests are based on use of dry air as the pressure media. Media other than dry air may have adverse effects on sensor performance and long term reliability. Contact the factory for information regarding media compatibility in your application.

MPX10 MPXV10GC SERIES

PRESSURE (P1)/VACUUM (P2) SIDE IDENTIFICATION TABLE

Motorola designates the two sides of the pressure sensor as the Pressure (P1) side and the Vacuum (P2) side. The Pressure (P1) side is the side containing silicone gel which isolates the die from the environment. The Motorola pres-

sure sensor is designed to operate with positive differential pressure applied, $P1 > P2$.

The Pressure (P1) side may be identified by using the table below:

Part Number	Case Type	Pressure (P1) Side Identifier
MPX10D	344	Stainless Steel Cap
MPX10DP	344C	Side with Part Marking
MPX10GP	344B	Side with Port Attached
MPX10GS	344E	Side with Port Attached
MPXV10GC6U	482A	Side with Part Marking
MPXV10GC7U	482C	Side with Part Marking

ORDERING INFORMATION — UNIBODY PACKAGE

MPX10 series pressure sensors are available in differential and gauge configurations. Devices are available in the basic element package or with pressure port fittings which provide printed circuit board mounting ease and barbed hose pressure connections.

Device Type	Options	Case Type	MPX Series	
			Order Number	Device Marking
Basic Element	Differential	Case 344	MPX10D	MPX10D
Ported Elements	Differential	Case 344C	MPX10DP	MPX10DP
	Gauge	Case 344B	MPX10GP	MPX10GP
	Gauge	Case 344E	MPX10GS	MPX10D

ORDERING INFORMATION — SMALL OUTLINE PACKAGE (MPXV10GC SERIES)

Device Type/Order No.	Packing Options	Case Type	Device Marking
MPXV10GC6U	Rails	Case 482A	MPXV10G
MPXV10GC6T1	Tape and Reel	Case 482A	MPXV10G
MPXV10GC7U	Rails	Case 482C	MPXV10G

UNIBODY PACKAGE DIMENSIONS

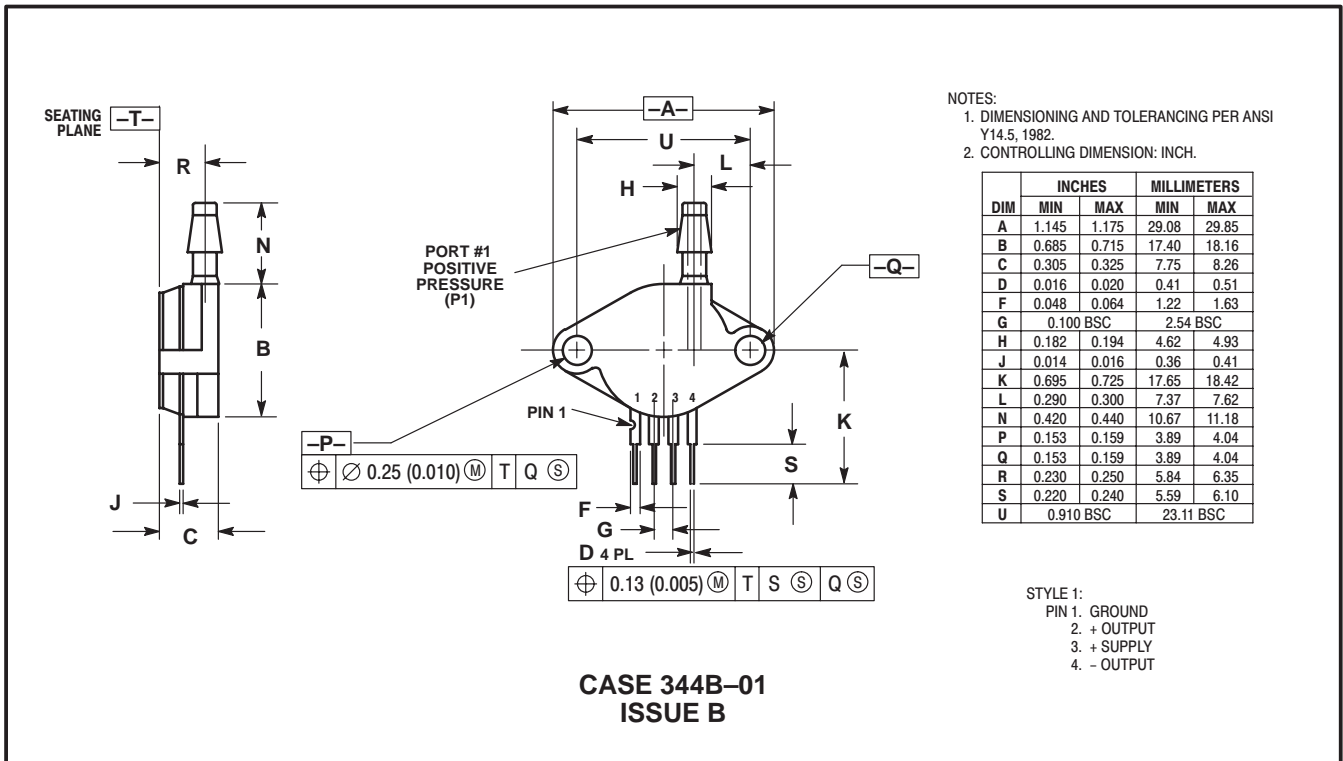
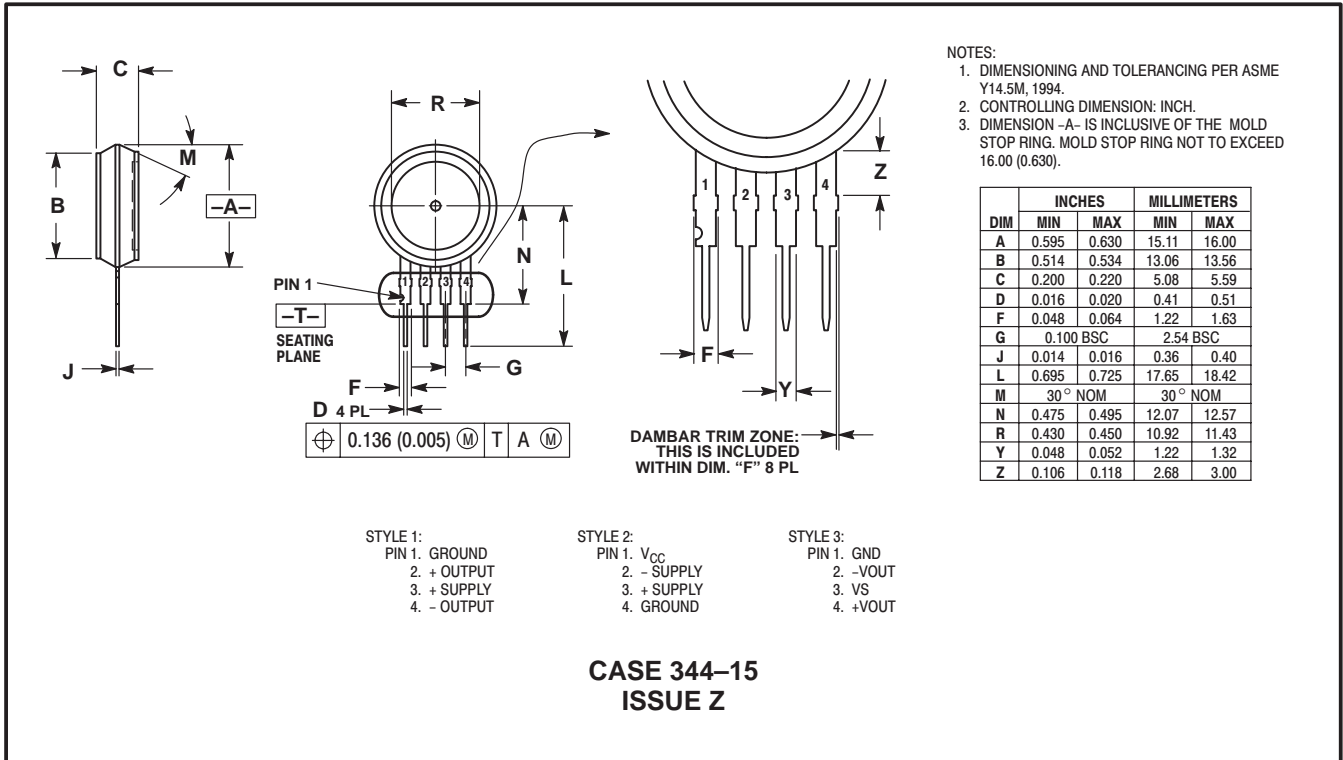

MPX10 MPXV10GC SERIES

UNIBODY PACKAGE DIMENSIONS — CONTINUED

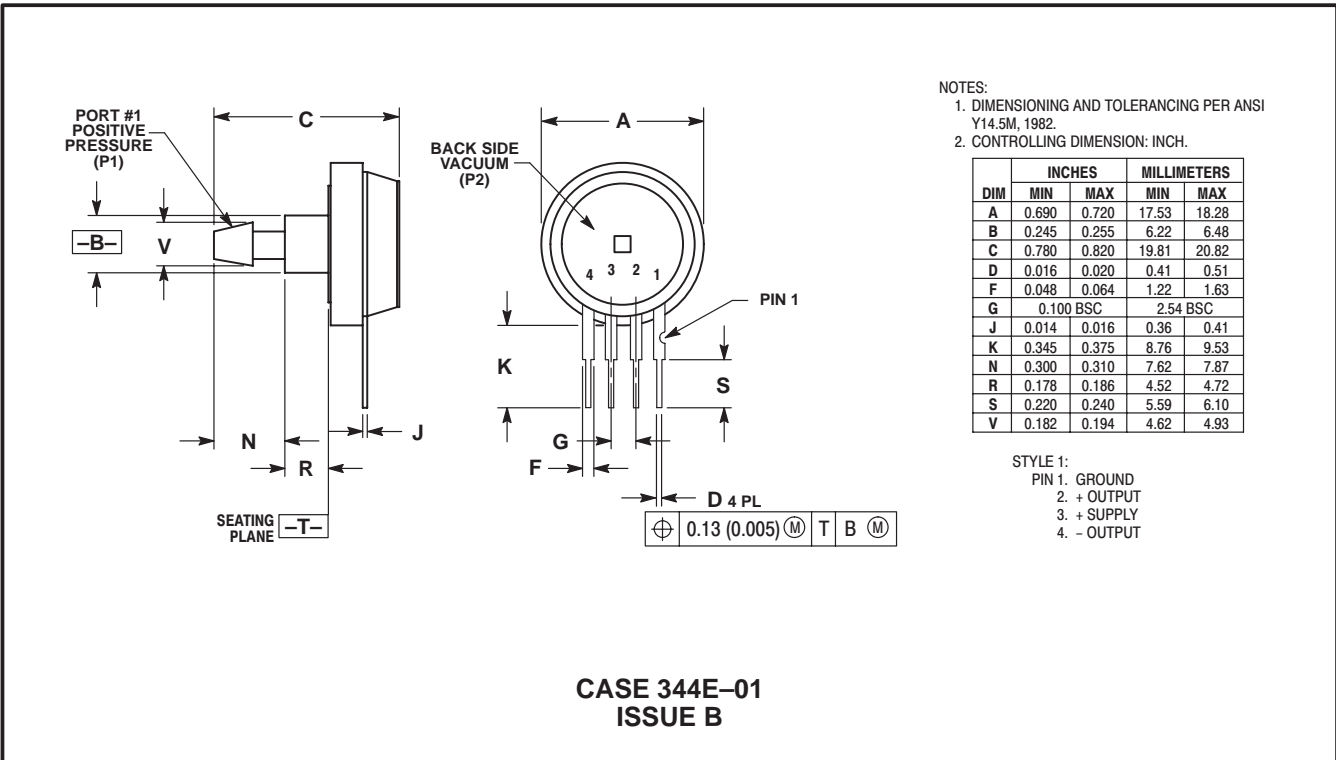
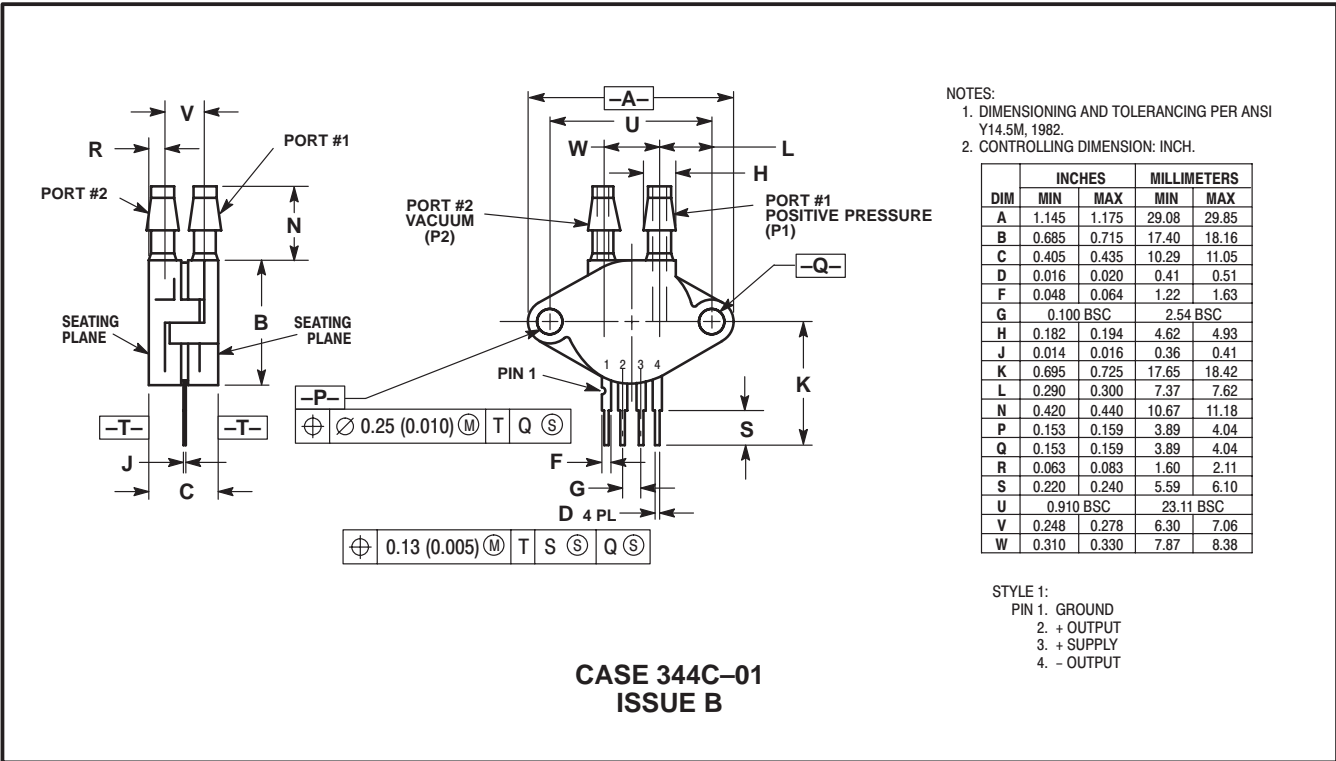

SMALL OUTLINE PACKAGE DIMENSIONS

