

PS/2 Touchpad Module	
PN: JME-T5012C, Rev.B	Page 1 of 10



PRODUCT SPECIFICATIONS

Sunrex Touchpad Module
53.50mm x 39.80 mm x 1.00mm(L x W x H)
P/N: JME-T5012C, Rev. B

REVISION HISTORY

Rev	Description	Release Date	Originator
A	New Product and Document	19/06/2007	Keymon Tsai
B	New Product and Document	07/07/2008	Keymon Tsai

The information contained in this document is proprietary. Except as specifically authorized, the holder of this document shall treat all information herein as confidential, and shall protect same in whole or part from disclosure and dissemination to third parties. Any proprietary information shall not be duplicated without the expressed written permission of Sunrex.

SUNREX TOUCHPAD MODULE

P/N: JME-T5012C

PRODUCT DESCRIPTION

The JME-T5012C is a high-performance Sunrex touchpad designed for notebooks and keyboards.

The Sunrex touchpad is an input device that will detect finger positions using a two-dimensional matrix of capacitive sensors on a 2-layer PCB board. Upon finger contact, the touchpad will report the finger's position (X/Y).

The touchpad construction consists of a matrixed sensing surface on one side and circuit components on the other side. The sensor side is electrically protected by a thin durable Plastic layer.

The Sunrex touchpad is compatible with standard Microsoft mouse drivers and is designed to communicate with the host using the PS/2 interface

The Sunrex touchpad uses patented technology for gesture detection and environmental noise suppression.

PRODUCT SPECIFICATIONS

- Accurate movement
- Low-effort activation
- Thin profile
- Solid-state, no moving components
- Low power consumption
- Small size
- Updateable control firmware
- Supports many gestures including:
 - Single-Click – emulates a single mouse “click”
 - Double-Click – emulates a mouse “double-click”
 - Click-and-Drag
- X/Y Cursor Navigation
- Accelerated Cursor Navigation
- Vertical Scrolling (as required)
- Horizontal Scrolling (as required)

ENVIRONMENTAL SPECIFICATIONS

Operating Temperature	0°C - 50°C
Operating Humidity	0% - 65% relative humidity, non-condensing
Storage Temperature	-20°C - 65°C

ELECTRICAL SPECIFICATIONS

Power Supply Voltage	5.0V \pm 10%
Power Supply Current	4.0 mA operating (nominal)
ESD	Air Discharge: \pm 8KV contact Discharge: \pm 4KV

ROHS COMPLIANCE

The Sunrex touchpad is a “green” product and is manufactured in compliance with the ROHS specifications. For further details, please contact your Sunrex Sales Representative for additional literature.

OPERATING SPECIFICATIONS

Touchpad Resolution	400 dpi (dots per inch)
Interface	PS/2® (Compatible with standard Microsoft® mouse driver)

PHYSICAL SPECIFICATIONS

Thickness	1.00 \pm 0.15mm PCB thickness 3.00mm overall thickness (with components)
Width	53.50 \pm 0.2mm
Bezel Opening	49.82 mm max (centered on the touchpad)
Height	39.80 \pm 0.2mm
Bezel Opening	36.17 mm max (centered on the touchpad)
Weight	g (including components)

COLOR SPECIFICATIONS

The Sunrex touchpad is available in a variety of colors. Please contact your Sunrex sales representative for details on the color scheme to best match your industrial design.

PHYSICAL DIMENSIONS

Figure 1: Sensor (Top) View

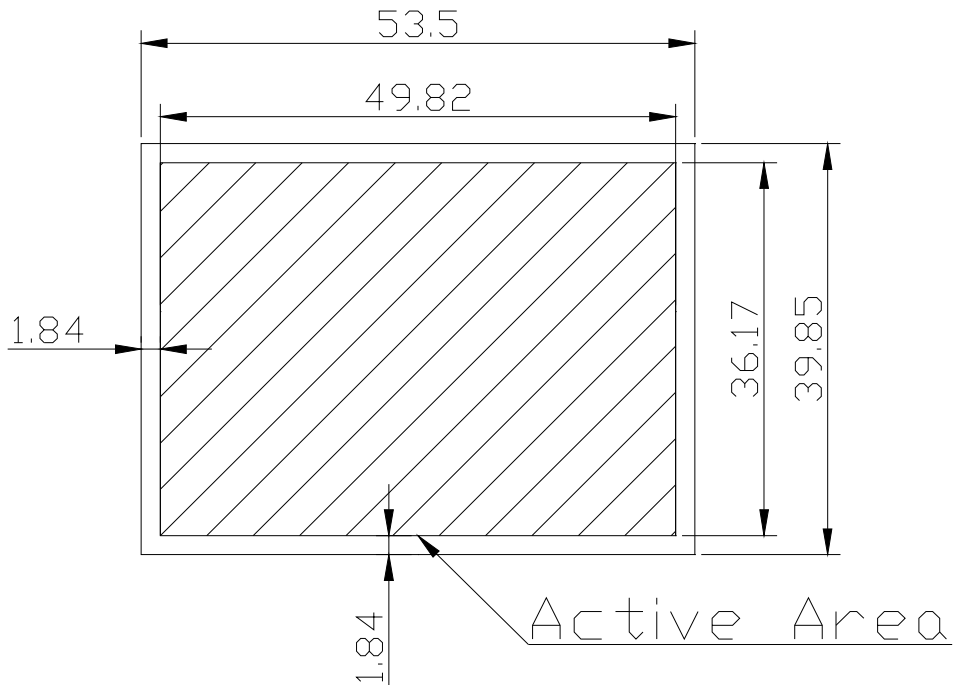
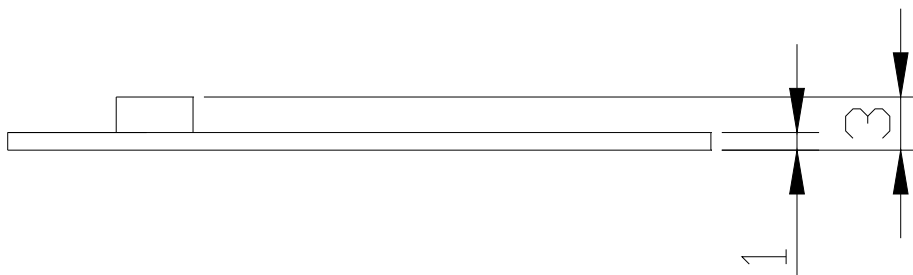
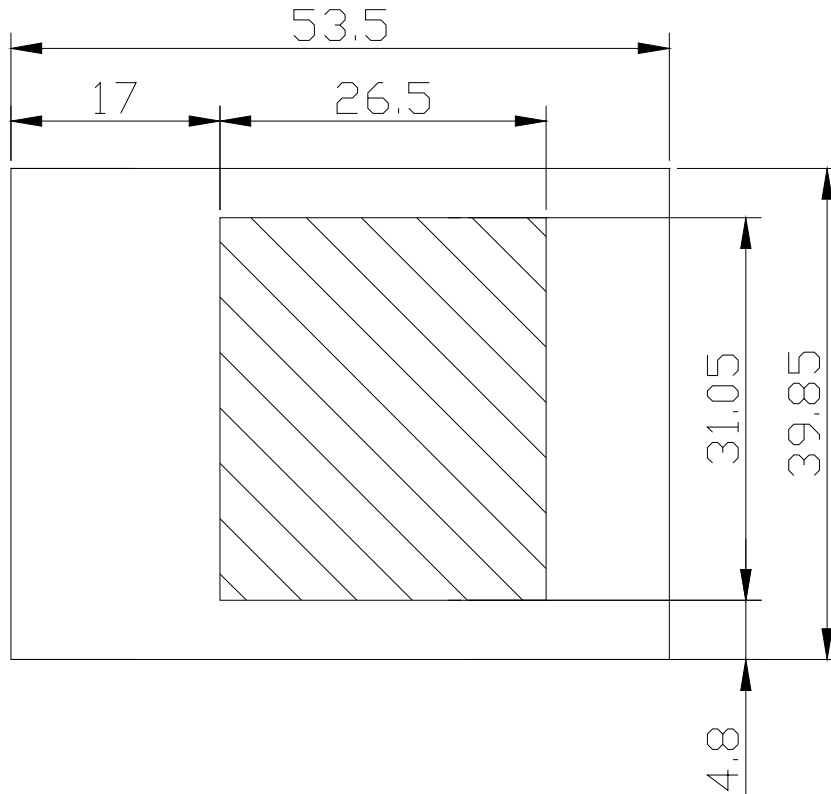

Figure 2: Side View



The information contained in this document is proprietary. Except as specifically authorized, the holder of this document shall treat all information herein as confidential, and shall protect same in whole or part from disclosure and dissemination to third parties. Any proprietary information shall not be duplicated without the expressed written permission of Sunrex.

Figure 3: Component (Bottom) View

Note: All dimensions above are in millimeters (mm).

In order to offer the best value to our end customers, Sunrex reserves the right to select the highest performance, lowest cost components from Sunrex' approved vendor list. Sunrex will guarantee that the final product will conform to the height, width and length provided in the specifications given above.

CONNECTOR SPECIFICATION

Figure 4: Module Connector

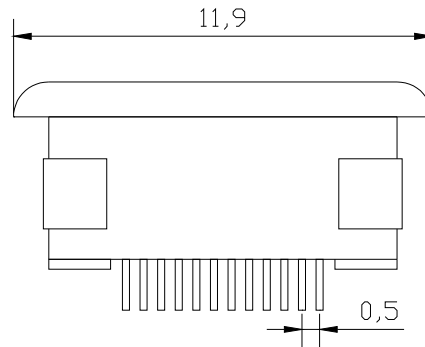
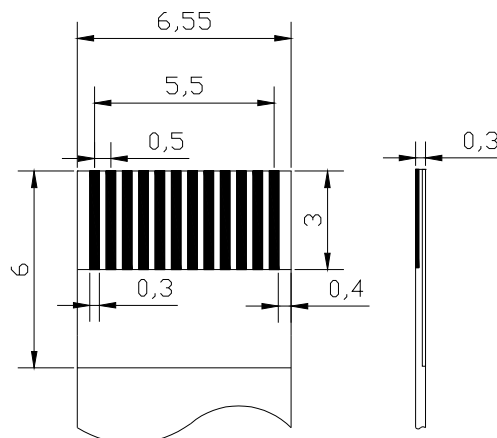

Figure 5: FFC Cable – 12-pin, 0.5 mm pitch cable



Pinout for 12-Pin Connector

Pin Number	Assignment	Description
1	RIGHT	Right Button Switch
2	RSVD	Reserved Input (No Connection)
3	RSVD	Reserved Input (No Connection)
4	LEFT	Left Button Switch
5	GND	Ground
6	GND	Ground
7	DATA	PS/2 Data
8	DATA	PS/2 Data
9	CLK	PS/2 Clock
10	CLK	PS/2 Clock
11	VDD	Power Supply Voltage
12	VDD	Power Supply Voltage

Note: All dimensions above are in millimeters (mm).

The information contained in this document is proprietary. Except as specifically authorized, the holder of this document shall treat all information herein as confidential, and shall protect same in whole or part from disclosure and dissemination to third parties. Any proprietary information shall not be duplicated without the expressed written permission of Sunrex.

MOUNTING ORIENTATION

Figure 6: TOP View

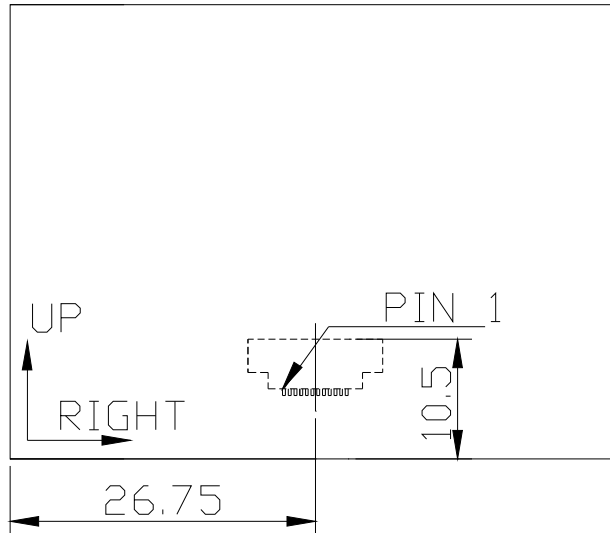

Note: Arrow indicates direction of finger movement.

INTERFACE INFORMATION

Figure 7: Touchpad/Host Connection (PS/2)

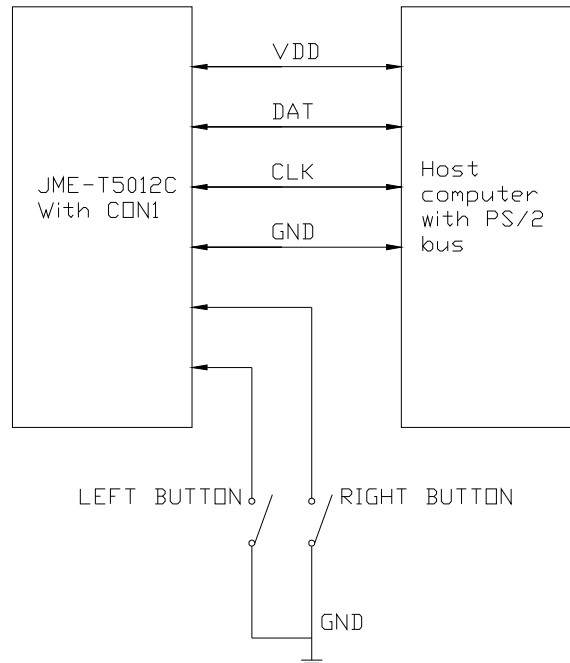

The information contained in this document is proprietary. Except as specifically authorized, the holder of this document shall treat all information herein as confidential, and shall protect same in whole or part from disclosure and dissemination to third parties. Any proprietary information shall not be duplicated without the expressed written permission of Sunrex.

MOUNTING CONSIDERATIONS

BUTTON SHAPE AND PLACEMENT

Sunrex touchpads already contains hardware and firmware hooks to support left and right mechanical click buttons. There are no restrictions in its shape or placement. However, generally, thin and wide buttons placed next to each other below the touchpad surface is a good configuration.

BEZEL PLACEMENT AND ALIGNMENT

The placement of the bezel is key to enable smooth touchpad operation. In general, the presence of a raised edge between the touchpad and the bezel gives tactile feedback to the user in “no-look” operation. When a user feels the raised edge between the touchpad and the bezel, he/she will know that the edge of the touchpad has been reached without ever having to look at the touchpad itself.

Sunrex recommends using a bezel that is at least 1.5 mm higher than the surface of the touchpad. It is also recommended that the bezel is either have rounded or steeply tapered edges. Do not use gradually tapered edges because it will encourage users to move beyond the active area of the touchpad during gesturing.

In order for the scrolling functions to operate correctly, it is essential to have the bezel centered on the touchpad.

TOUCHPAD MOUNTING

The Sunrex touchpad should be connected firmly to the system chassis below. This will prevent the touchpad from moving or shifting caused by high finger pressure on the touchpad surface.

Figure 3 indicates the bottom (component) side of the touchpad that is free from discrete components. This is where any supporting mount brackets should be attached. In addition, the brackets should be made of an insulating material so as not to disturb the sensing operation of the touchpad.

Metallic or other conductive brackets SHOULD ONLY make contact with the touchpad within the frame ground area as outlined in Figure 9 below. The frame ground should be firmly connected to system or chassis ground. Do not place conductive metal traces or objects near the traces or the components on the component side of the PCB board. As a good rule, any conductive object should be at least 1.5 mm away from any area of the touchpad.

ESD CONSIDERATIONS

In order to maximize electrostatic discharge protection, the touchpad must be shielded as much as possible. Although, the mylar surface provides good first-line defense against ESD, there are two additional ways to maximize ESD protection: provide a low impedance frame ground for the touchpad and provide a ground ring between the bezel and the touchpad.

PROVIDING A LOW IMPEDANCE FRAME GROUND TO TOUCHPAD

The information contained in this document is proprietary. Except as specifically authorized, the holder of this document shall treat all information herein as confidential, and shall protect same in whole or part from disclosure and dissemination to third parties. Any proprietary information shall not be duplicated without the expressed written permission of Sunrex.

A metallic frame should be made of a highly conductive material and should be in contact with all four areas of the frame ground on the touchpad. The metallic frame should then be connected to the system or chassis ground.

GROUND RING BETWEEN BEZEL AND TOUCHPAD

The underside of the bezel should be metalized and grounded. Additionally, all connections should be firmly connected to the system ground.

Figure 8: ESD Protection

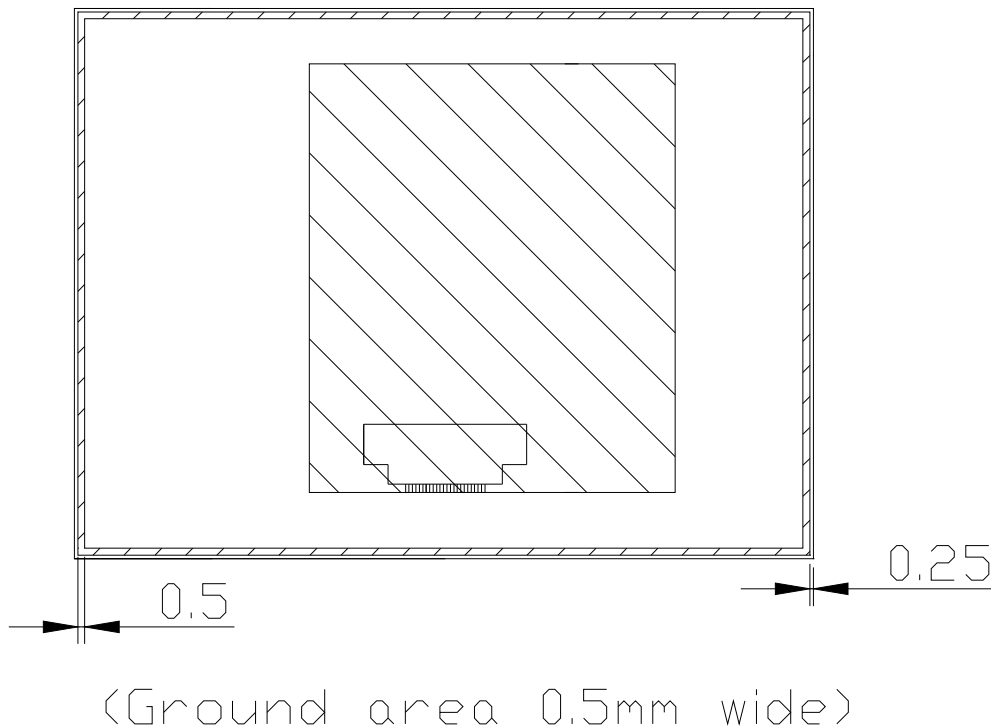

ORDERING INFORMATION

Please contact your local Sunrex sales representative for a complete list of Sunrex touchpad offerings.

Domestic:
Asia Pacific:
Fax:
Website:

The information contained in this document is proprietary. Except as specifically authorized, the holder of this document shall treat all information herein as confidential, and shall protect same in whole or part from disclosure and dissemination to third parties. Any proprietary information shall not be duplicated without the expressed written permission of Sunrex.