



PRODUCT SPECIFICATIONS

Sunrex Touchpad Module
58.6mm x 35.5 mm x 1.8mm(L x W x H)
P/N: JME-T5051A, Rev. 2.2

REVISION HISTORY

Rev	Description	Release Date	Originator
2.1	New Product and Document	6/17/2008	Keymon Tsai
2.2	correct Figure 6	07/07/2008	Keymon Tsai

SUNREX TOUCHPAD MODULE

P/N: JME-T5051A

PRODUCT DESCRIPTION

The JME-T5051A is a high-performance Sunrex touchpad designed for notebooks and keyboards.

The Sunrex touchpad is an input device that will detect finger positions using a two-dimensional matrix of capacitive sensors on a 2-layer PCB board. Upon finger contact, the touchpad will report the finger's position (X/Y).

The touchpad construction consists of a matrixed sensing surface on one side and circuit components on the other side. The sensor side is electrically protected by a thin durable Mylar layer. Although the Mylar layer is either colored black, or silver, they are available in a variety of colors and can be silk printed for customization.

The Sunrex touchpad is compatible with standard Microsoft mouse drivers and is designed to communicate with the host using the PS/2 interface

The Sunrex touchpad uses patented technology for gesture detection and environmental noise suppression.

PRODUCT SPECIFICATIONS

- Accurate movement
- Low-effort activation
- Thin profile
- Solid-state, no moving components
- Low power consumption
- Small size
- Updateable control firmware
- Supports many gestures including:
 - Single-Click – emulates a single mouse “click”
 - Double-Click – emulates a mouse “double-click”
 - Click-and-Drag
- X/Y Cursor Navigation
- Accelerated Cursor Navigation
- Vertical Scrolling (as required)
- Horizontal Scrolling (as required)

ENVIRONMENTAL SPECIFICATIONS

Operating Temperature	0°C - 50°C
Operating Humidity	0% - 65% relative humidity, non-condensing
Storage Temperature	-20°C - 65°C

ELECTRICAL SPECIFICATIONS

Power Supply Voltage	5.0V \pm 10%
Power Supply Current	4.0 mA operating (nominal)
ESD	not contact: \pm 8KV contact: \pm 4KV

ROHS COMPLIANCE

The Sunrex touchpad is a “green” product and is manufactured in compliance with the ROHS specifications. For further details, please contact your Sunrex Sales Representative for additional literature.

OPERATING SPECIFICATIONS

Touchpad Resolution	400 dpi (dots per inch)
Interface	PS/2® (Compatible with standard Microsoft® mouse driver)

PHYSICAL SPECIFICATIONS

Thickness	1.8mm PCB thickness (including Mylar) 3.8mm overall thickness (with components)
Width	58.6 \pm 0.20 mm
Bezel Opening	55.20mm max (centered on the touchpad)
Height	35.5 \pm 0.20mm
Bezel Opening	33.20mm max (centered on the touchpad)
Weight	7.7 \pm 1.0 g (including mylar and components)

COLOR SPECIFICATIONS

The Sunrex touchpad is available in a variety of colors. Please contact your Sunrex sales representative for details on the color scheme to best match your industrial design.

PHYSICAL DIMENSIONS

Figure 1: Sensor (Top) View

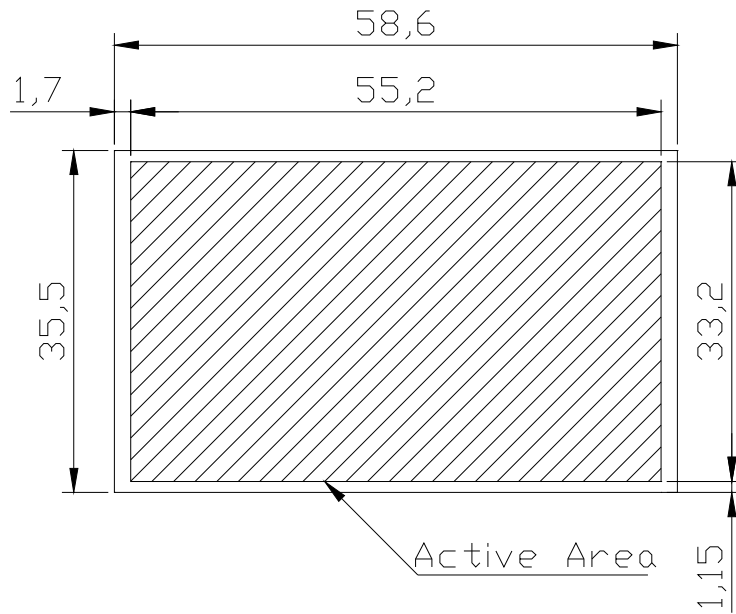

Figure 2: Side View

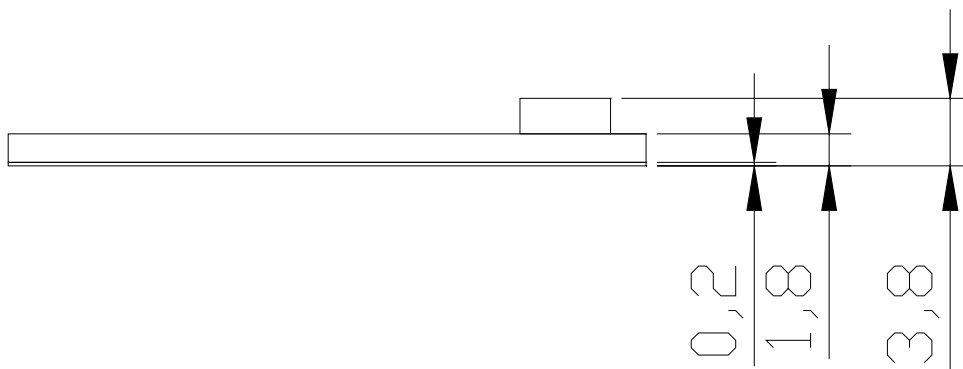
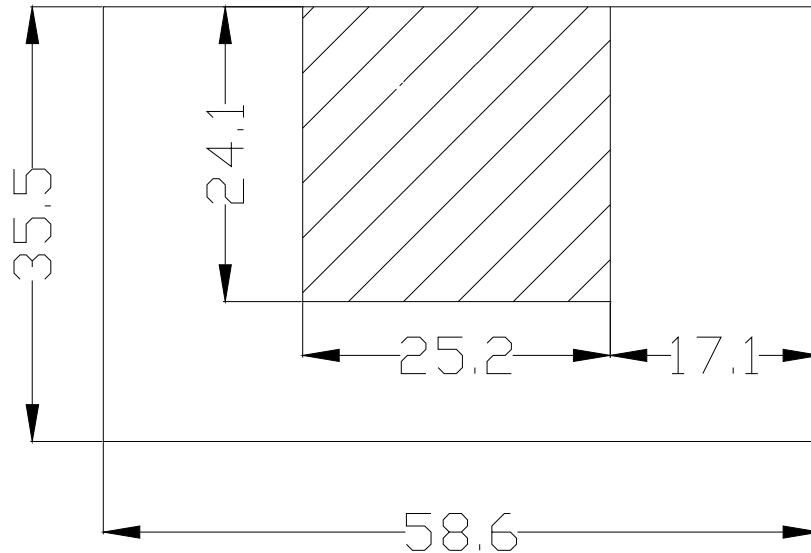

Figure 3: Component (TOP) View

Note: All dimensions above are in millimeters (mm).

In order to offer the best value to our end customers, Sunrex reserves the right to select the highest performance, lowest cost components from Sunrex' approved vendor list. Sunrex will guarantee that the final product will conform to the height, width and length provided in the specifications given above.

CONNECTOR SPECIFICATION

Figure 4: Module Connector

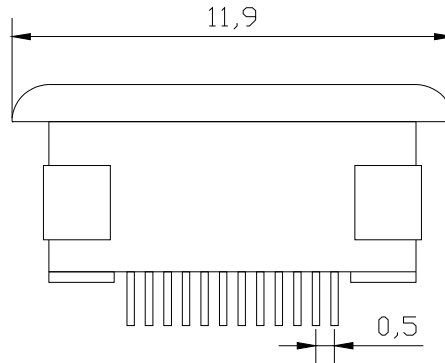
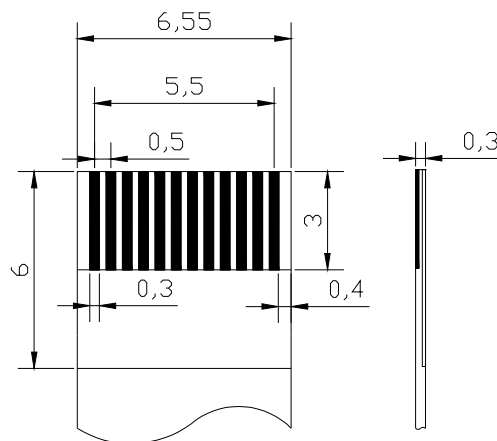

Figure 5: FFC Cable – 12-pin, 0.5 mm pitch cable



Pinout for 12-Pin Connector

Pin Number	Assignment	Description
12	RIGHT	Right Button
11	RIGHT	Right Button
10	LEFT	Left Button
9	LEFT	Left Button
8	VDD	+5V
7	VDD	+5V
6	DAT	PS/2 DATA
5	DAT	PS/2 DATA
4	CLK	PS/2 CLOCK
3	CLK	PS/2 CLOCK
2	GND	GND
1	GND	GND

Note: All dimensions above are in millimeters (mm).

The information contained in this document is proprietary. Except as specifically authorized, the holder of this document shall treat all information herein as confidential, and shall protect same in whole or part from disclosure and dissemination to third parties. Any proprietary information shall not be duplicated without the expressed written permission of Sunrex.

MOUNTING ORIENTATION

Figure 6: TOP View

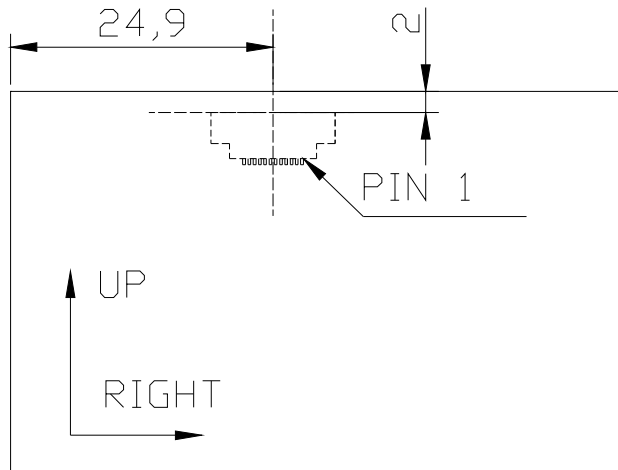

Note: Arrow indicates direction of finger movement.

INTERFACE INFORMATION

Figure 7: Touchpad/Host Connection (PS/2)

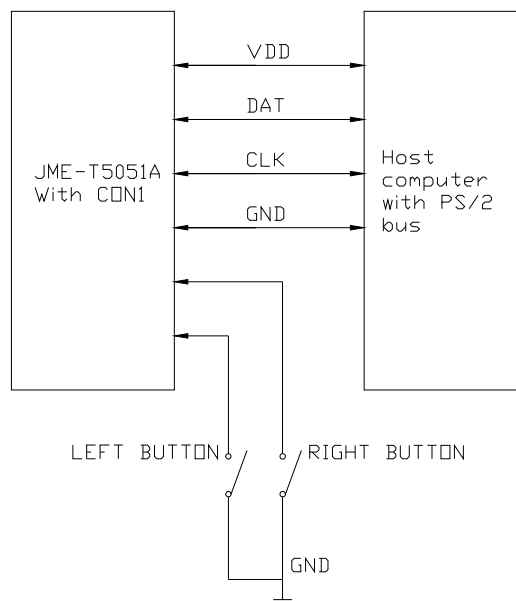

The information contained in this document is proprietary. Except as specifically authorized, the holder of this document shall treat all information herein as confidential, and shall protect same in whole or part from disclosure and dissemination to third parties. Any proprietary information shall not be duplicated without the expressed written permission of Sunrex.

MOUNTING CONSIDERATIONS

BUTTON SHAPE AND PLACEMENT

Sunrex touchpads already contains hardware and firmware hooks to support left and right mechanical click buttons. There are no restrictions in its shape or placement. However, generally, thin and wide buttons placed next to each other below the touchpad surface is a good configuration.

BEZEL PLACEMENT AND ALIGNMENT

The placement of the bezel is key to enable smooth touchpad operation. In general, the presence of a raised edge between the touchpad and the bezel gives tactile feedback to the user in “no-look” operation. When a user feels the raised edge between the touchpad and the bezel, he/she will know that the edge of the touchpad has been reached without ever having to look at the touchpad itself.

Sunrex recommends using a bezel that is at least 1.5 mm higher than the surface of the touchpad. It is also recommended that the bezel is either have rounded or steeply tapered edges. Do not use gradually tapered edges because it will encourage users to move beyond the active area of the touchpad during gesturing.

In order for the scrolling functions to operate correctly, it is essential to have the bezel centered on the touchpad.

TOUCHPAD MOUNTING

The Sunrex touchpad should be connected firmly to the system chassis below. This will prevent the touchpad from moving or shifting caused by high finger pressure on the touchpad surface.

Figure 3 indicates the bottom (component) side of the touchpad that is free from discrete components. This is where any supporting mount brackets should be attached. In addition, the brackets should be made of an insulating material so as not to disturb the sensing operation of the touchpad.

Metallic or other conductive brackets SHOULD ONLY make contact with the touchpad within the frame ground area as outlined in Figure 9 below. The frame ground should be firmly connected to system or chassis ground. Do not place conductive metal traces or objects near the traces or the components on the component side of the PCB board. As a good rule, any conductive object should be at least 1.5 mm away from any area of the touchpad.

ESD CONSIDERATIONS

In order to maximize electrostatic discharge protection, the touchpad must be shielded as much as possible. Although, the mylar surface provides good first-line defense against ESD, there are two additional ways to maximize ESD protection: provide a low impedance frame ground for the touchpad and provide a ground ring between the bezel and the touchpad.

PROVIDING A LOW IMPEDANCE FRAME GROUND TO TOUCHPAD

The information contained in this document is proprietary. Except as specifically authorized, the holder of this document shall treat all information herein as confidential, and shall protect same in whole or part from disclosure and dissemination to third parties. Any proprietary information shall not be duplicated without the expressed written permission of Sunrex.

A metallic frame should be made of a highly conductive material and should be in contact with all four areas of the frame ground on the touchpad. The metallic frame should then be connected to the system or chassis ground.

GROUND RING BETWEEN BEZEL AND TOUCHPAD

The underside of the bezel should be metalized and grounded. Additionally, all connections should be firmly connected to the system ground.

Figure 8: ESD Protection

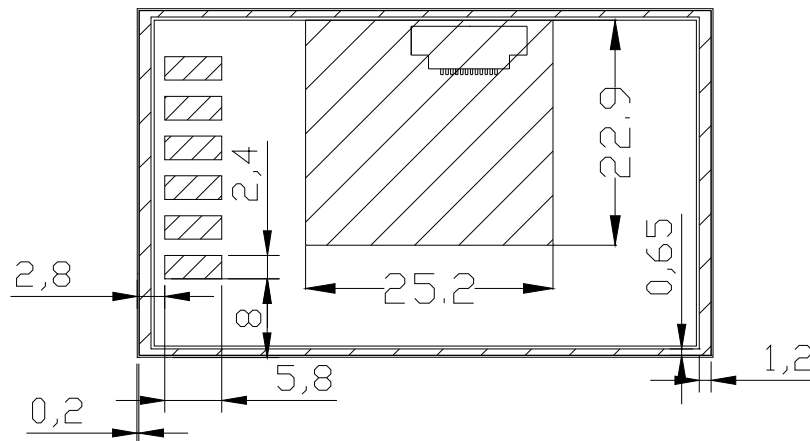

ORDERING INFORMATION

Please contact your local Sunrex sales representative for a complete list of Sunrex touchpad offerings.

Domestic:
Asia Pacific:
Fax:
Website: