

Back Connecting Sockets/Plate

Relay	Terminal	Model	
		Socket	Socket mounting plate
G2R-1-S□□ (1-pole)	Solder	P2R-05-A	P2R-P
	PC	P2R-05P	
G2R-2-S□□ (2-pole)	Solder	P2R-08A	
	PC	P2R-08P	

Specifications

■ Contact Data

Non-latching general purpose, plug-in, plug-in operation indicator self-contained, plug-in diode self-contained and upper-mount bracket.

Load	1-pole type		2-pole type	
	Resistive load (p.f. = 1)	Inductive load (p.f. = 0.4) (L/R = 7 ms)	Resistive load (p.f. = 1)	Inductive load (p.f. = 0.4) (L/R = 7 ms)
Rated load	10 A at 250 VAC 10 A at 30 VDC	7.5 A at 250 VAC 5 A at 30 VDC	5 A at 250 VAC 5 A at 30 VDC	2 A at 250 VAC 3 A at 30 VDC
Contact material	AgCdO			
Carry current	10 A		5 A	
Max. operating voltage	380 VAC, 125 VDC			
Max. operating current	10 A		5 A	
Max. switching capacity	2,500 VA, 300 W	1,875 VA, 150 W	1,250 VA, 150 W	500 VA, 90 W
Min permissible load	100 mA, 5 VDC		10 mA, 5 VDC	

Non-latching high capacity 1-pole type

Load	Resistive load (p.f. = 1)	Inductive load (p.f. = 0.4) (L/R = 7 ms)
Rated load	16 A at 250 VAC 16 A at 30 VDC	8 A at 250 VAC 8 A at 30 VDC
Contact material	AgCdO	
Carry current	16 A	
Max. operating voltage	380 VAC, 125 VDC	
Max. operating current	16 A	
Max. switching capacity	4,000 VA, 480 W	2,000 VA, 240 W
Min. permissible load	100 mA, 5 VDC	

Non-latching high-sensitivity

Load	1-pole type		2-pole type	
	Resistive load (p.f. = 1)	Inductive load (p.f. = 0.4) (L/R = 7 ms)	Resistive load (p.f. = 1)	Inductive load (p.f. = 0.4) (L/R = 7 ms)
Rated load	5 A at 250 VAC 5 A at 30 VDC	2 A at 250 VAC 3 A at 30 VDC	3 A at 250 VAC 3 A at 30 VDC	1 A at 250 VAC 1.50 A at 30 VDC
Contact material	AgCdO			
Carry current	5 A		3 A	
Max. operating voltage	380 VAC, 125 VDC			
Max. operating current	5 A		3 A	
Max. switching capacity	1,250 VA, 150 W	500 VA, 90 W	750 VA, 90 W	250 VA, 45 W
Min permissible load	100 mA, 5 VDC		10 mA, 5 VDC	

Socket

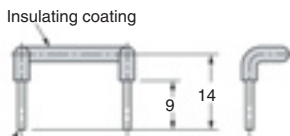

1.2 dia. conductor (See note 1.)

Note: 1. The relationship between the model, the length L, and the color of the insulating coating is shown in the following table.

Model	Length (L) mm	Color of insulating coating
P2RM-SR	14.3	Red
P2RM-SB		Blue

2. The insulating coating must be able to withstand a voltage of 3,000 V for 1 minute. Use either PE or PA as the material of the insulating coating.

3. The positions of the ends of the insulating coating must not vary more than 0.5 mm.

4. The characteristics of the socket bridge are shown in the following table.

Item	Characteristic
Rated ON current	10 A
Rated insulation voltage	250 VAC
Temperature rise	35°C max.
Dielectric strength	3,000 VAC for 1 minute
Ambient operating temperature	-55 to 70°C

Clip and Release Lever

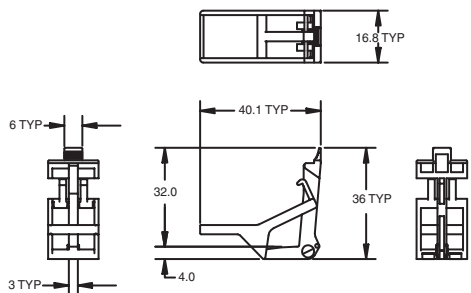

Back connecting socket

P2R-05P (1-pole) (UL E87929/CSA LR31928)

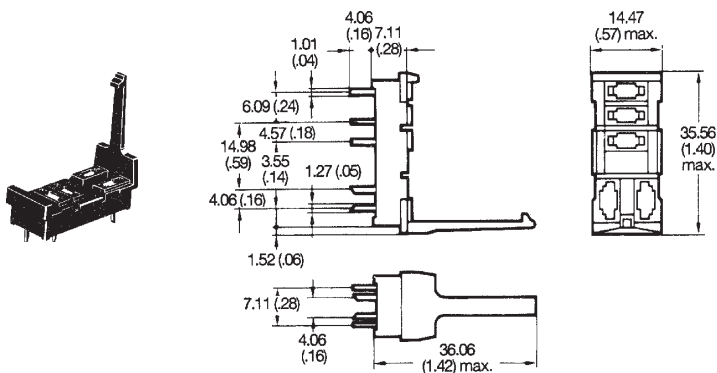

Terminal arrangement

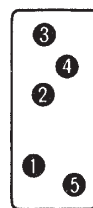

Mounting holes

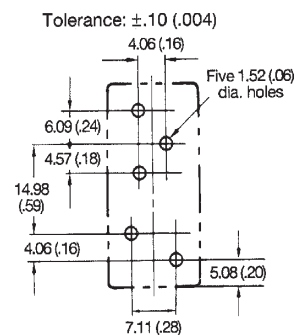

Note: 1. [Hatched box] and [Empty box] indicate mounting orientation marks.
2. A tolerance of ±0.10 (0.004) applies to the above dimensions.