

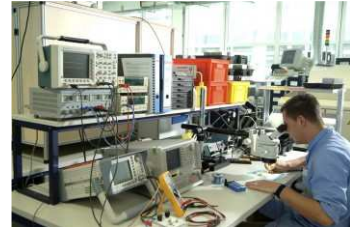

InnoSenT

Innovative Sensor Technology



NEW VERSION

Standard Products

Version: 2008-03-11

Inhaltsverzeichnis / table of contents

Ein paar kurze Worte über InnoSenT <i>/ about InnoSenT</i>	- 3 -
CW-Doppler-Radar für bewegte Objekte <i>/ CW doppler radar for moving objects</i>	- 5 -
CW/FMCW/FSK-Radar für bewegte und stationäre Objekte <i>/ CW/FMCW/FSK radar for moving and stationary objects</i>	- 11 -
Universelle Low-Cost Radar Transceiver <i>/ Universal Low-Cost radar transceivers</i>	- 17 -
Sonderprodukte <i>/ special products</i>	- 19 -
Appendix A: Antennendiagramme <i>/ antenna plots</i>	- 29 -
Sie haben Fragen zu unseren Produkten? <i>/ have you got further questions regarding our products?</i>	- 43 -

Ein paar kurze Worte über InnoSenT - about InnoSenT

Wer ist InnoSenT?

Die InnoSenT GmbH ist ein Komponentenhersteller und bietet seinen Kunden nicht nur Produkte, sondern Lösungen. InnoSenT entwickelt, produziert und vertreibt Radarsensoren im 24GHz-Bereich. Dabei beschränkt sich das angebotene Produktspektrum nicht nur auf das vorwiegend bekannte CW-Doppler Radar sondern auch auf FSK-, FMCW- und Pulsradare, mit denen neben der Geschwindigkeitsinformation auch noch die Entfernungsinformation gewonnen werden kann.



Werk Donnersdorf
Donnersdorf facility

Who is InnoSenT?

InnoSenT GmbH is a component manufacturer offering both products and solutions. InnoSenT develops, manufactures and distributes radar front ends in the 24GHz frequency band. The product range is not limited to pure doppler radars. We also offer FSK, FMCW and pulse radars that provide information about the speed and distance of an object.



Geschäftsführer Hr. Dr. Weidmann und Hr. Mock
managing directors Dr. W. Weidmann and R. Mock

Unsere Firmenphilosophie

Innovation – Qualität – Liefertreue

Innovation heißt, dass InnoSenT seine Radare anders baut als gewöhnlich
Qualität wird bereits „hineinentwickelt“ und durch unsere Prozess-
überwachung garantiert
Liefertreue weil wir hochzufriedene Kunden haben möchten!



Entwicklungsabteilung
development dept.

Our philosophy

Innovation – quality – on-time delivery

Innovation means, InnoSenT builds radars a bit different to others
Quality gets designed in, while our production processes are carefully
monitored
on-time delivery because we want to make our customers feel happy



Entwicklungsabteilung
- development dept.

Technologie und Verfahren

Die Designs von InnoSenT beruhen auf einer einheitlichen planaren Microstrip Technologie. Ultraflache Patchantennen erlauben die Realisierung eines vielfältigen Spektrums an Antennendiagrammen. State-of-the-Art Technologien für Oszillator und Mischer sind selbstverständlich

Technology and method

The designs from InnoSenT are based on a unique planar microstrip technology. Ultraslim patch antennas enable the realization of a various spectrums of antenna patterns. State-of-the-art technologies for oscillators and mixers are naturally used.

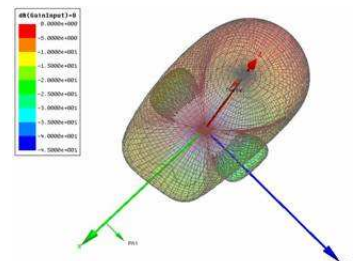

3D - Antennensimulation
3D – antenna simulation



Produktion
Production department

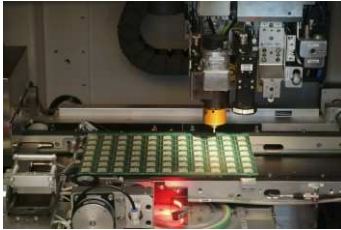

Präzisionsbestückung
board assembly



Messtechnik
measurement equipment

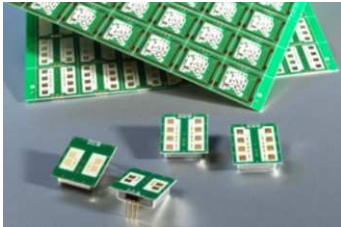

Low – Cost K-Band Transceiver IPM-165
Low – Cost K-Band Transceiver IPM-165

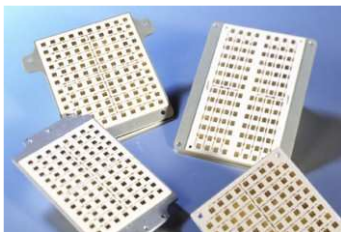

Produktbeispiel: Verkehrsmonitoring
example: traffic monitoring

Zertifikate

- DIN EN ISO 9001:2000 zertifiziert (Zert. Reg. Nr. 01 100 010350)
- Von Kunden auditiert gemäß VDA 6.3

Certifications

- *DIN EN ISO 9001:2000*
- *customer- audited according to VDA 6.3 (comparable with the QS 9000)*

Umweltschutz

- Umweltzertifizierung nach DIN EN ISO 14001 geplant für April 2008
- Alle InnoSenT Standardprodukte sind RoHs-konform

Environment protection



- DIN EN ISO 14001 scheduled for April 2008
- all InnoSenT standard products are compliant to the RoHs directive

Unser Produktspektrum

Auf den folgenden Seiten haben wir für Sie unser Standardproduktspektrum mit den wichtigsten Angaben zu dem jeweiligen Modul zusammengestellt.

Es stehen Module für folgende Radarverfahren zur Verfügung:

- CW-Doppler-Radar für bewegte Objekte
- FMCW/FSK für bewegte und stationäre Objekte zur Geschwindigkeits- u. Abstandsmessung
- Multi-Mode-Radars einschließlich Pulsbetrieb

Sollte keines der Module Ihren Anforderungen entsprechen, rufen Sie an (Kontaktinformationen auf der letzten Seite). Durch unsere hausinterne Entwicklungsabteilung und Produktion sind wir sicher, dass wir die passende Lösung für Ihr Problem finden werden.

Our products

The following pages list all of our standard products, together with the most important data.

We offer the following radar principles:

- CW doppler radar for moving objects
- FMCW / FSK radar for detection of moving and stationary objects including measurement of velocity, direction of motion, range and angle of arrival
- Multi-mode-radars including pulse-functionality

If you can't find what you are searching for, don't hesitate to contact us (contact information on the last page). With the help of our development department and our production department we are confident that we shall find the right solution to your problem.

CW-Doppler-Radar für bewegte Objekte

Die auch heute noch am meisten verwendeten Radarmodule beruhen auf dem CW-Doppler Prinzip. Über dieses Prinzip kann primär die Geschwindigkeit eines Objektes gemessen und dessen Bewegungsrichtung erkannt werden. Die Sensoren können aber auch als reine Präsenzmelder verwendet werden. Diese Messoptionen sind in vielen Bereichen von großer Bedeutung.

Typische Einsatzgebiete sind:

- Verkehrsleitsysteme / Verkehrsmonitoring
- Automatische Türöffner
- Alarmanlagen und Sicherheitstechnik
- Umweltmesstechnik
- Sportanwendungen

InnoSenT bietet hierfür eine Vielzahl von unterschiedlichen Radar-Modulen, mit denen diese Aufgaben erfüllt werden können.

Die Standardprodukte stellen wir auf den folgenden Seiten vor.

Sollten Ihre Anforderungen von den Produkten abweichen, können Sie auch gerne direkten Kontakt mit uns aufnehmen, wir sind sicher, dass wir auch für Ihr Problem eine passende Lösung finden.

CW doppler radar for moving objects

Most radar-modules today are utilizing the CW-Doppler principle. With these modules you can measure speed and the direction of movement of an object. The sensor can also be used for presence detection. These measurement options are very important in application areas like

- traffic monitoring
- automatic door openers
- alarm equipment
- sanitary equipment
- sport applications

InnoSenT GmbH offers a multitude of different radar modules for these application areas.

The standard products are listed on the following pages.

If your requirements are different, don't hesitate to contact us, we are sure that we shall find the right solution to your problem.

Überblick CW-Doppler-Radar für bewegte Objekte

Overview CW doppler radar for moving objects

model	mixers	amplifier		no. of antennas	antenna pattern [°]		side lobe suppr. [dB]	bandwidth limited	bandwidth	page
		IF	RF		horiz.	vert.				
IPS-144	Stereo	✓	✓	2	12	25	H = 20 V = 13	✓	50Hz...10kHz	6
IPS-146	Stereo	✓	✓	2	30	32	typ. 20	✓	50Hz...10kHz	7
IPS-154	Stereo	✓	x	2	45	38	typ. 13	✓	DC...50kHz	8
IPS-155	Stereo	✓	x	2	70	36	typ. 13	✓	DC...50kHz	9
IPS-168	Stereo	✓	✓	2	5	21	typ. 15	✓	50Hz...10kHz	10

Abbreviations:

IF = intermediate frequency
RF = radio frequency

K-Band Transceiver: IPS-144

Description:

- radar-based motion detector
- available in different frequency ranges: IPS-144, IPS-144_UK, IPS-144_F
- advanced PHEMT-oscillator with low current consumption
- RF-pre-amplifier for lowest noise operation
- split transmit and receive path for maximum gain
- stereo (dual channel) operation for direction of motion identification
- IF-pre-amplifier, bandwidth limited for lowest noise performance
- compact outline dimensions

Absolute Maximum Ratings:

Parameter	Symbol	Rating
supply voltage	V_{CC}	5.5 V
operating temperature (out of spec)	T_{OP}	- 40 °C / + 85 °C
storage temperature	T_{STG}	+ 90 °C

Interface:

The sensor provides a 2 mm pitch 6 pin connector Molex P/N 51004-0600.

Pin #	Description	In/Out	Comment
1	enable	input	active low
2	V_{CC}	input	supply voltage (+5 V)
3	GND	input	analog ground
4	IF2	output	Signal Q(uadrature)
5	IF1	output	Signal I(nphase)
6	not connected		

mates with: Molex P/N 53014, 53015 and 53025

Electrical Characteristics:

Parameter	Symbol	min.	typ.	max.	units	comment
transmit frequency	$f_{IPS-144}$	24.000	24.125	24.250	GHz	
	$f_{IPS-144_UK}$	24.150	24.200	24.250	GHz	
	$f_{IPS-144_F}$	24.075	24.125	24.175	GHz	
output power (EIRP)	P_{out}		20		dBm	
temperature drift	Δf		- 500		kHz/°C	
antenna pattern	horizontal		12		°	azimuth
	vertical		25		°	elevation
side lobe suppression	horizontal		20		dB	azimuth
	vertical		15		dB	elevation
I/Q balance	amplitude			6	dB	
	phase	60	90	120	°	
IF output	voltage offset		$V_{CC}/2$		V	
IF-amplifier	gain		50		dB	
	bandwidth		50 – 10k		Hz	
supply voltage	V_{CC}	4.75	5.0	5.25	V	
supply current	I_{CC}		60	80	mA	IF-amp included
operating temperature	T_{OP}	- 20		+ 60	°C	
outline dimensions		~ 65.8 x 65.8 x 11			mm	

Product Picture:

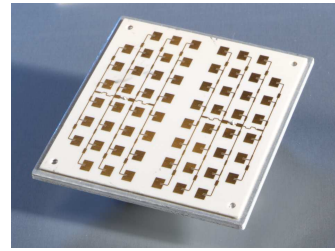

Mechanical Outlines: (dimensions in mm)

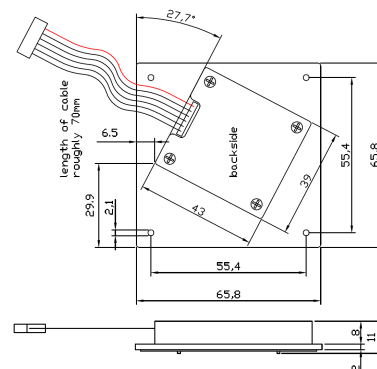

Pin Description / Antenna Planes

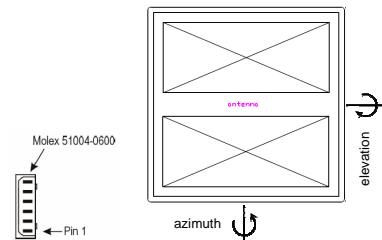

K-Band Transceiver: IPS-146

Description:

- radar-based motion detector
- available in different frequency ranges: IPS-146, IPS-146_UK, IPS-146_F
- advanced PHEMT-oscillator with low current consumption
- RF-pre-amplifier for lowest noise operation
- split transmit and receive path for maximum gain
- stereo (dual channel) operation for direction of motion identification
- IF-pre-amplifier, bandwidth limited for lowest noise performance
- enable input for oscillator shut down
- small outline dimensions

Absolute Maximum Ratings:

Parameter	Symbol	Rating
supply voltage	V_{CC}	5.5 V
operating temperature (out of spec)	T_{OP}	- 40 °C / + 85 °C
storage temperature	T_{STG}	+ 90 °C

Interface:

The sensor provides a 2.54 mm grid, pin header (square pin □ 0.635 mm).

Pin #	Description	In/Out	Comment
1	NC		not connected
2	enable	input	active low
3	V_{CC}	input	supply voltage (+5 V)
4	GND	input	analog ground
5	IF2	output	Signal Q(uadrature)
6	IF1	output	Signal I(nphase)

Product Picture:

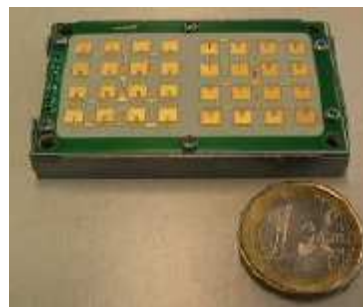

Mechanical Outlines:

(dimensions in mm)

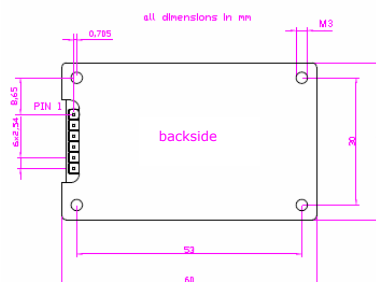
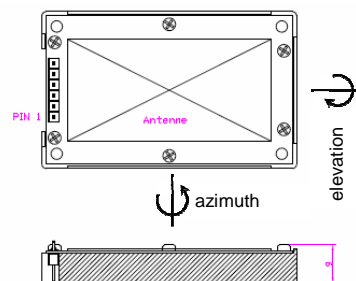

Electrical Characteristics:

Parameter	Symbol	min.	typ.	max.	units	comment
transmit frequency	$f_{IPS-146}$	24.000	24.125	24.250	GHz	
	$f_{IPS-146_UK}$	24.150	24.200	24.250	GHz	
	$f_{IPS-146_F}$	24.075	24.125	24.175	GHz	
output power (EIRP)	P_{out}		18		dBm	
temperature drift	Δf		- 1		MHz/°C	
antenna pattern	horizontal		30		°	azimuth
	vertical		32		°	elevation
side lobe suppression	horizontal		20		dB	azimuth
	vertical		20		dB	elevation
I/Q balance	amplitude			6	dB	
	phase	60	90	120	°	
IF output	voltage offset		$V_{CC}/2$		V	
IF-amplifier	gain		50		dB	
	bandwidth		50 – 10k		Hz	
supply voltage	V_{CC}	4.75	5.0	5.25	V	
supply current	I_{CC}		60	80	mA	IF-amp included
operating temperature	T_{OP}	- 20		+ 60	°C	
outline dimensions		~ 60 x 37 x 9			mm	

K-Band Transceiver: IPS-154

Description:

- radar-based motion detector
- available in different frequency ranges: IPS-154, IPS-154_UK, IPS-154_F
- advanced PHEMT-oscillator with low current consumption
- split transmit and receive path for maximum gain
- stereo (dual channel) operation for direction of motion identification
- IF-pre-amplifier, bandwidth limited for lowest noise performance
- economic flat-pack housing, extra small outline dimensions
- enable input for oscillator shut down

Absolute Maximum Ratings:

Parameter	Symbol	Rating
supply voltage	V _{CC}	5.5 V
operating temperature (out of spec)	T _{OP}	- 40 °C / + 85 °C
storage temperature	T _{STG}	+ 90 °C

Interface:

The sensor provides a 2.54 mm grid, pin header (square pin □ 0.635 mm).

Pin #	Description	In/Out	Comment
1	NC		not connected
2	enable	input	active low
3	V _{CC}	input	supply voltage (+5 V)
4	GND	input	analog ground
5	IF1	output	Signal I(n)phase)
6	IF2	output	Signal Q(uadrature)
7	NC		not connected
8	NC		not connected
9	GND	input	analog ground
10	NC		not connected

Electrical Characteristics:

Parameter	Symbol	min.	typ.	max.	units	comment
transmit frequency	f _{IPS-154}	24.000	24.125	24.250	GHz	
	f _{IPS-154_UK}	24.150	24.200	24.250	GHz	
	f _{IPS-154_F}	24.075	24.125	24.175	GHz	
output power (EIRP)	P _{out}		16		dBm	
temperature drift	Δf		- 1		MHz/°C	
antenna pattern	horizontal		45		°	azimuth
	vertical		38		°	elevation
side lobe suppression	horizontal		13		dB	azimuth
	vertical		13		dB	elevation
I/Q balance	amplitude			6	dB	
	phase	60	90	120	°	
IF output	voltage offset	1.0	2.2	4.0	V	
IF-amplifier	gain		20		dB	
	bandwidth		DC – 50k		Hz	
supply voltage	V _{CC}	4.75	5.0	5.25	V	
supply current	I _{CC}		35	50	mA	IF-amp included
operating temperature	T _{OP}	- 20		+ 60	°C	
outline dimensions		~ 44 x 30 x 8.3 (19)			mm	

Product Picture:

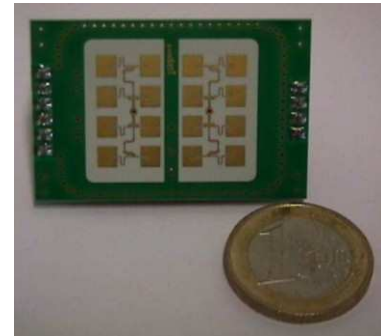

Mechanical Outlines: (dimensions in mm)

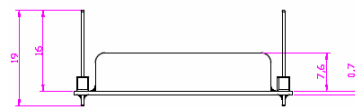
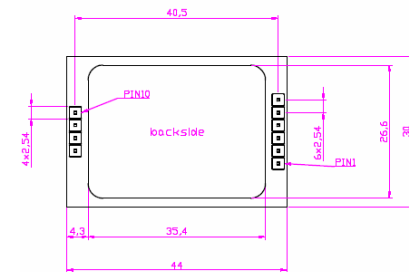

Pin Description / Antenna Planes:

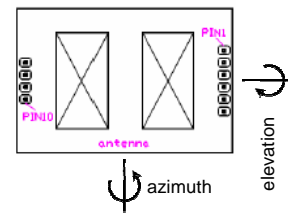

K-Band Transceiver: IPS-155

Description:

- radar-based motion detector
- available in different frequency ranges: IPS-155, IPS-155_UK, IPS-155_F
- advanced PHEMT-oscillator with low current consumption
- split transmit and receive path for maximum gain
- stereo (dual channel) operation for direction of motion identification
- IF-pre-amplifier, bandwidth limited for lowest noise performance
- economic flat-pack housing, extra small outline dimensions
- enable input for oscillator shut down

Absolute Maximum Ratings:

Parameter	Symbol	Rating
supply voltage	V_{CC}	5.5 V
operating temperature (out of spec)	T_{OP}	- 40 °C / + 85 °C
storage temperature	T_{STG}	+ 90 °C

Interface:

The sensor provides a 2.54 mm grid, single row pin header (square pin \square 0.635 mm).

Pin #	Description	In/Out	Comment
1	NC		not connected
2	enable	input	active low
3	V_{CC}	input	supply voltage (+5 V)
4	GND	input	analog ground
5	IF1	output	Signal I(nphase)
6	IF2	output	Signal Q(uadrature)
7	NC		not connected
8	NC		not connected
9	NC		not connected
10	NC		not connected

Electrical Characteristics:

Parameter	Symbol	min.	typ.	max.	units	comment
transmit frequency	$f_{IPS-155}$	24.000	24.125	24.250	GHz	
	$f_{IPS-155_UK}$	24.150	24.200	24.250	GHz	
	$f_{IPS-155_F}$	24.075	24.125	24.175	GHz	
output power (EIRP)	P_{out}		15		dBm	
temperature drift	Δf		- 1		MHz/°C	
antenna pattern	horizontal		70		°	azimuth
	vertical		36		°	elevation
side lobe suppression	horizontal		13		dB	azimuth
	vertical		13		dB	elevation
I/Q balance	amplitude			6	dB	
	phase	60	90	120	°	
IF output	voltage offset	1.0	2.2	4.0	V	
IF-amplifier	gain		20		dB	
	bandwidth		DC – 50k		Hz	
supply voltage	V_{CC}	4.75	5.0	5.25	V	
supply current	I_{CC}		35	50	mA	IF-amp included
operating temperature	T_{OP}	- 20		+ 60	°C	
outline dimensions		~ 44 x 30 x 8.3 (19)			mm	

Product Picture:

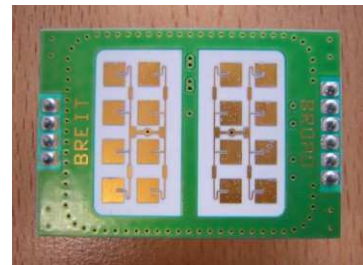

Mechanical Outlines: (dimensions in mm)

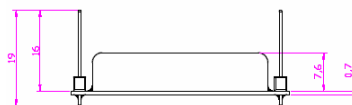
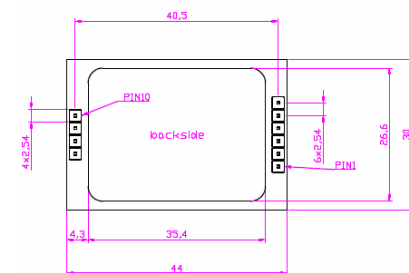

Pin Description / Antenna Planes:

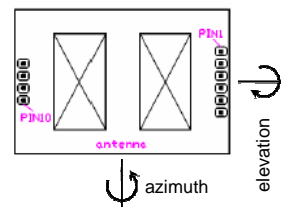

K-Band Transceiver: IPS-168

Description:

- radar-based motion detector centered @ 24.125 GHz
- advanced PHEMT-oscillator with low current consumption
- RF-pre-amplifier for lowest noise operation
- split transmit and receive path for maximum gain
- stereo (dual channel) operation for direction of motion identification
- IF-pre-amplifier, bandwidth limited for lowest noise performance
- enable input for oscillator shut down
- compact outline dimensions

Absolute Maximum Ratings:

Parameter	Symbol	Rating
supply voltage	V_{CC}	5.5 V
operating temperature (out of spec)	T_{OP}	- 40 °C / + 85 °C
storage temperature	T_{STG}	+ 90 °C

Interface:

The sensor provides a 2 mm pitch 6 pin connector Molex P/N 51004-0600.

Pin #	Description	In/Out	Comment
1	enable	input	active low
2	V_{CC}	input	supply voltage (+5 V)
3	GND	input	analog ground
4	IF2	output	Signal Q(uadrature)
5	IF1	output	Signal I(nphase)
6	not connected		

mates with: Molex P/N 53014, 53015 and 53025

Electrical Characteristics:

Parameter	Symbol	min.	typ.	max.	Units	Comment
transmit frequency	f	24.000	24.125	24.250	GHz	
output power (EIRP)	P_{out}		20		dBm	
temperature drift	Δf		- 500		kHz/°C	
antenna pattern	horizontal		5		°	azimuth
	vertical		22		°	elevation
side lobe suppression	horizontal		15		dB	azimuth
	vertical		15		dB	elevation
I/Q balance	amplitude			6	dB	
	phase	60	90	120	°	
IF output	voltage offset		$V_{CC}/2$		V	
IF-amplifier	gain		50		dB	
	bandwidth		50 – 10k		Hz	
supply voltage	V_{CC}	4.75	5.0	5.25	V	
supply current	I_{CC}		60	80	mA	
operating temperature	T_{OP}	-25		+60	°C	
outline dimensions		~ 163 x 103 x 11			mm	

Product Picture:



Mechanical Outlines:

(dimensions in mm)

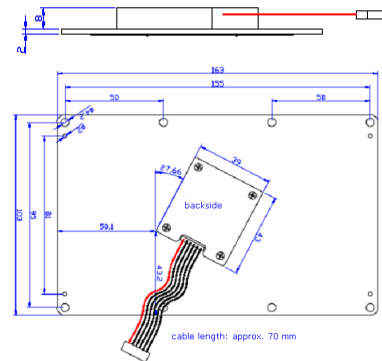

Pin Description / Antenna Planes:

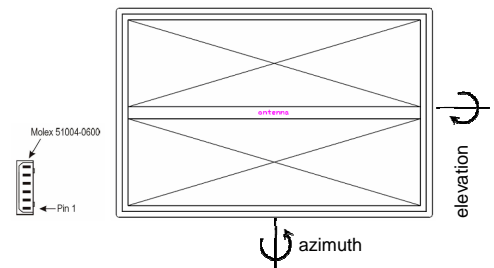

CW/FMCW/FSK-Radar für bewegte und stationäre Objekte

Durch die Verfügbarkeit preisgünstiger entsprechender Transceivermodule wird das FMCW-Radarprinzip im kommerziellen Bereich immer interessanter. In vielen Anwendungen soll der Sensor Informationen über stationäre Objekte oder bei bewegten Objekten zusätzliche Information zur reinen Bewegung, nämlich über deren Koordinaten im Raum liefern.

Das FMCW-Radarverfahren bietet diese Möglichkeiten und liefert

bei **bewegten Objekten** Information über

- augenblickliche Geschwindigkeit und Richtung der Bewegung (wie das übliche Dopplerradar)
- augenblickliche Entfernung des Objektes vom Sensor
- den Ablagewinkel des Objekts bei entsprechendem Aufbau

bei **stationären, also ruhenden Objekten** Information über

- Entfernung vom Sensor
- den Ablagewinkel des Objekts bei entsprechendem Aufbau

Bei entsprechender Auswertung der niederfrequenten Empfangssignale ist ein FMCW-Radar auch **mehrzielfähig**, d.h. es kann verschiedene Ziele hinsichtlich Geschwindigkeit und Entfernung und damit hinsichtlich der augenblicklichen Raumkoordinaten unterscheiden. Für alle diese Möglichkeiten bietet InnoSenT den passenden Sensor. Die Standardprodukte werden wir auf den folgenden Seiten vorstellen. Sollten Ihre Anforderungen von den Produkten abweichen, können Sie auch gerne direkten Kontakt mit uns aufnehmen, wir sind sicher, dass wir auch für Ihr Problem eine passende Lösung finden.

CW/FMCW/FSK radar for moving and stationary objects

In commercial applications the FMCW radar principle becomes more and more interesting, since transceiver modules are available at low cost. In many applications the sensor shall provide data about stationary objects or in case of moving objects additional information like speed and range.

The FMCW radar principle offers this possibility and is providing information

in the case of **moving objects**

- instantaneous velocity and direction of motion (like the usual doppler radar)
- instantaneous distance of the object from the sensor
- the angle of arrival of the object with a certain receiver arrangement

in the case of **stationary objects**

- the distance from the sensor
- the angle of the object with a certain receiver arrangement.

With proper processing of the low-frequency receive signals the FMCW is **multitarget-capable**, that means it can distinguish between different objects regarding velocity and range and regarding the instantaneous coordinates in space.

Überblick FMCW/FSK-Radar für bewegte und stationäre Objekte

Overview FMCW/FSK radar for moving and stationary objects

model	mixers	amplifier		no. of antennas	antenna pattern [°]		side lobe suppr. [dB]	bandwidth limited	bandwidth	page
		IF	RF		horiz.	vert.				
IVS-148	Stereo	✓	✓	2	12	25	typ. 15	✓	50...100kHz	12
IVS-162	Stereo	✓	x	2	45	38	typ. 13	✓	DC...50kHz	13
IVS-163	Stereo	✓	x	2	70	36	typ. 13	✓	DC...50kHz	14
IVS-167	Stereo	x	x	1	7	11	typ. 15	x	50Hz...25kHz	15
IVS-179	Stereo	✓	✓	2	7	28	typ. 15	✓	50Hz...25kHz	16

Abbreviations:

IF = intermediate frequency
RF = radio frequency

K-Band VCO-Transceiver: IVS-148

Description:

- K-Band VCO radar transceiver
- CW / FSK / FMCW modes
- advanced PHEMT-oscillator with low current consumption
- RF-pre-amplifier for lowest noise operation
- separate transmit and receive path for maximum sensitivity
- stereo (dual channel) operation for direction of motion identification
- IF-pre-amplifier, bandwidth limited for lowest noise performance

Absolute Maximum Ratings:

Parameter	Symbol	Rating
supply voltage	V_{CC}	5.5 V
operating temperature (out of spec)	T_{OP}	- 40 °C / + 85 °C
storage temperature	T_{STG}	+ 90 °C

Interface:

The sensor provides a 2 mm pitch 6 pin connector Molex P/N 51004-0600.

Pin #	Description	In/Out	Comment
1	enable	input	active low
2	V_{CC}	input	supply voltage (+ 5 V)
3	GND	input	analog ground
4	IF2	output	Signal Q(uadrature)
5	IF1	output	Signal I(nphase)
6	V_{tune}	input	varactor tuning voltage

mates with: Molex P/N 53014, 53015 and 53025

Electrical Characteristics:

Parameter	Symbol	min.	typ.	max.	units	comment
transmit frequency	f		24.000 – 24.250		GHz	depending on varactor tuning voltage
varactor tuning voltage	V_{tune}	0.5		10	V	
varactor input impedance			10 k		Ω	
modulation input				150	kHz	
tuning slope			50		MHz/V	
output power	P_{out}		20		dBm	
temperature drift	Δf		- 900		kHz/°C	
antenna pattern	horizontal		12		°	azimuth
	vertical		25		°	elevation
side lobe suppression	horizontal		15		dB	azimuth
	vertical		15		dB	elevation
I/Q balance	amplitude			6	dB	
	phase	60	90	120	°	
IF output	voltage offset		$V_{CC}/2$		V	
IF-amplifier	gain		30		dB	
	bandwidth		50 – 100k		Hz	
supply voltage	V_{CC}	4.75	5.0	5.25	V	
supply current	I_{CC}		60	80	mA	
operating temperature	T_{OP}	- 20		+ 60	°C	
outline dimensions		~ 65.8 x 65.8 x 11			mm	compare drawing

Product Picture:

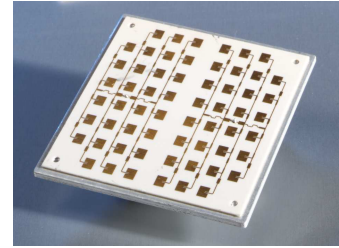

Mechanical Outlines: (dimensions in mm)

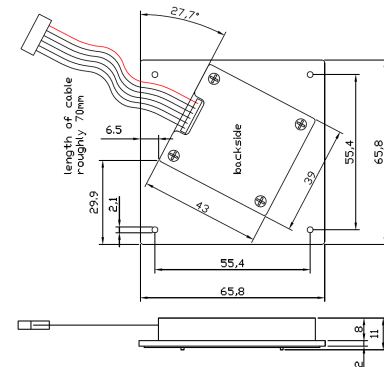

Pin Description / Antenna Planes

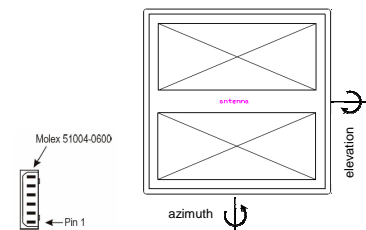

K-Band VCO-Transceiver: IVS-162

Description:

- K-Band VCO radar transceiver for FMCW/FSK applications
- advanced PHEMT-oscillator with low current consumption
- split transmit and receive path for maximum gain
- stereo (dual channel) operation for direction of motion identification
- IF-pre-amplifier, bandwidth limited for lowest noise performance
- economic flat-pack housing, extra small outline dimensions

Absolute Maximum Ratings:

Parameter	Symbol	Rating
supply voltage	V_{CC}	5.5 V
operating temperature (out of spec)	T_{OP}	- 40 °C / + 85 °C
storage temperature	T_{STG}	+ 90 °C

Interface:

The sensor provides a 2.54 mm grid, pin header (square pin \square 0.635 mm).

Pin #	Description	In/Out	Comment
1	V_{tune}	input	varactor tuning voltage
2	enable	input	active low
3	V_{CC}	input	supply voltage (+5 V)
4	GND	input	analog ground
5	IF1	output	Signal I(nphase)
6	IF2	output	Signal Q(uadrature)
7	NC		not connected
8	NC		not connected
9	GND	input	analog ground
10	GND	input	analog ground

Electrical Characteristics:

Parameter	Symbol	min.	typ.	max.	units	comment
transmit frequency	f		24.000 – 24.250		GHz	depending on varactor tuning voltage
varactor tuning voltage	V_{tune}	0.5		10	V	
varactor input impedance			1 k		Ω	
modulation input				150	kHz	
tuning slope		40			MHz/V	
output power	P_{out}		15		dBm	
temperature drift	Δf		- 1		MHz/°C	
antenna pattern	horizontal		45		°	azimuth
	vertical		38		°	elevation
side lobe suppression	horizontal		13		dB	azimuth
	vertical		13		dB	elevation
I/Q balance	amplitude			6	dB	
	phase	60	90	120	°	
IF output	voltage offset	1.0	2.2	4.0	V	
IF-amplifier	gain		20		dB	
	bandwidth		DC – 50k		Hz	
supply voltage	V_{CC}	4.75	5.0	5.25	V	
supply current	I_{CC}		35	50	mA	
operating temperature	T_{OP}	- 20		+ 60	°C	
outline dimensions		~ 44 x 30 x 8.3 (19)			mm	compare drawing

Product Picture:

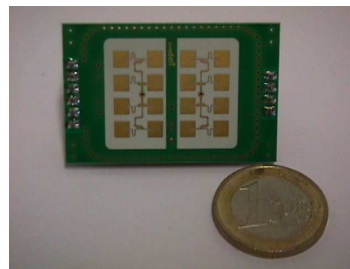

Mechanical Outlines:

(dimensions in mm)

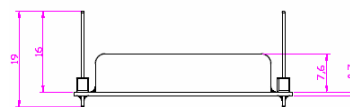
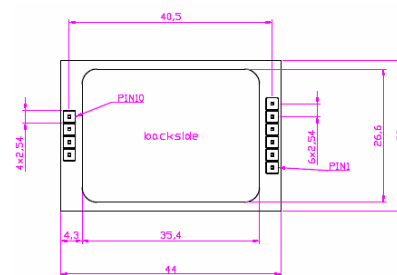

Pin Description / Antenna Planes:

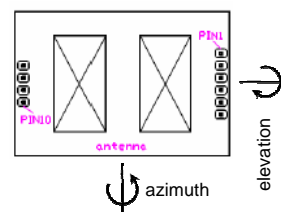

K-Band VCO-Transceiver: IVS-163

Description:

- K-Band VCO radar transceiver for FMCW/FSK applications
- advanced PHEMT-oscillator with low current consumption
- split transmit and receive path for maximum gain
- stereo (dual channel) operation for direction of motion identification
- IF-pre-amplifier, bandwidth limited for lowest noise performance
- economic flat-pack housing, extra small outline dimensions

Absolute Maximum Ratings:

Parameter	Symbol	Rating
supply voltage	V _{CC}	5.5 V
operating temperature (out of spec)	T _{OP}	- 40 °C / + 85 °C
storage temperature	T _{STG}	+ 90 °C

Interface:

The sensor provides a 2.54 mm grid, pin header (square pin □ 0.635 mm).

Pin #	Description	In/Out	Comment
1	V _{tune}	input	varactor tuning voltage
2	enable	input	active low
3	V _{CC}	input	supply voltage (+5 V)
4	GND	input	analog ground
5	IF1	output	Signal I(nphase)
6	IF2	output	Signal Q(uadrature)
7	NC		not connected
8	NC		not connected
9	NC		not connected
10	GND	input	analog ground

Electrical Characteristics:

Parameter	Symbol	min.	typ.	max.	units	comment
transmit frequency	f		24.000 – 24.250		GHz	depending on varactor tuning voltage
varactor tuning voltage	V _{tune}	0.5		10	V	
varactor input impedance			1 k		Ω	
modulation input				150	kHz	
tuning slope		40			MHz/V	
output power	P _{out}		15	20	dBm	
temperature drift	Δf		- 1		MHz/°C	
antenna pattern	horizontal		70		°	azimuth
	vertical		36		°	elevation
side lobe suppression	horizontal		13		dB	azimuth
	vertical		13		dB	elevation
I/Q balance	amplitude			6	dB	
	phase	60	90	120	°	
IF output	voltage offset	1.0	2.2	4.0	V	
IF-amplifier	gain		20		dB	
	bandwidth		DC – 50k		Hz	
supply voltage	V _{CC}	4.75	5.0	5.25	V	
supply current	I _{CC}		35	50	mA	
operating temperature	T _{OP}	- 20		+ 60	°C	
outline dimensions		~ 44 x 30 x 8.3 (19)			mm	compare drawing

Product Picture:

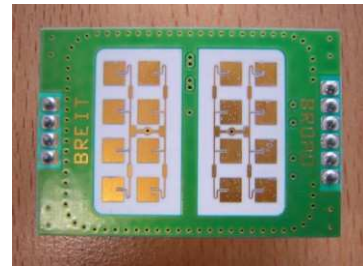

Mechanical Outlines:

(dimensions in mm)

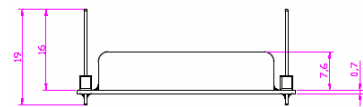
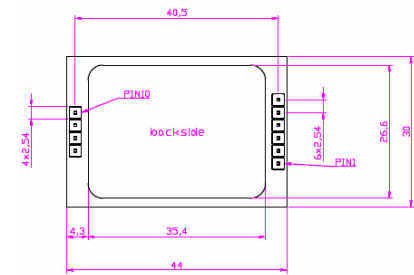

Pin Description / Antenna Planes:

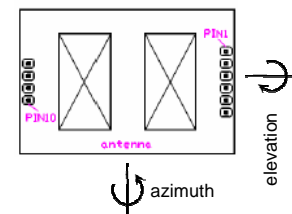

K-Band VCO-Transceiver: IVS-167

Description:

- K-Band VCO radar transceiver for FMCW/FSK applications
- advanced PHEMT-oscillator with low current consumption
- stereo (dual channel) operation
- integrated planar antenna

Environmental Tests and Handling Precautions:

- This InnoSenT sensor is sensitive to damage from ESD.
- Additional pre-cautions regarding ESD are required
- Applying multimeters e.g. for resistance measurement between any of the connector pins may cause damage to the module.



Absolute Maximum Ratings:

Parameter	Symbol	Rating
supply voltage	V_{CC}	5.5 V
operating temperature (out of spec)	T_{OP}	- 40 °C / + 85 °C
storage temperature	T_{STG}	+ 90 °C

Interface:

The sensor provides a 2.54 mm grid, single row pin header (square pin \square 0.635 mm).

Pin #	Description	In/Out	Comment
1	IF1	output	Signal I(nphase)
2	IF2	output	Signal Q(uadrature)
3	GND	input	analog ground
4	V_{CC}	input	supply voltage (+5 V)
5	V_{tune}	input	varactor tuning voltage

Electrical Characteristics:

Parameter	Symbol	min.	typ.	max.	units	comment
transmit frequency	f		24.000 – 24.250		GHz	depending on varactor tuning voltage
varactor tuning voltage	V_{tune}	0.5		8	V	
varactor input impedance			1 k		Ω	
modulation input				150	kHz	
tuning slope			50		MHz/V	
output power	P_{out}		18	20	dBm	
temperature drift	Δf		- 1		MHz/°C	
antenna pattern	horizontal		11		°	azimuth
	vertical		11		°	elevation
side lobe suppression	horizontal		15		dB	azimuth
	vertical		15		dB	elevation
I/Q balance	amplitude			6	dB	
	phase	60	90	120	°	
supply voltage	V_{CC}	4.75	5.0	5.25	V	
supply current	I_{CC}		33	40	mA	
operating temperature	T_{OP}	- 20		+ 60	°C	
outline dimensions		~ 75 x 75 x 11			mm	compare drawing

Product Picture:

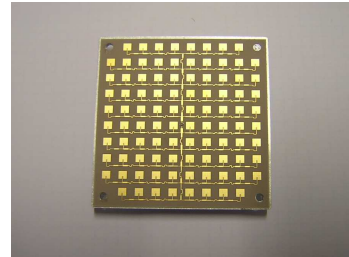

Mechanical Outlines: (dimensions in mm)

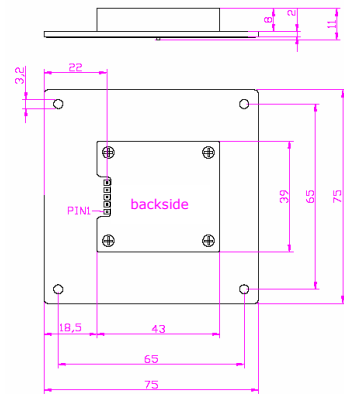

Antenna Pattern:

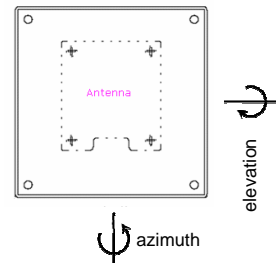

K-Band VCO-Transceiver: IVS-179

Description:

- K-Band VCO radar transceiver
- CW / FSK / FMCW modes
- advanced PHEMT-oscillator with low current consumption
- RF-pre-amplifier for lowest noise operation
- separate transmit and receive path for maximum sensitivity
- stereo (dual channel) operation for direction of motion identification
- IF-pre-amplifier

Absolute Maximum Ratings:

Parameter	Symbol	Rating
pos. supply voltage	V_{CC}	5.5V
neg. supply voltage	V_{SS}	-5.5V
operating temperature (out of spec)	T_{OP}	- 40 °C / + 85 °C
storage temperature	T_{STG}	+ 90 °C

Interface:

The sensor provides a 2 mm pitch 6 pin connector Molex P/N 51004-0600.

Pin #	Description	In/Out	Comment
1	V_{SS}	input	negative supply voltage (- 5 V)
2	V_{CC}	input	positive supply voltage (+ 5 V)
3	GND	input	analog ground
4	IF2	output	Signal Q(uadrature)
5	IF1	output	Signal I(nphase)
6	V_{tune}	input	varactor tuning voltage (0.5 V – 10 V)

mates with: Molex P/N 53014, 53015 and 53025

Electrical Characteristics:

Parameter	Symbol	min.	typ.	max.	units	comment
transmit frequency	f		24.000 – 24.250		GHz	depending on varactor tuning voltage
varactor tuning voltage	V_{tune}	0.5		10	V	
varactor input impedance			10 k		Ω	
modulation input				150	kHz	
tuning slope			50		MHz/V	
output power	P_{out}			20	dBm	
temperature drift	Δf		- 1		MHz/°C	
antenna pattern	horizontal		7		°	azimuth
	vertical		28		°	elevation
side lobe suppression	horizontal		15		dB	azimuth
	vertical		15		dB	elevation
I/Q balance	amplitude			6	dB	
	phase	60	90	120	°	
IF output	voltage offset		$V_{CC}/2$		V	
IF-amplifier	gain		33		dB	
	bandwidth		50 – 25k		Hz	
positive supply voltage	V_{CC}	4.75	5.0	5.25	V	
positive supply current	I_{CC}		60	80	mA	
negative supply voltage	V_{SS}	- 5.25	- 5.0	- 4.75	V	
negative supply current	I_{SS}		10	20	mA	
operating temperature	T_{OP}	- 20		+ 60	°C	
outline dimensions		~ 105 x 85 x 11			mm	compare drawing

Product Picture:

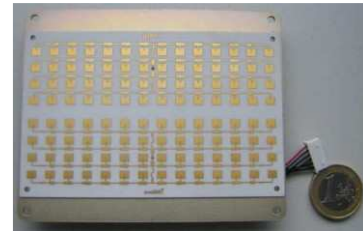

Mechanical Outlines: (dimensions in mm)

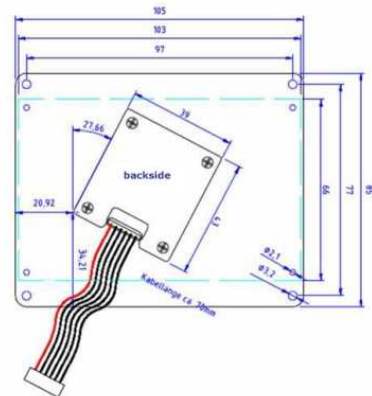

Pin Description / Antenna Planes:

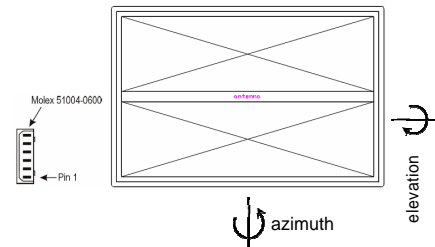

Universelle Low-Cost Radar Transceiver

Die bereits in vielen Anwendungen erfolgreiche Produktfamilie der Low-Cost Transceiver bietet Ihnen universell einsetzbare CW Radarmodule zu sehr attraktiven Preisen.

Die einzelnen Produkte zeichnen sich besonders durch Ihre kleinen Abmessungen und hohe Empfindlichkeit aus. Typische Einsatzgebiete für diese Module sind:

- Alarmanlagen und Sicherheitstechnik
- Haustechnik (z.B. Bewegungsmelder für automatische Lichtschalter)
- Automatische Türöffner

Die Standardprodukte stellen wir auf den folgenden Seiten vor:

Sollten Ihre Anforderungen von den Produkten abweichen, können Sie auch gerne direkten Kontakt mit uns aufnehmen, wir sind sicher, dass wir auch für Ihr Problem eine passende Lösung finden.

Universal Low-Cost radar transceivers

The highly appreciated product line of Low-Cost radar transceivers offers the possibility of universal applications at very attractive prices.

The specific products can be particularly characterized by their extra small outline dimensions and high sensitivity. The typical application areas of these modules include:

- Intrusion alarm and security
- Home automation (e.g. motion detector for automatic light switch)
- Automatic door openers

The standard products are listed on the following pages.

If your requirements are different, don't hesitate to contact us, we are sure that we shall find the right solution to your problem.

Überblick universelle Low-Cost Radar Transceiver

Overview universal Low-Cost radar transceivers

Low-Cost CW doppler radar for moving objects

<u>model</u>	<u>Mixers</u>	<u>no. of antennas</u>	<u>antenna pattern</u>		<u>side lobe suppression</u>	<u>supply voltage</u>	<u>page</u>
			horizontal	vertical			
IPM-165	Mono	2	80°	32°	typ. 13 dB	5 V	18
IPM-170	Mono	2	70°	70°	typ. 13 dB	5 V	18
IPM-365	Mono	2	80°	32°	typ. 13 dB	3 V	18
IPM-190	Mono	2	λ/4 dipole rod antennas			5 V	18

Environmental Tests and Handling Precautions:



- The InnoSenT universal Low-Cost radar transceivers are sensitive to damage from ESD.
- Additional pre-cautions regarding ESD are required
- Applying multimeters e.g. for resistance measurement between any of the connector pins may cause damage to the module.

Low-Cost CW doppler radar transceivers

K-Band Transceivers: IPM-165 / IPM-170 / IPM-190 / IPM-365

Description:

- radar-based motion detector
- available in different frequency ranges: Standard; _F and _UK variants
- advanced PHEMT-oscillator with low current consumption
- split transmit and receive path for maximum gain
- mono (single channel) operation for motion detection
- very small outline dimensions

Outline dimensions: (all dimensions in mm)

a) IPM-165/ IPM-170 / IPM-365:

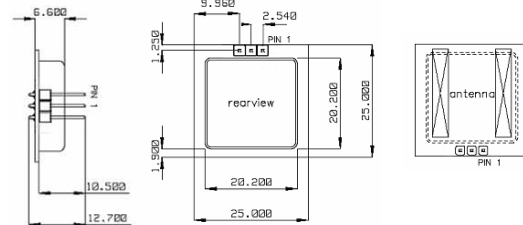

b) IPM-190:

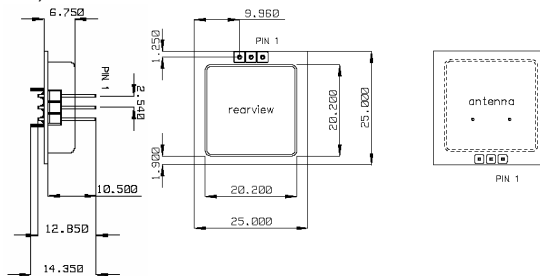

Absolute Maximum Ratings:

Parameter	Symbol	Rating
supply voltage IPM-165, IPM-170, IPM-190	V_{CC}	5.5 V
supply voltage IPM-365	V_{CC}	3.6 V
operating temperature (out of spec)	T_{OP}	- 40 °C / + 85 °C
storage temperature	T_{STG}	+ 90 °C

Interface:

The sensor provides a 2.54 mm grid, single row pin header (square pin \square 0.635 mm).

Pin #	Description	In/Out	Comment
1	V_{CC}	input	supply voltage
2	IF1	output	signal output
3	GND	input	analog ground

Pin Description / Antenna Planes

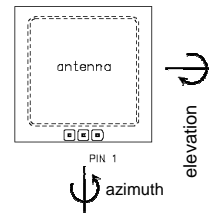

Common electrical characteristics:

Parameter	Symbol	min.	typ.	max.	Units	Comment
transmit frequency	$f_{Standard}$	24.000	24.125	24.250	GHz	
	$f_{UK_variant}$	24.150	24.200	24.250	GHz	
	$f_{F_variant}$	24.075	24.125	24.175	GHz	
temperature drift	Δf		- 1		MHz/°C	
IF output	voltage offset	-300		300	mV	
supply current	I_{CC}		30	40	mA	continuous operation
pulse length	t_{pulse}		10		μs	oscillator start time using V_{CC}
operating temperature	T_{OP}	-20		+60	°C	

Specific electrical characteristics:

Parameter	Symbol	IPM-165			IPM-170			IPM-365			IPM-190		
		min.	typ.	max.	min.	typ.	max.	min.	typ.	max.	min.	typ.	max.
output power (EIRP)	P_{out}		typ. 16 dBm		typ. 16 dBm		typ. 13 dBm		typ. 10 dBm				
antenna pattern	horizontal		typ. 80°		typ. 70°		typ. 80°		λ/4 dipole rod antennas				
	vertical		typ. 32°		typ. 70°		typ. 32°						
side lobe suppression	horizontal		typ. 13 dB		typ. 13 dB		typ. 13 dB						
	vertical		typ. 13 dB		typ. 13 dB		typ. 13 dB						
supply voltage	V_{CC} [V]	min. 4.75	typ. 5.0	max. 5.25	min. 4.75	typ. 5.0	max. 5.25	min. 2.85	typ. 3.0	max. 3.3	min. 4.75	typ. 5.0	max. 5.25
outline dimensions*	dim [mm]	~ 25 x 25 x 7 (12.7)			~ 25 x 25 x 7 (12.7)			~ 25 x 25 x 7 (12.7)			~ 25 x 25 x 7 (14.4)		

Cells marked in light green distinguish the respective sensor from the IPM-165.

* the numbers in brackets specify the size of the respective sensor including connector- and antenna pins. Compare drawing

Sonderprodukte - special products

Neben den bereits vorgestellten Standardmodulen bietet die InnoSenT GmbH noch weitere Produkte an, die weitergehende Anwendungen ermöglichen, Alternativen zu bestehenden Möglichkeiten zeigen und als kostbare Hilfsmittel in der Fertigung dienen können.

In addition to the already presented standard products, InnoSenT offers special products for advanced applications, alternatives to existing applications and products that are useful in production of radar equipment.

▪ **Radarschranke**

Die Radarschranke funktioniert nach dem ähnlichen Prinzip wie die bekannte Lichtschranke, ist aber wesentlich unanfälliger gegenüber Verschmutzung und anderen Umwelteinflüssen.

▪ **Dopplersimulator**

Der Dopplersimulator IDS-208 simuliert auf elektronischem Wege ein sich mit konstanter Geschwindigkeit in einer Richtung bewegendes Radarziel. Dies ermöglicht einem Anwender von CW-Dopplerradar-Sensoren, die am Ausgang anstehenden, niederfrequenten Empfangssignale bei

- einkanaligen Mono-Modulen hinsichtlich Amplitude und Frequenz (und damit Geschwindigkeit)
- zweikanaligen Stereo-Modulen (I/Q-Prinzip) hinsichtlich Amplitude, Frequenz (und damit Geschwindigkeit) jedes einzelnen Kanals und zusätzlich Phasenlage/Amplituden-Gleichheit der I/Q-Signale

zu vermessen. Damit erübrigen sich umständliche, räumlich ausgedehnte und mechanisch bewegte Aufbauten.

▪ **K-Band PLL Transceiver IVS-195**

Der PLL Radarsensor IVS-195 kann sowohl als klassisches CW-Doppler-Radar als auch als FMCW / FSK Radar eingesetzt werden. Der Sensor verfügt über einen Regelkreis zur Synchronisierung der Sendefrequenz. Dieser ermöglicht einen sehr stabilen Frequenzbereich und/oder eine sehr lineare Frequenzkurve.

▪ **K-Band Monopulse Transceiver IVQ-405**

Mit dem K-Band Monopulse Transceiver IVQ-405 ist neben den klassischen FMCW/FSK Anwendungen auch die Bestimmung des Ablagewinkels eines Objektes möglich.

▪ **Radar-Barrier**

The radar-barrier works on the same principle as a light barrier. The advantage of the radar barrier is its insensitivity against environmental influences

▪ **Doppler-Simulator**

Doppler simulator IDS-208 simulates an object moving with constant speed in one direction by electronic means. This enables the user of CW-Doppler sensors to evaluate and measure the low frequency output signals of

- single-channel mono modules regarding amplitude and frequency (and therefore velocity)
- dual-channel stereo modules (I/Q versions) regarding amplitude, frequency (and therefore velocity) of each individual channel and phase/amplitude balance of the I/Q signals.

Therefore bulky and complex mechanical constructions to simulate a moving object are no longer required.

▪ **K-Band PLL Transceiver IVS-195**

The K-Band PLL Transceiver can either be used as standard CW doppler radar or as FMCW / FSK radar. The sensors contains a feedback control system which synchronizes the transmit frequency. This enables a very stable frequency band and/or a very linear frequency ramp.

▪ **K-Band Monopulse Transceiver IVQ-405**

The K-Band Monopulse Transceiver IVQ-405 enables among the classic FMCW / FSK applications also the determination of the angle of arrival of an object.

K-Band Barrier: IPB-114

Description:

- same principle as light barrier
- insensitive against environmental influences
- consists out of two parts: transmitter IPT-114; receiver IPR-114
- transmitter and receiver centered @ 24.125 GHz
- advanced PHEMT-oscillator with low current consumption
- IF-pre-amplifier, bandwidth limited for lowest noise performance
- enable input for oscillator shut down and/or modulation
- economic flat-pack housing, extra small outlines dimensions

Absolute Maximum Ratings:

Parameter	Symbol	Rating
supply voltage	V _{CC}	5.5 V
operating temperature (out of spec)	T _{OP}	- 40 °C / + 85 °C
storage temperature	T _{STG}	+ 90 °C

Interface Transmitter (IPT-114):

The sensor provides a 2.54 mm grid, single row 6-pin header (square pin □ 0.635 mm) on the right side.

Pin #	Description	In/Out	Comment
1	enable	input	active low
2	GND	input	analog ground
3	V _{CC}	input	supply voltage (+5 V)
4	not connected		
5	not connected		
6	not connected		

Interface Receiver (IPR-114):

The sensor provides a 2.54 mm grid, single row 4-pin header (square pin □ 0.635 mm) on the left side.

Pin #	Description	In/Out	Comment
7	GND	input	analog ground
8	V _{CC}	input	supply voltage (+5 V)
9	IF1	output	Signal I(nphase)
10	IF2	output	Signal Q(uadrature)

Product Picture:

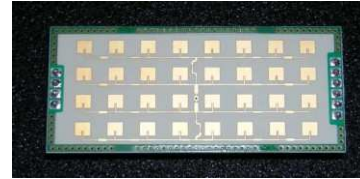

Mechanical Outlines: (dimensions in mm)

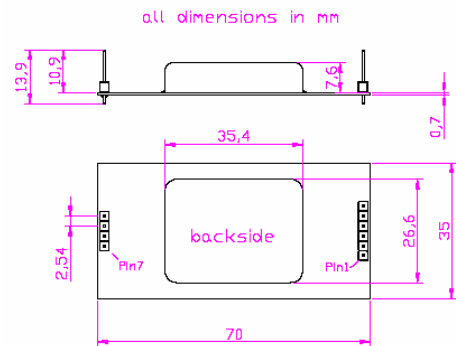

Pin Description:

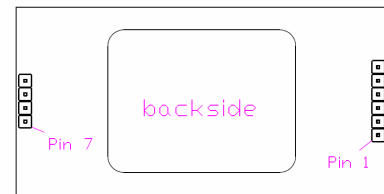

Antenna Planes:

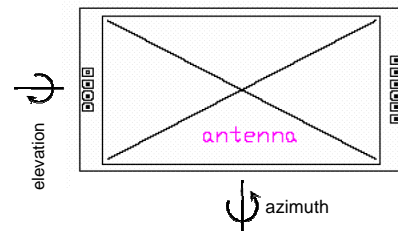

Electrical Characteristics

Parameter	Symbol	min.	typ.	max.	units	comment
Transmitter IPT-114						
transmit frequency	f_{transmit}	24.000	24.125	24.250	GHz	
output power (EIRP)	P_{out}		17	20	dBm	
temperature drift	Δf		- 1		MHz/°C	
antenna pattern	horizontal		31		°	azimuth
	vertical		15		°	elevation
side lobe suppression			18		dB	
modulation frequency	f_{mod}			10	kHz	
enable signal low	enable _{low}	0		2	V	
enable signal high	enable _{high}	3.5		V_{CC}	V	
supply voltage	V_{CC}	4.75	5.0	5.25	V	
supply current	I_{CC}		35	40	mA	
operating temperature	T_{OP}	- 40		+ 85	°C	
outline dimensions		~ 70 x 35 x 8.3 (13.9)			mm	compare drawing
Receiver IPR-114						
receive frequency	f_{receive}	24.000	24.125	24.250	GHz	
antenna pattern	horizontal		31		°	azimuth
	vertical		15		°	elevation
side lobe suppression			18		dB	azimuth
receiver sensitivity		- 42			dBm	
IF-output*	voltage offset			0.2	V	
IF-amplifier	gain		60		dB	
	bandwidth		20k		Hz	
supply voltage	V_{CC}	4.5	5.0	5.25	V	
supply current	I_{CC}		4	5	mA	
operating temperature	T_{OP}	- 40		+ 85	°C	
outline dimensions		~ 70 x 35 x 8.3 (13.9)			mm	compare drawing

* AM / pulse demodulator detection of AM modulated signals only. Modulation frequency: 100 Hz – 10 kHz.

Doppler-Simulator: IDS-208

Description:

- doppler / moving object simulation @ 24.125 GHz
- wide range of doppler frequencies available
- essential for test and development of CW-based doppler radars
- includes two parts (IDS-208 RF-simulator and ISG-207 driver-generator) plus connecting cable assembly
- instruction manual available on request

Product Picture:



Environmental Tests and Handling Precautions:

- CAUTION: Electronic Sensitive Devices. Use proper ESD handling procedures



Absolute Maximum Ratings:

Parameter	Symbol	Rating	Units
supply voltage RF-simulator (IDS-208)	V _{CC}	+ / - 6	V (DC)
supply voltage driver-generator (ISG-207)	V _{CC}	16	V (DC)
modulation voltage	V _{CC}	5	V (peak-peak)
operating temperature (out of spec)	T _{OP}	+ 70	°C
storage temperature	T _{STG}	+ 70	°C

Electrical Characteristics RF-Simulator IDS-208:

Parameter	Symbol	min.	typ.	Max.	units	comment
operational frequency	f	24.000	24.125	24.250	GHz	
antenna pattern	horizontal		11		°	azimuth
	vertical		21		°	elevation
side lobe suppression	horizontal		20		dB	azimuth
	vertical		20		dB	elevation
doppler frequency			0 – 100k		Hz	
modulation signal			+ 5		V	peak-peak (AC coupled)
supply voltage	V _{CC}		+ / - 5		V	
supply current	I _{CC}		135		mA	
operating temperature	T _{OP}	+ 15		+ 30	°C	
outline dimensions		~ 110 x 90 x 38			mm	

Interface RF-Simulator IDS-208

D-Sub-connector (female type)

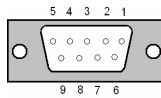

Pin #	Description	Comment
1	GND	
2	GND	
3	GND	
4	S2 in	
5	S1 in	
6	- 5V	
7	+ 5V	OP
8	N.C.	
9	+ 5V	MMIC1

Electrical Characteristics Driver-Generator ISG-207:

Parameter	Symbol	min.	typ.	Max.	units
supply voltage	V_{CC}	14		16	V
supply current	I_{CC}		90		mA
operating temperature	T_{OP}	0		+ 60	°C
outline dimensions					mm

Interface Driver-Generator ISG-207 to RF-Simulator IDS-208

For connection of ISG-207 to IDS-208 use attached cable assembly.

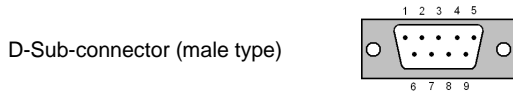

Pin #	Description	Comment
1	GND	
2	GND	
3	GND	
4	S2 out	
5	S1 out	
6	- 5V	
7	+ 5V	OP
8	+ 5V	
9	+ 5V	MMIC1

Connection ISG-207 to IDS-208:

DC-Connection:

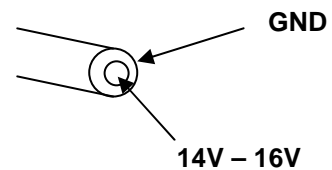
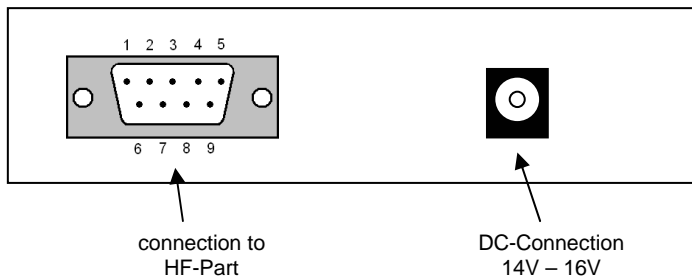

Interface for remote control ISG-207:

This interface can be used, when the switch for frequency settings is not used. Programming of individual Doppler frequencies according following verification table.

ATTENTION! For this operational mode set switch for frequency to ZERO!

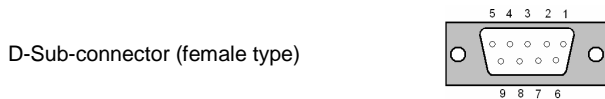

Frequency [Hz]	PIN 9	PIN 8	PIN 7	PIN 6	PIN 5
0					
44					to PIN 9
63			to PIN 9		
224			to PIN 9		to PIN 9
393				to PIN 9	
679				to PIN 9	to PIN 9
904			to PIN 9	to PIN 9	
1116			to PIN 9	to PIN 9	to PIN 9
4450		to PIN 9			
10420		to PIN 9			to PIN 9

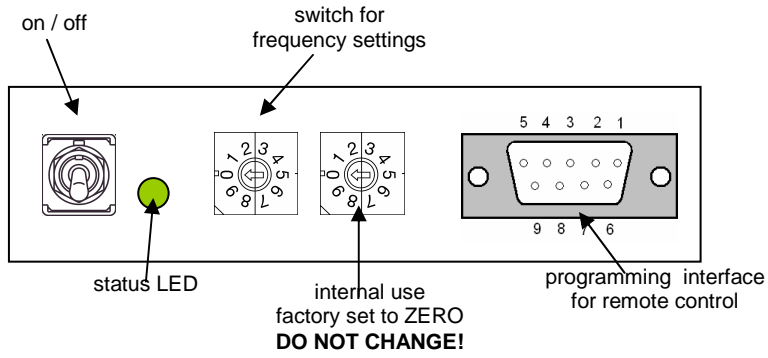

Doppler Frequencies:

Switch setting	Frequency [Hz]	Comment	
0	0	0 km/h	0 mph
1	44	1 km/h	0,63 mph
2	63	1,43 km/h	0,89 mph
3	224	5 km/h	3,11 mph
4	393	8,9 km/h	5,53 mph
5	679	15,4 km/h	9,56 mph
6	904	20,54 km/h	12,76 mph
7	1116	25,36 km/h	15,75 mph
8	4450	101,1 km/h	62,82 mph
9	10420	236,8 km/h	147,14 mph

K-Band PLL Transceiver: IVS-195

Description:

- K-Band VCO radar transceiver
- CW / FSK / FMCW applications
- advanced PHEMT-oscillator with low current consumption
- crystal based reference signal for calibration and/or PLL application
- RF-pre-amplifier for lowest noise operation
- separate transmit and receive path for maximum sensitivity
- stereo-dual-I/Q receive channels
- IF-pre-amplifier
- Instruction manual available on request

Product Picture:



Absolute Maximum Ratings:

Parameter	Symbol	Rating
positive supply voltage	V_{CC}	5.25 V
operating temperature (out of spec)	T_{OP}	- 40°C / + 85°C
storage temperature	T_{STG}	+ 90°C

Mechanical Outlines:

(dimensions in mm)

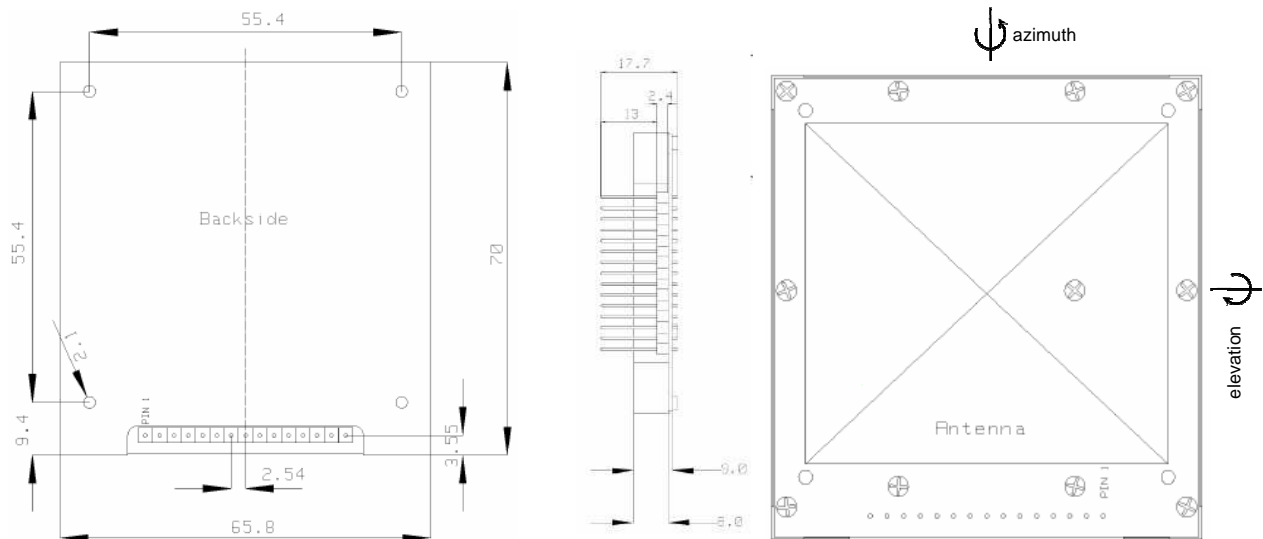

Interface:

The sensor provides a 2.54 mm grid, single row 15-pin header (square pin \square 0.635 mm).

Pin #	Description	In/Out	Comment
1	V_{tune}	input	varactor tuning voltage
2	V_{CC}	input	positive power supply for VCO, LNA, IFA (+ 5 V)
3	IF1	output	Signal I(nphase)
4	IF2	output	Signal Q(uadrature)
5	VCO_EN	input	active low (enable for VCO and LNA)
6	V_{SS}	input	negative power supply for VCO, LNA, IFA (- 5 V)
7	LD	output	Lock detect diagnostic signal
8	GND	input	analog ground
9	V_{PLL}	input	positive power supply reference circuit (+ 5 V)
10	SPI_DATA	input	programming input for PLL-IC
11	SPI_CLK	input	programming input for PLL-IC
12	NC		not connected
13	DNC		do not connect
14	SPI_EN	input	enable input for programming PLL-IC
15	Ref	output	reference signal output

Electrical Characteristics:

Parameter	Symbol	min.	typ.	Max.	units	comment
VCO						
transmit frequency	f	24.000 – 24.250			GHz	
output power	P _{out}			20	dBm	
varactor tuning voltage	V _{tune}	0.5		10	V	
tuning slope		45	75	125	MHz/V	@ V _{tune} : 4 – 6 V
varactor input impedance			4.7 kΩ, 100 pF			input circuit
modulation frequency			150		kHz	1)
temperature drift	Δf		- 1		MHz/°C	
Antenna						
antenna pattern (-3 dB)	horizontal		13	15	°	azimuth
	vertical		36	40	°	elevation
side lobe suppression	horizontal	16	20		dB	azimuth
	vertical	10	13		dB	elevation
Receiver						
IF-amplifier	gain		32		dB	
	bandwidth		35 – 180k		Hz	
output impedance			100		Ω	
signal level		9			mV _{RMS}	@ InnoSenT test setup
noise level				0.25	mV _{RMS}	@ InnoSenT test setup
voltage offset			V _{CC} /2		V	
I/Q balance	amplitude			6	dB	
	phase	60	90	120	°	
PLL Signal						
tuning range			24.000 – 24.250		GHz	
reference signal			2		dBm	@ 45 MHz Ref. freq.
Ref-amplifier bandwidth			30 – 120		MHz	maximum @ 45 MHz
startup time			1		ms	
Power supply						
positive supply voltage	V _{CC}	4.75	5.0	5.25	V	
positive supply current	I _{CC}		75	100	mA	
negative supply voltage	V _{SS}	-4.75	-5.0	-5.25	V	
negative supply current	I _{SS}		1.5	5	mA	
PLL supply voltage	V _{PLL}	4.75	5.0	5.25	V	
PLL supply current	I _{PLL}		55	70	mA	
Environment						
operating temperature	T _{OP}	- 20		+ 60	°C	
outline dimensions		~ 65.8 x 70.0 x 9 (17.7)			mm	compare drawing

1) The modulation frequency is defined as followed:

1. Determination of two static tuning voltages required for a 100 MHz sweep of the transmit frequency.
2. Generation of a square wave signal which is limited by these two voltages.
3. Application of this square wave signal to the V_{tune} input.
4. Increasing the frequency of the square wave signal until the sweep of the transmit frequency is reduced to 90 MHz.
5. The modulation frequency is the corresponding frequency of the square wave signal.

K-Band Monopulse Transceiver: IVQ-405

Description:

- K-Band VCO-Transceiver
- monopulse/CW/FSK/FMCW modes
- two receiver channels (I/Q-type) for monopulse operations
- advanced PHEMT-oscillator with low current consumption
- RF-pre-amplifier for lowest noise operation
- separate transmit and receive path for maximum sensitivity
- IF-pre-amplifier

Absolute Maximum Ratings:

Parameter	Symbol	Rating
positive supply voltage	V_{CC}	5.5 V
negative supply voltage	V_{SS}	- 5.5 V
operating temperature (out of spec)	T_{OP}	- 40°C / + 85°C
storage temperature	T_{STG}	+ 90°C

Mechanical Outlines:

(dimensions in mm)

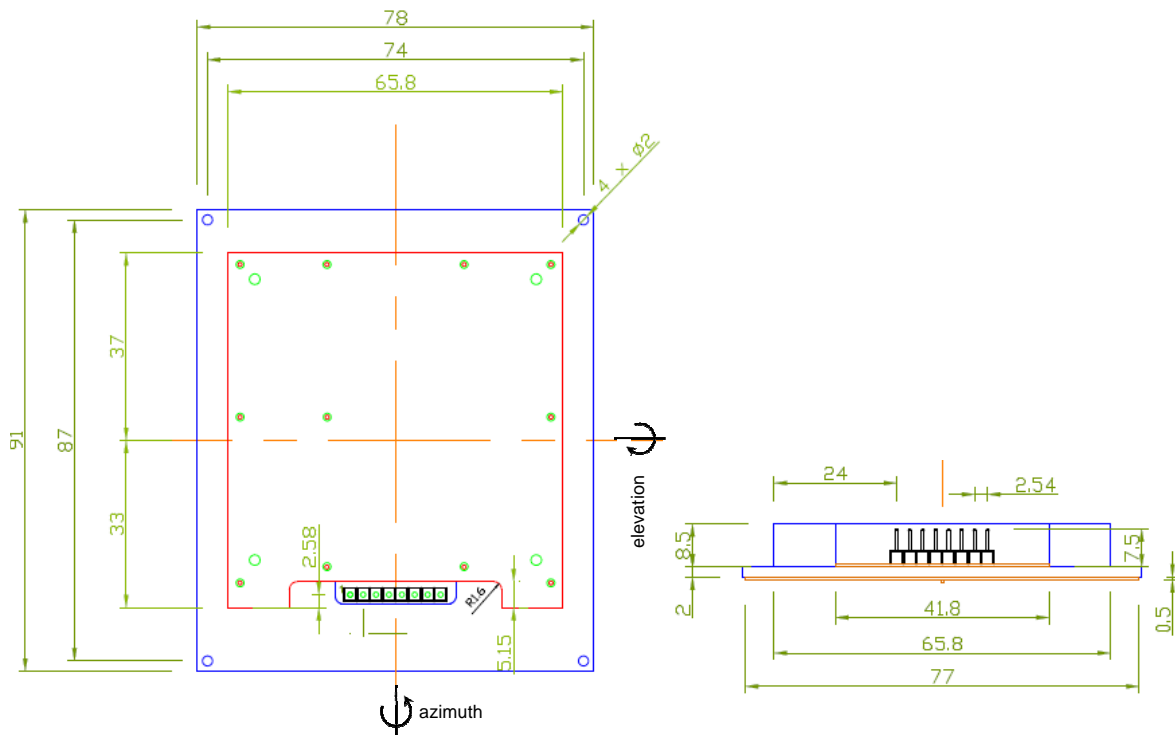

Product Picture:

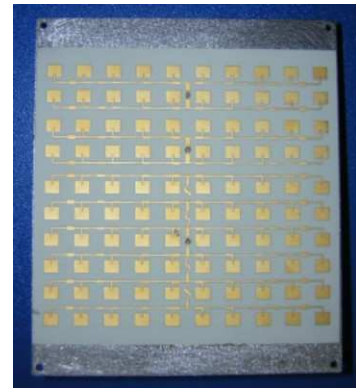

Interface:

The sensor provides a 2.54 mm grid, single row 8-pin header (square pin \square 0.635 mm).

Pin #	Description	In/Out	Comment
1	V_{tune}	input	varactor tuning voltage
2	V_{SS}	input	negative supply voltage (- 5 V)
3	V_{CC}	input	positive supply voltage (+5 V)
4	GND	input	analog ground
5	I1	output	Signal Inphase (Rx antenna 1)
6	Q1	output	Signal Quadrature (Rx antenna 1)
7	I2	output	Signal Inphase (Rx antenna 2)
8	Q2	output	Signal Quadrature (Rx antenna 2)

Electrical Characteristics:

Parameter	Symbol	min.	typ.	Max.	units	comment
VCO						
transmit frequency	f		24.000 - 24.250		GHz	depending on V _{tune}
output power (EIRP)	P _{out}		20		dBm	
varactor tuning voltage	V _{tune}	0.5		8	V	
tuning slope			50		MHz/V	
varactor input impedance			4.7		kΩ	
modulation frequency				150	kHz	
temperature drift	Δf		- 1		MHz/°C	
Antenna						
Tx antenna pattern (-3 dB)	horizontal		23		°	azimut h
	vertical		12		°	elevation
Tx side lobe suppression	horizontal		15		dB	azimuth
	vertical		15		dB	elevation
Rx antenna pattern (-3 dB)	horizontal		55		°	azimut h
	vertical		12		°	elevation
Rx side lobe suppression	horizontal		10		dB	azimuth
	vertical		15		dB	elevation
Receiver						
IF-amplifier	gain		33		dB	
	bandwidth		50 – 220k		Hz	
voltage offset			V _{CC} /2		V	
I/Q balance	amplitude			6	dB	
	phase	60	90	120	°	
Power supply						
positive supply voltage	V _{CC}	4.75	5.0	5.25	V	
positive supply current	I _{CC}		75		mA	IF-amp. Included
negative supply voltage	V _{SS}	-5.25	-5.0	-4.75	V	
negative supply current	I _{SS}		2		mA	
Environment						
operating temperature	T _{OP}	- 20		+ 60	°C	
outline dimensions		~ 91 x 78 x 11			mm	compare drawing

Appendix A: Antennendiagramme / antenna patterns

K-Band Transceiver

<u>model</u>	<u>no. of antennas</u>	<u>antenna pattern [°]</u>		<u>side lobe suppr. [dB]</u>	<u>comment</u>	<u>page</u>
		horiz.	Vert.			
IPS-144	2	12	25	H = 20 / V = 13		31
IPS-146	2	30	32	typ. 20		32
IPS-154	2	45	38	typ. 13		33
IPS-155	2	70	36	typ. 13		34
IPS-168	2	5	21	max. 15		35

K-Band VCO-Transceiver

<u>model</u>	<u>no. of antennas</u>	<u>antenna pattern [°]</u>		<u>side lobe suppr. [dB]</u>	<u>comment</u>	<u>page</u>
		horiz.	Vert.			
IVS-148	2	12	25	typ. 15		31
IVS-162	2	45	38	typ. 13		33
IVS-163	2	70	36	typ. 13		34
IVS-167	1	11	11	typ. 15		36
IVS-179	2	7	28	typ. 15		37

Universal Low-Cost radar transceivers

<u>model</u>	<u>no. of antennas</u>	<u>antenna pattern [°]</u>		<u>side lobe suppr. [dB]</u>	<u>comment</u>	<u>page</u>
		horiz.	Vert.			
IPM-165	2	80	32	typ. 13		38
IPM-170	2	70	70	typ. 13		39
IPM-365	2	80	32	typ. 13		38
IPM-190	2	$\lambda/4$ dipole rod antennas				40

Special Products

<u>model</u>	<u>antenna</u>	<u>antenna pattern [°]</u>		<u>side lobe suppr. [dB]</u>	<u>comment</u>	<u>page</u>
		horiz.	vert.			
IPB-114	1	31	15	typ. 18	Barrier	41
IVS-195	2	13	36	H = 20 / V = 13	PLL	42
IVQ-405	3	55 23	12 12	H = 10 / V = 15 typ. 15	RX TX	43

K-Band Transceiver: IPS-144

K-Band VCO Transceiver: IVS-148

Polardiagramm / radiation pattern

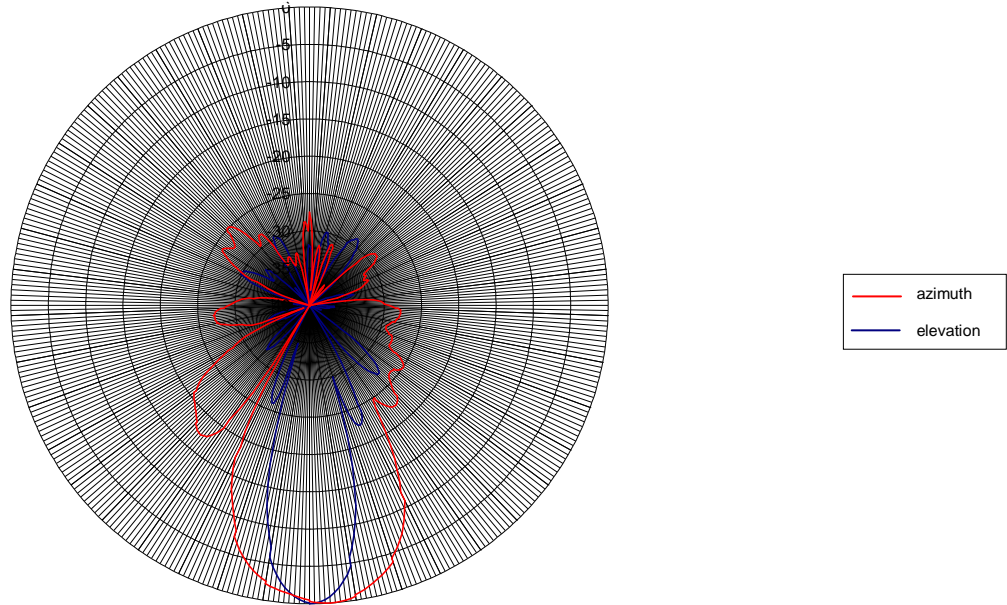

Richtdiagramm / radiation pattern

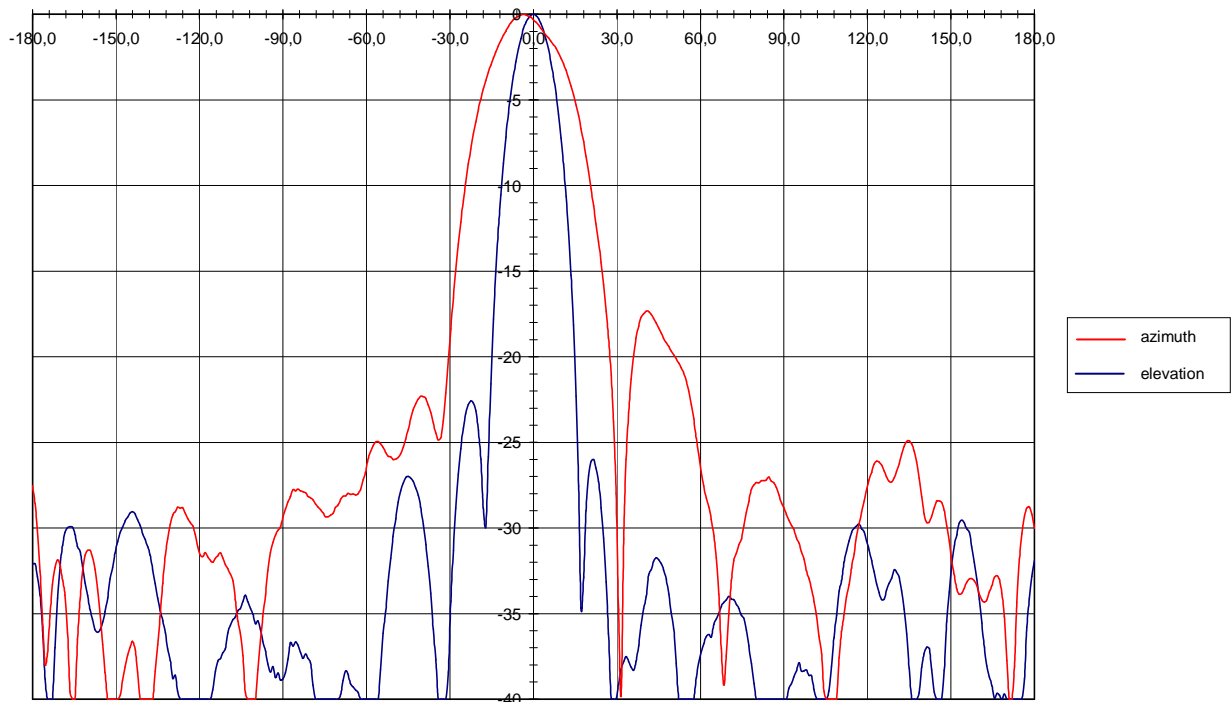

Parameter	Symbol	min	typ.	max.	units	comment
antenna pattern	horizontal		12		°	azimuth
	vertical		25		°	elevation
side lobe level	horizontal		-20		dB	azimuth
	vertical		-13		dB	elevation

K-Band Transceiver: IPS-146

Polardiagramm / radiation pattern

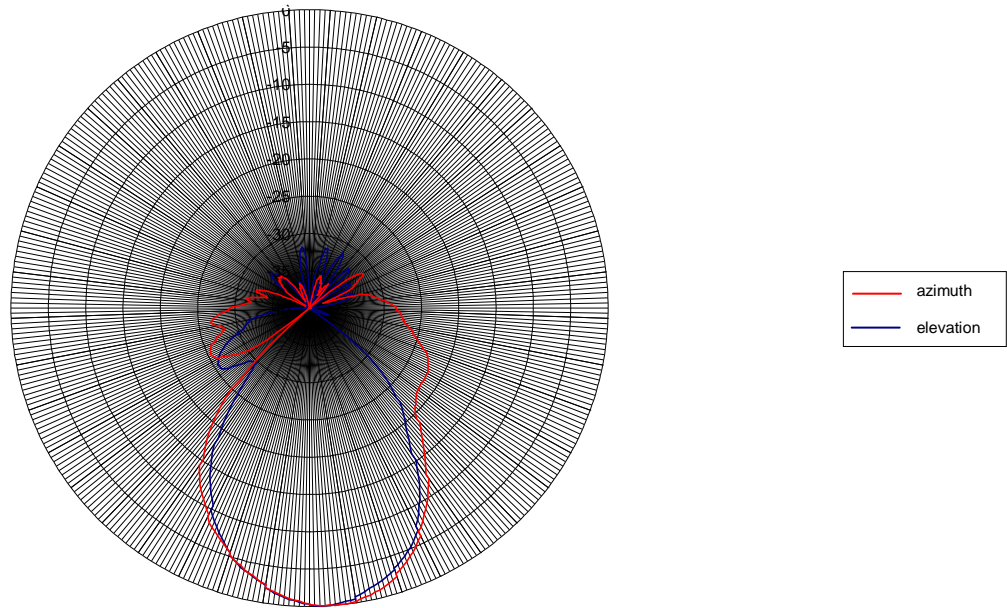

Richtdiagramm / radiation pattern

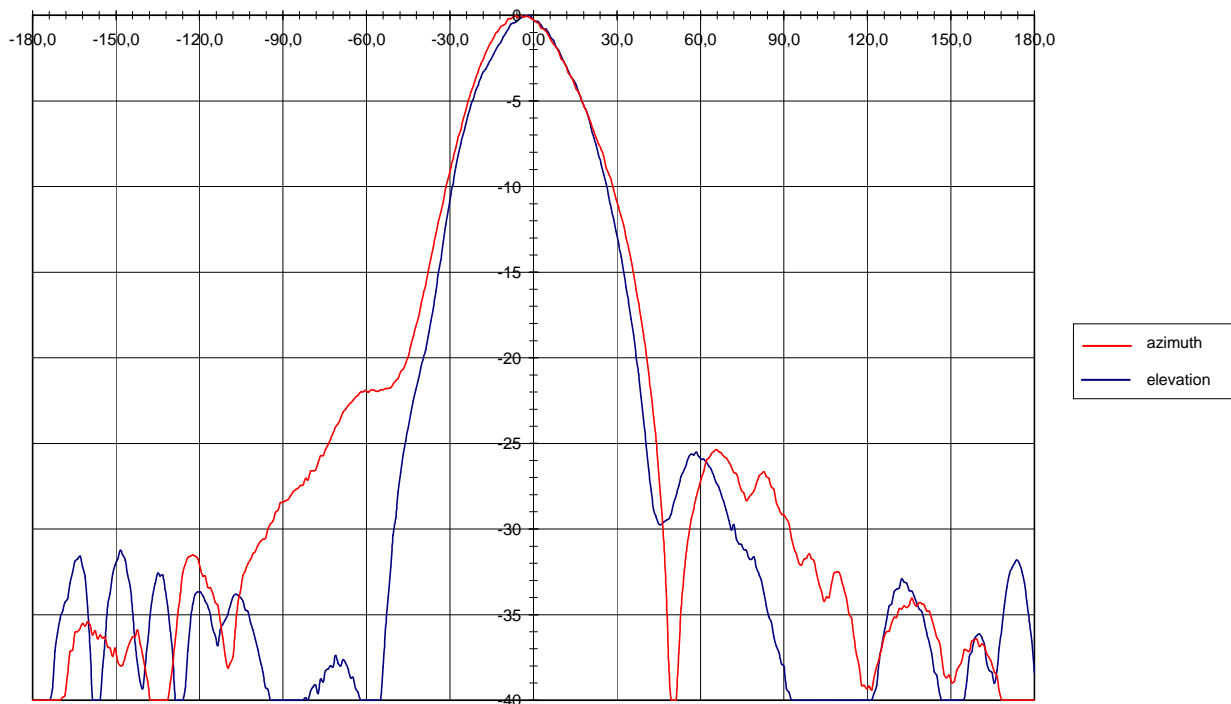

Parameter	Symbol	min	typ.	max.	units	comment
antenna pattern	horizontal		30		°	azimuth
	vertical		32		°	elevation
side lobe level	horizontal		-20		dB	azimuth
	vertical		-20		dB	elevation

K-Band Transceiver: IPS-154 K-Band VCO Transceiver: IVS-162

Polardiagramm / radiation pattern

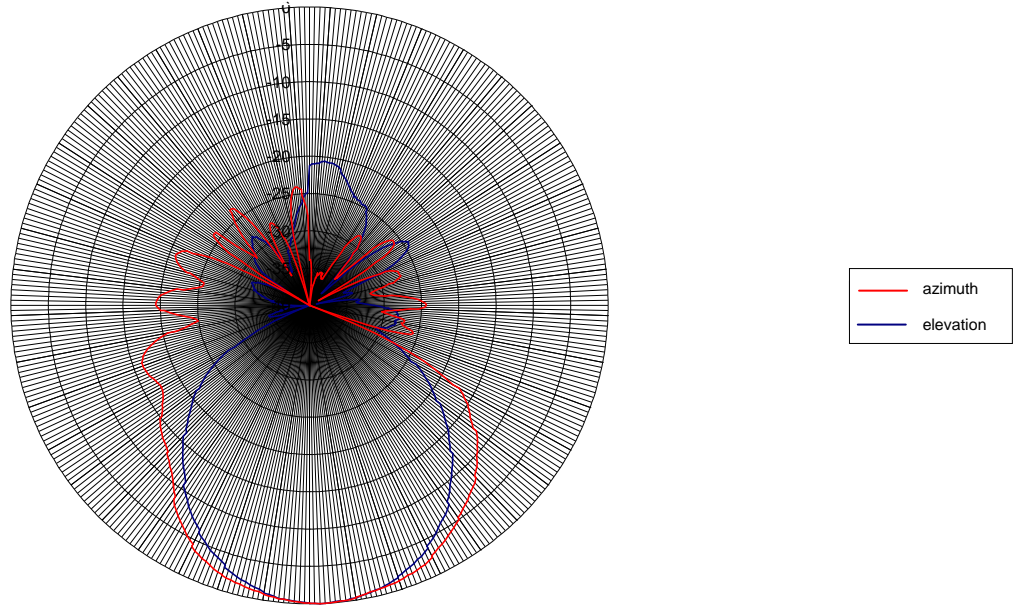

Richtdiagramm / radiation pattern

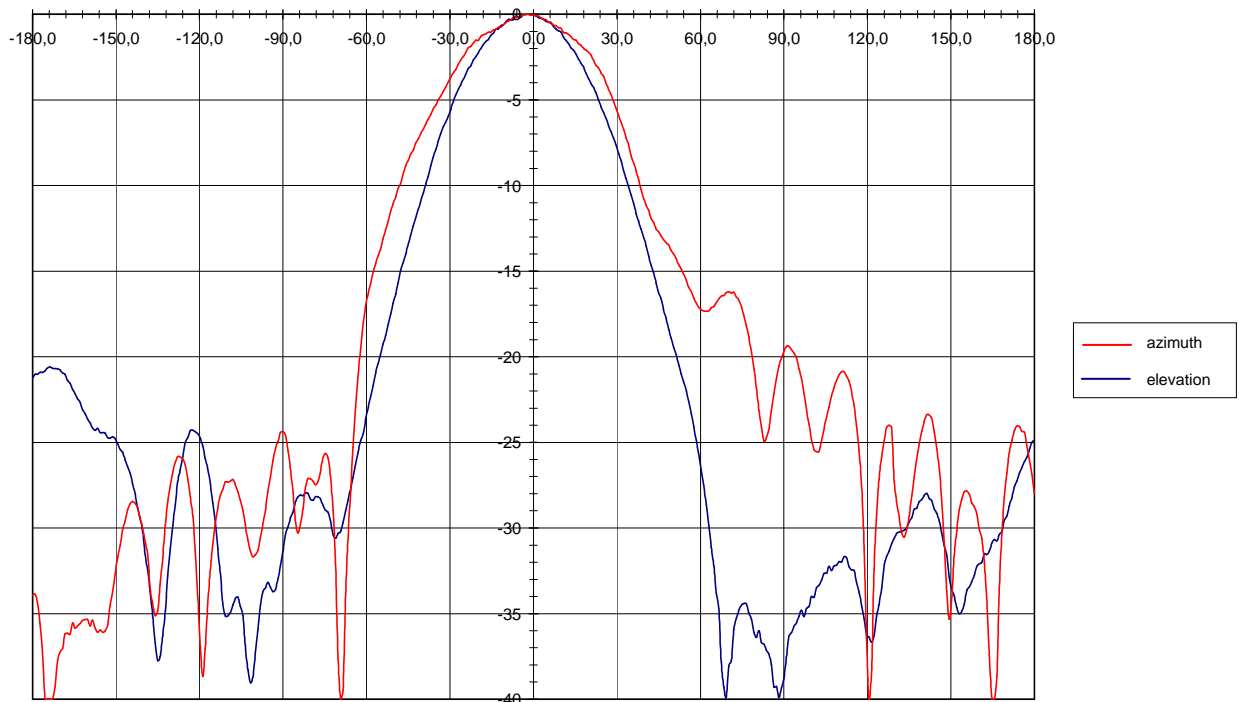

Parameter	Symbol	min	typ.	max.	units	comment
antenna pattern	horizontal		45		°	azimuth
	Vertical		38		°	elevation
side lobe suppression	horizontal		13		dB	azimuth
	Vertical		13		dB	elevation

K-Band Transceiver: IPS-155

K-Band VCO Transceiver: IVS-163

Polardiagramm / radiation pattern

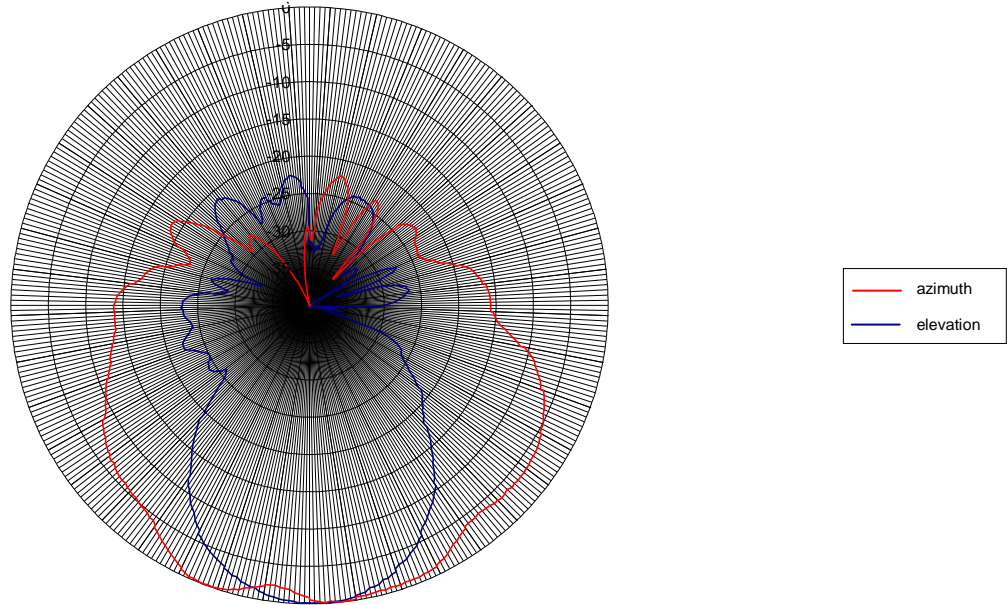

Richtdiagramm / radiation pattern

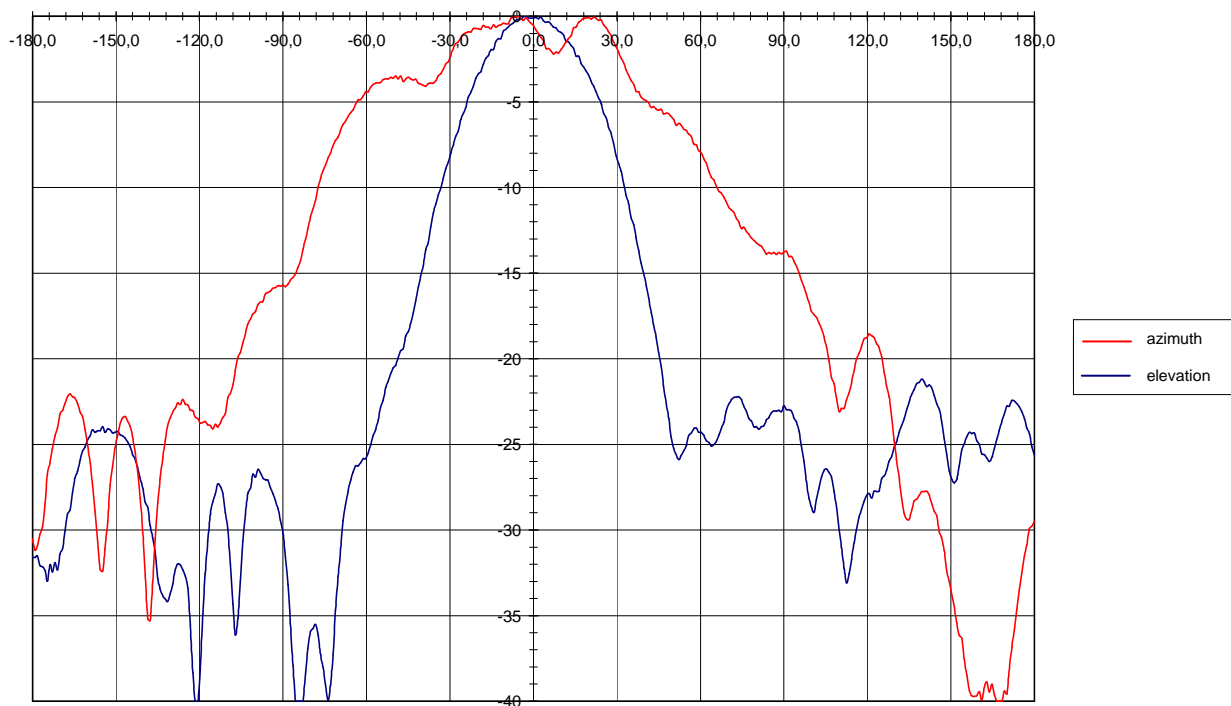

Parameter	Symbol	min	typ.	max.	units	comment
antenna pattern	horizontal		70		°	azimuth
	Vertical		36		°	elevation
side lobe suppression	horizontal		13		dB	azimuth
	vertical		13		dB	elevation

K-Band Transceiver: IPS-168

Polardiagramm / radiation pattern

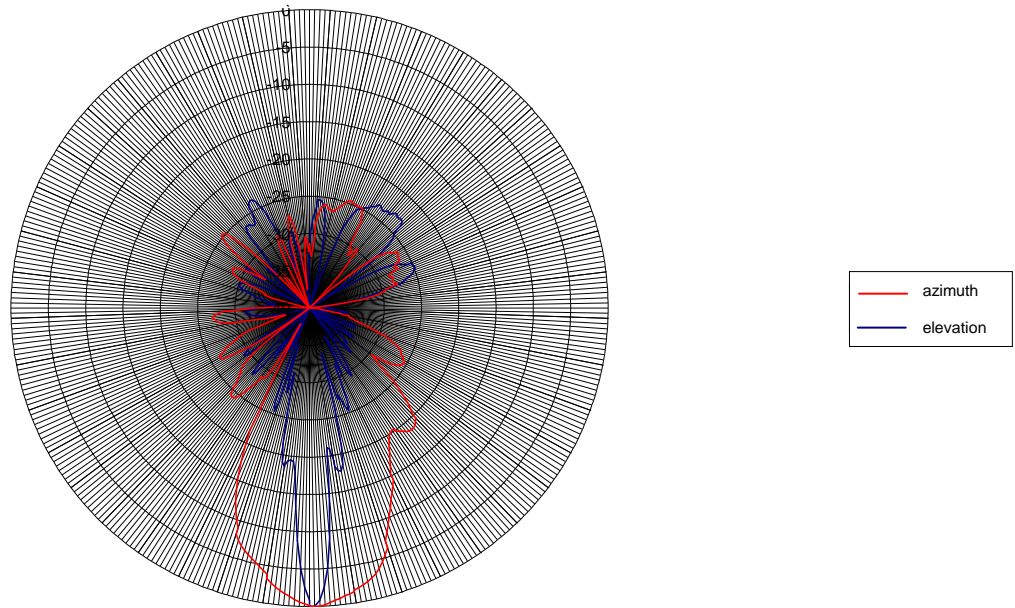

Richtdiagramm / radiation pattern

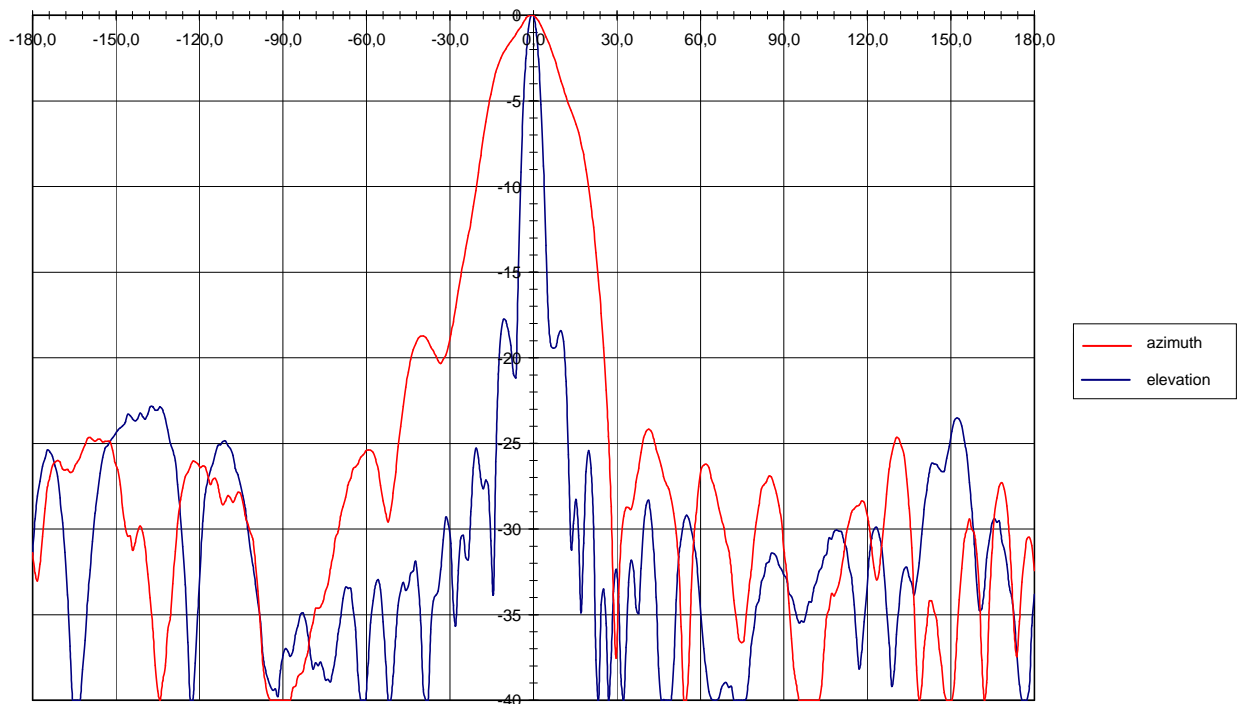

Parameter	Symbol	min	typ.	max.	units	comment
antenna pattern	horizontal		5		°	azimuth
	vertical		21		°	elevation
side lobe level	horizontal			-15	dB	azimuth
	vertical			-15	dB	elevation

K-Band VCO Transceiver: IVS-167

Polardiagramm / radiation pattern

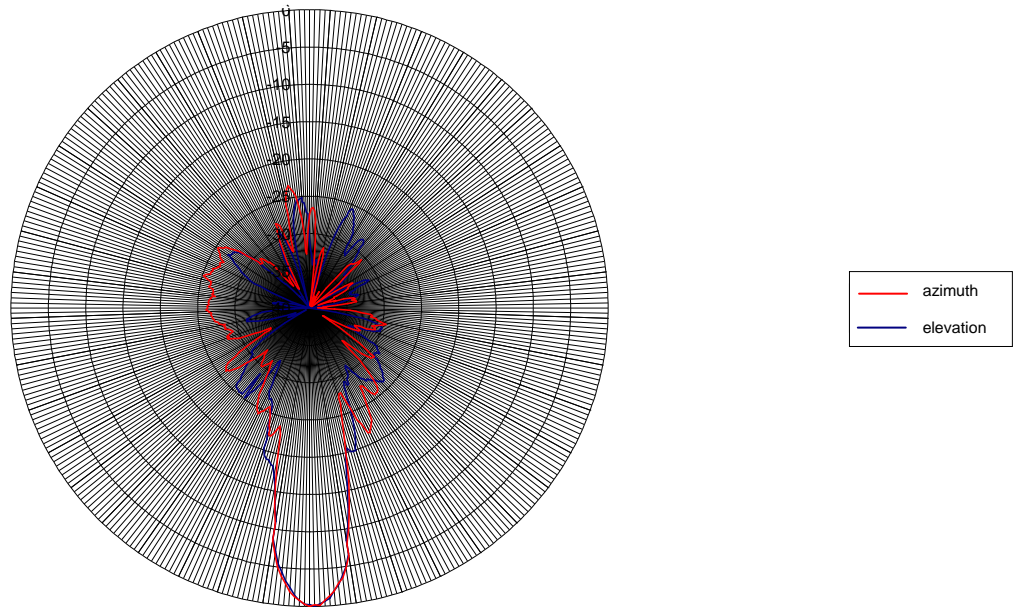

Richtdiagramm / radiation pattern

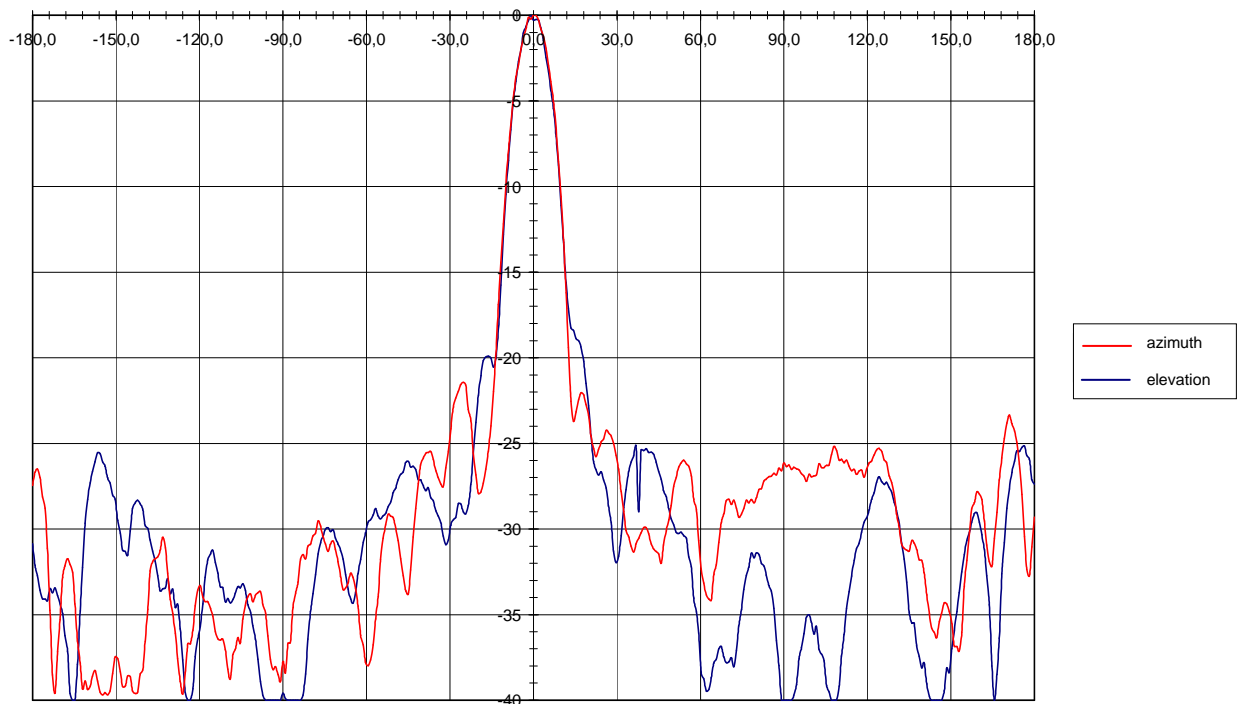

Parameter	Symbol	min	typ.	max.	units	comment
antenna pattern	horizontal		11		°	azimuth
	vertical		11		°	elevation
side lobe suppression	horizontal		15		dB	azimuth
	vertical		15		dB	elevation

K-Band VCO Transceiver: IVS-179

Polardiagramm / radiation pattern

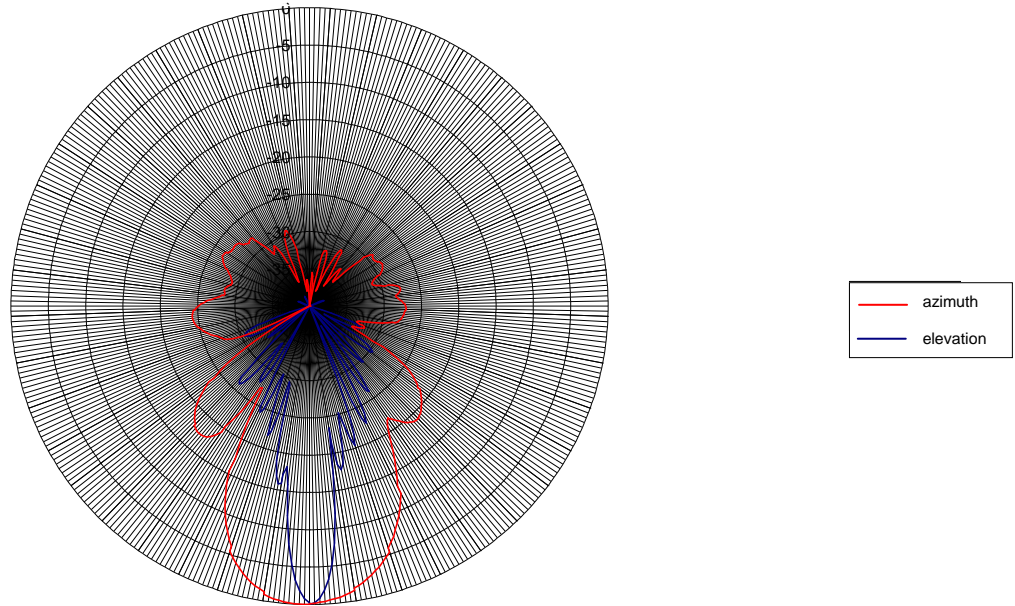

Richtdiagramm / radiation pattern

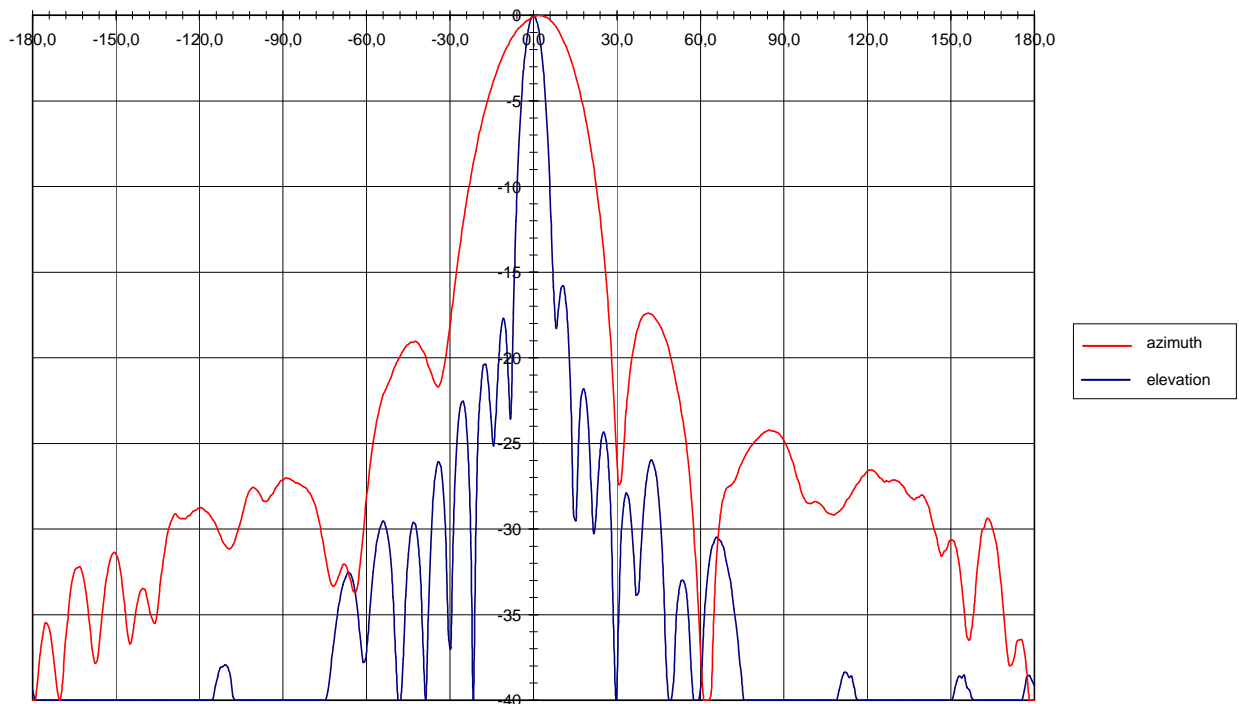

Parameter	Symbol	min	typ.	max.	units	comment
antenna pattern	horizontal		7		°	azimuth
	vertical		28		°	elevation
side lobe level	horizontal		15		dB	azimuth
	vertical		15		dB	elevation

Low-Cost K-Band Transceiver: IPM-165 / IPM-365

Polardiagramm / radiation pattern

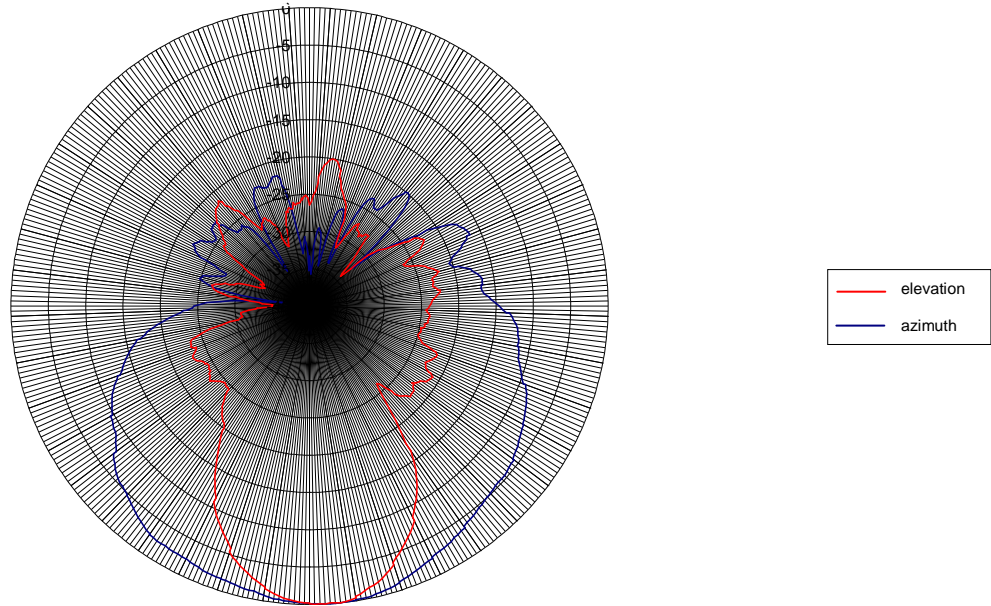

Richtdiagramm / radiation pattern

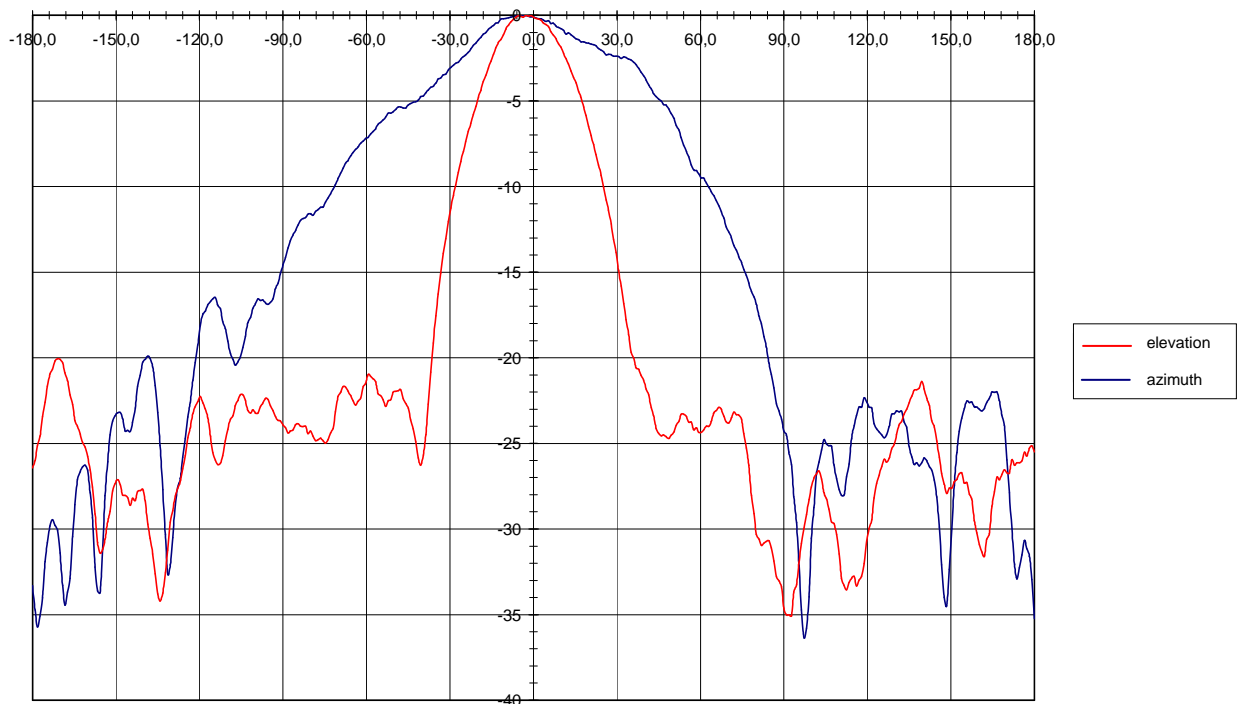

Parameter	Symbol	min	typ.	max.	units	comment
antenna pattern	horizontal		80		°	azimuth
	vertical		32		°	elevation
side lobe suppression	horizontal		13		dB	azimuth
	vertical		13		dB	elevation

Low-Cost K-Band Transceiver: IPM-170

Polardiagramm / radiation pattern

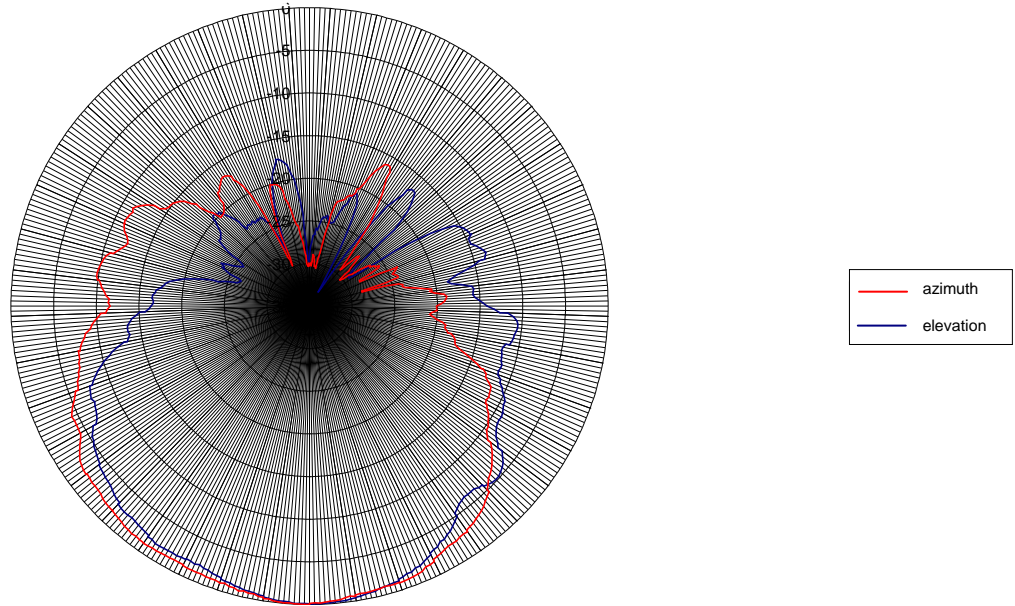

Richtdiagramm / radiation pattern

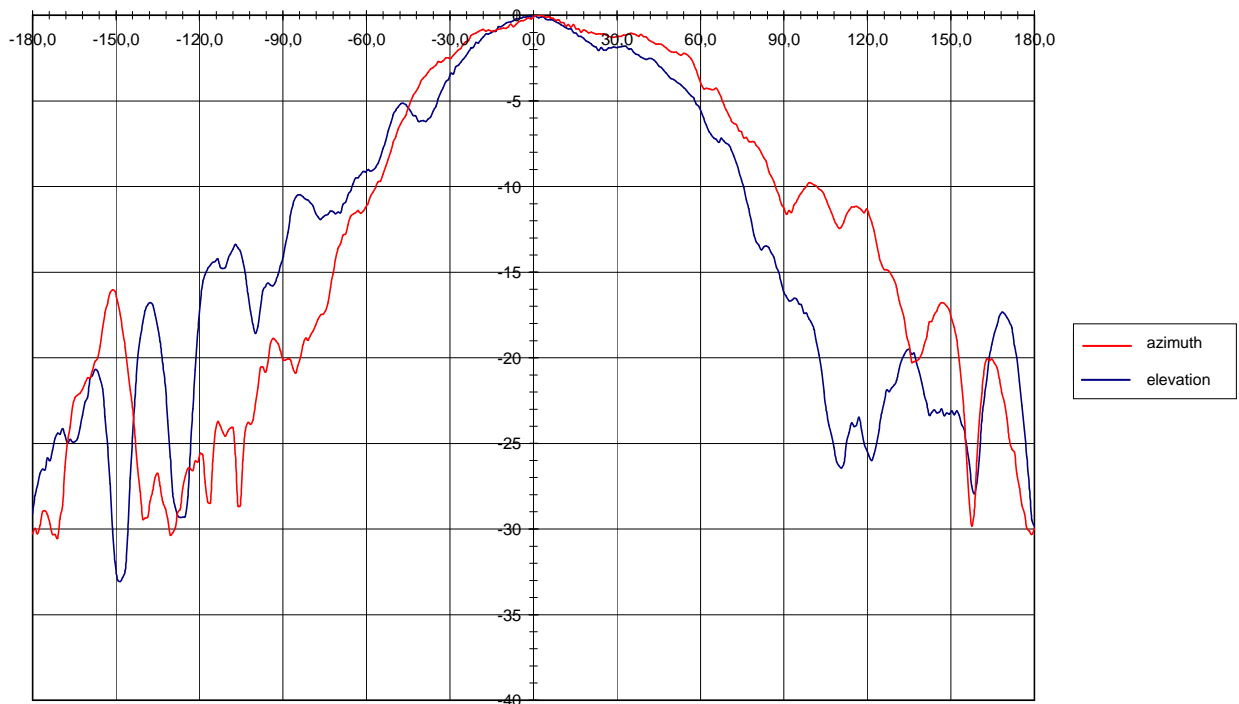

Parameter	Symbol	min	typ.	max.	units	comment
antenna pattern	horizontal		70		°	azimuth
	vertical		70		°	elevation
side lobe suppression	horizontal		13		dB	azimuth
	vertical		13		dB	elevation

Low K-Band Transceiver: IPM-190

Polardiagramm / radiation pattern

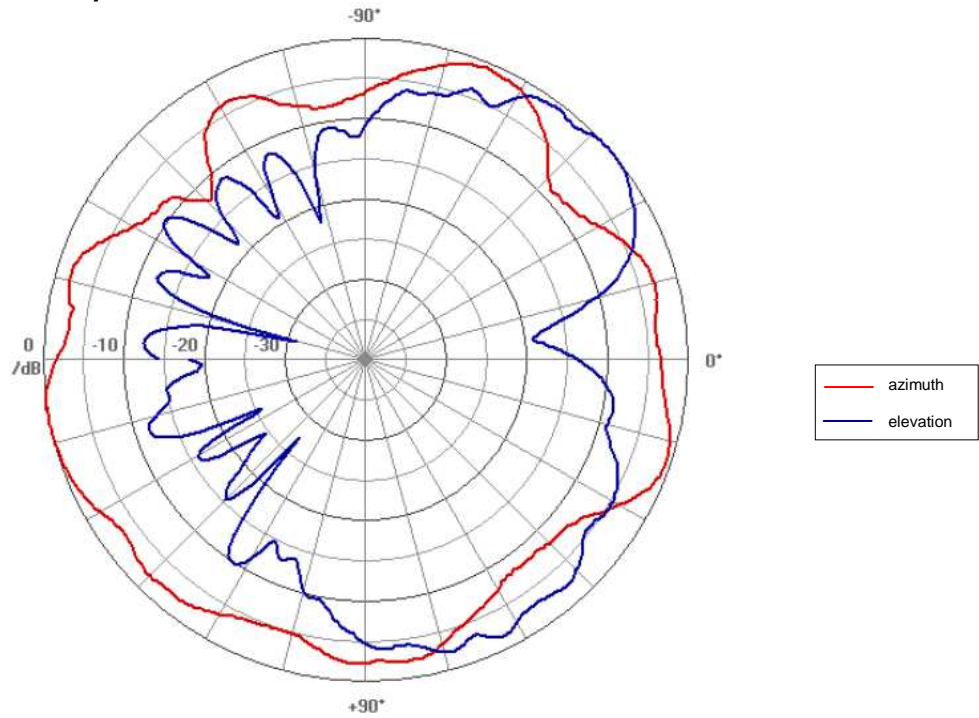

Richtdiagramm / radiation pattern

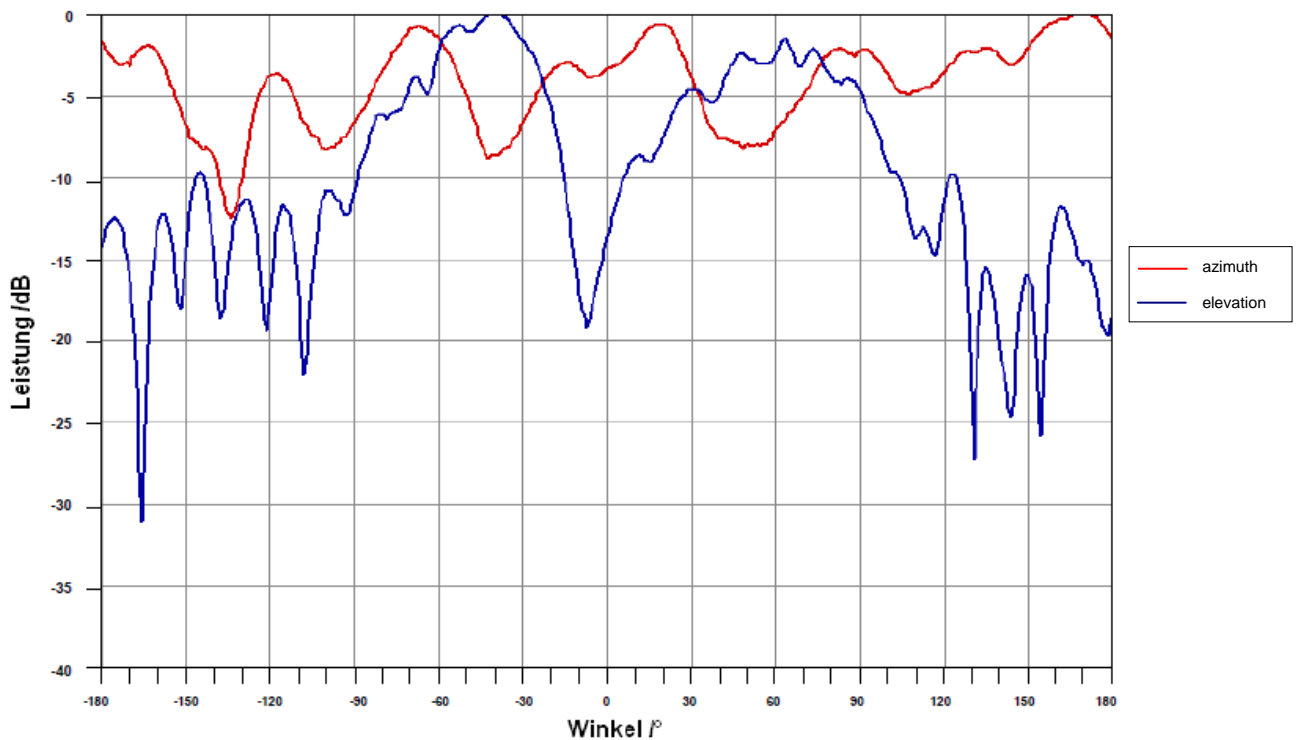

Parameter	Symbol	min	typ.	max.	units	comment
antenna pattern	horizontal	$\lambda/4$ dipole rod antenna				azimuth
	vertical					elevation
side lobe suppression	horizontal	$\lambda/4$ dipole rod antenna				azimuth
	vertical					elevation

K-Band Barrier: IPB-114

Polardiagramm / radiation pattern

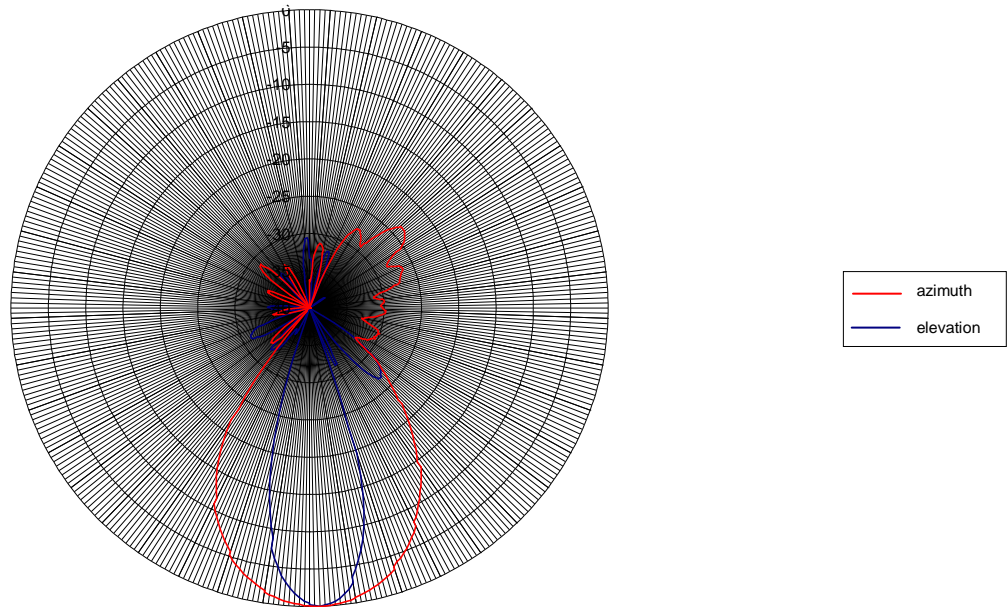

Richtdiagramm / radiation pattern

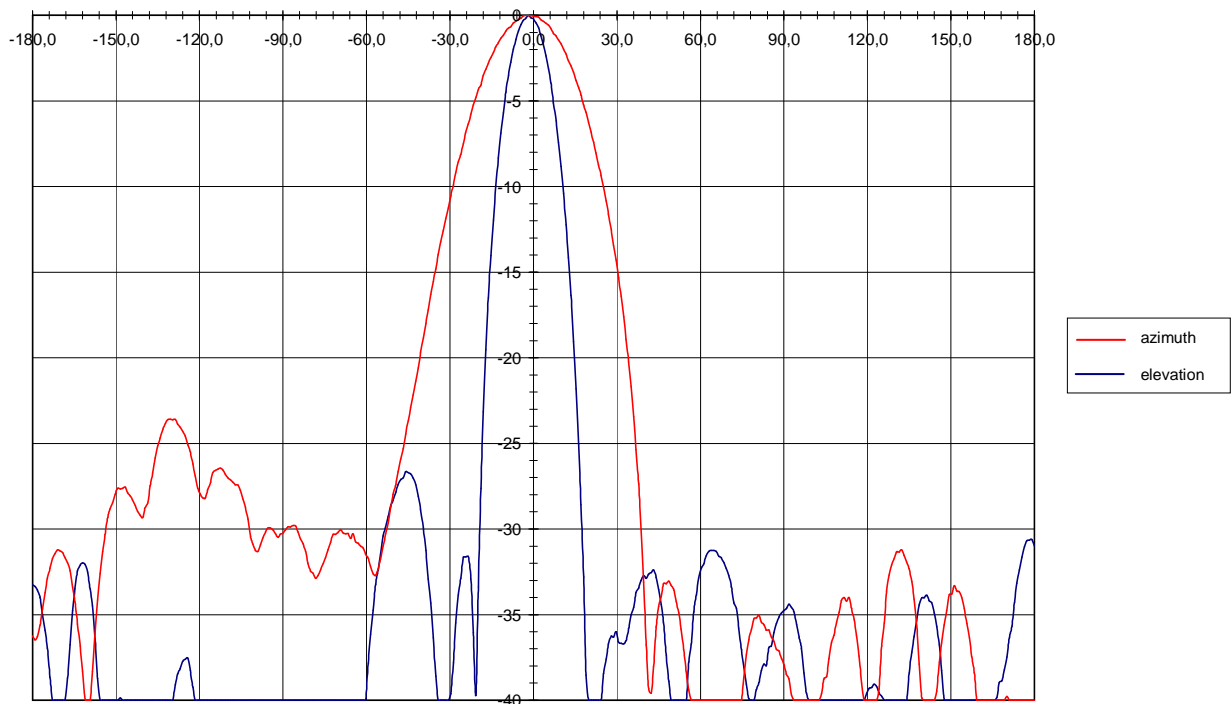

Parameter	Symbol	min	typ.	max.	units	comment
antenna pattern	horizontal		31		°	azimuth
	vertical		15		°	elevation
	side lobe suppression		18		dB	

K-Band PLL Transceiver IVS-195

Polardiagramm / radiation pattern

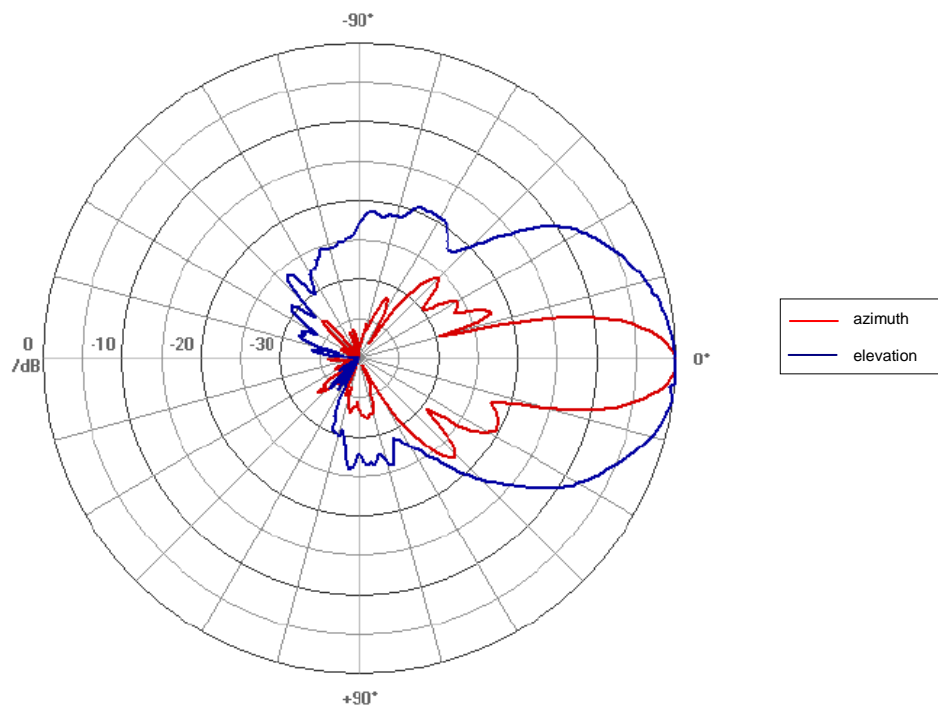

Richtdiagramm / radiation pattern

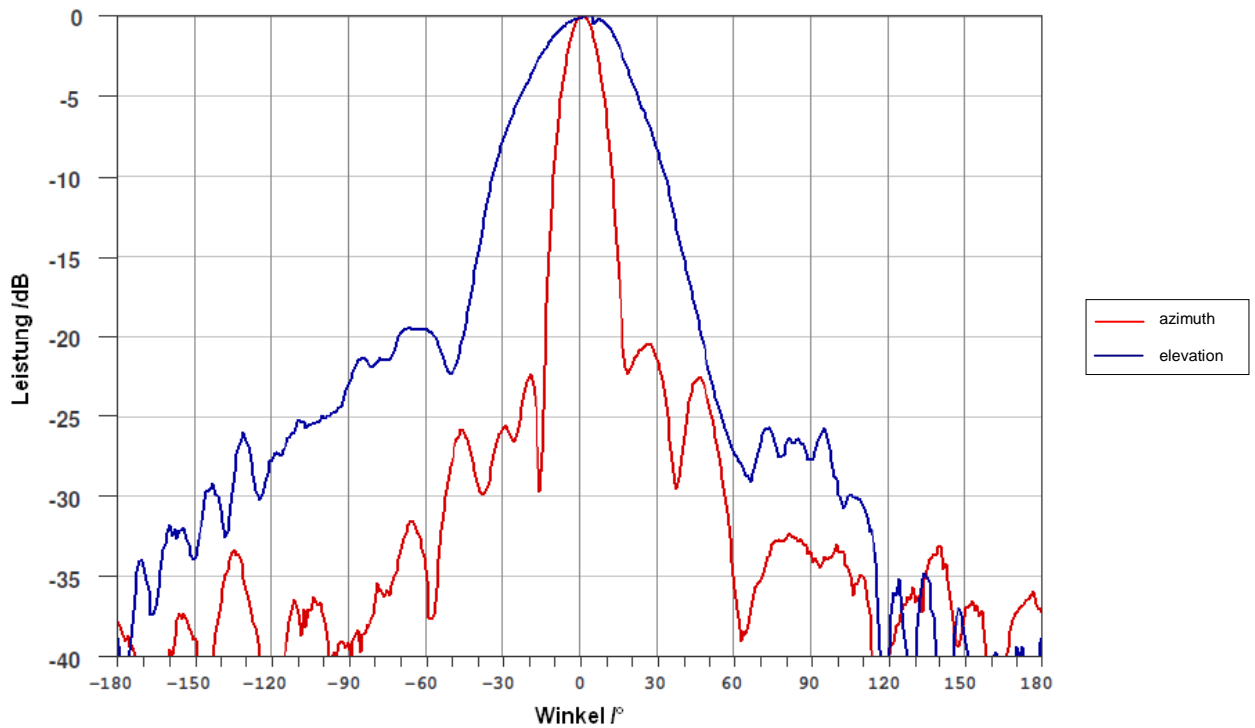

Parameter	Symbol	min	typ.	max.	units	comment
antenna pattern	horizontal		13	15	°	azimuth
	vertical		36	40	°	elevation
side lobe suppression	horizontal	16	20		dB	azimuth
	vertical	10	13		dB	elevation

K-Band Monopulse Transceiver: IVQ-405

Richtdiagramm Tx / radiation pattern Tx

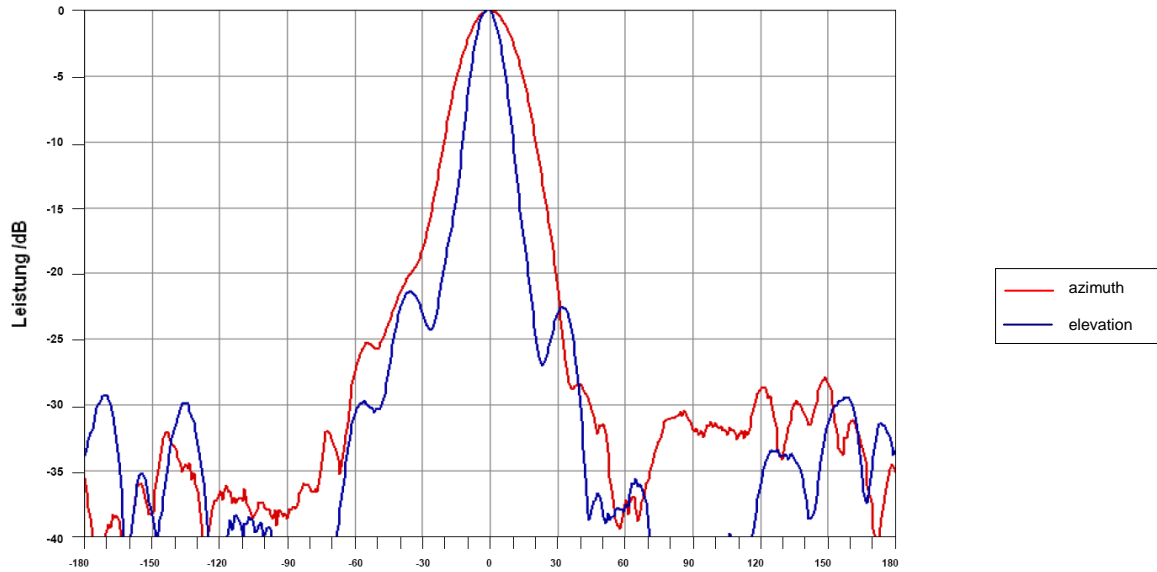

Richtdiagramm Rx / radiation pattern Rx

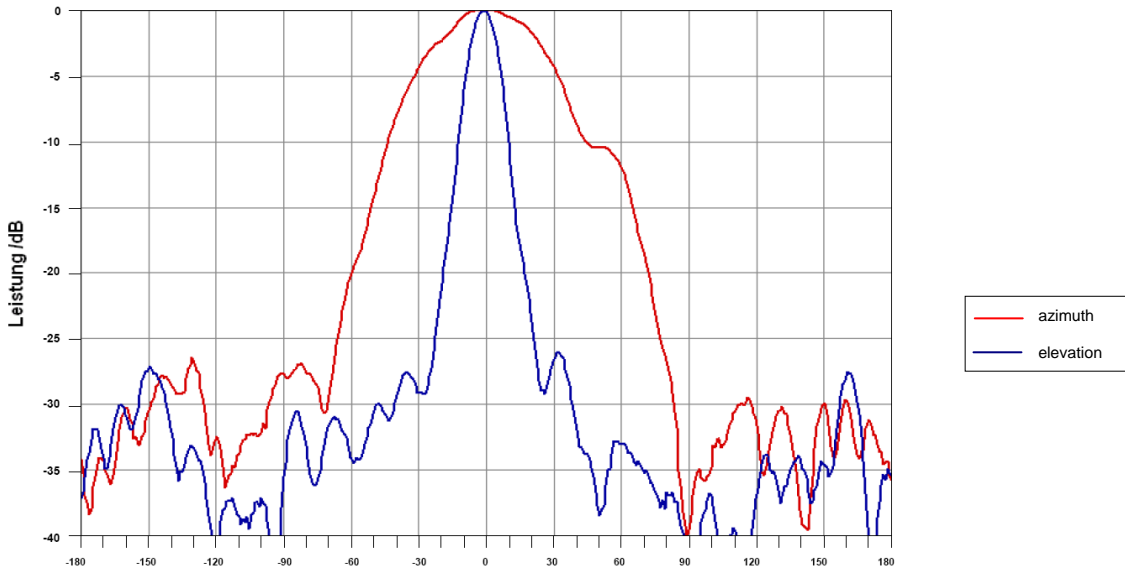

Parameter	Symbol	min	typ.	max.	units	comment
antenna pattern Tx	horizontal		23		°	azimuth
	vertical		12		°	elevation
side lobe level Tx	horizontal		15		dB	azimuth
	vertical		15		dB	elevation
antenna pattern Rx	horizontal		55		°	azimuth
	vertical		12		°	elevation
side lobe level Rx	horizontal		10		dB	azimuth
	vertical		15		dB	elevation

Sie haben Fragen zu unseren Produkten?

- have you got further questions regarding our products?

Unter den unten aufgeführten Adressen können Sie gerne mit uns Kontakt aufnehmen:
You can contact us under following addresses:

Firmensitz - Headquarter

InnoSenT GmbH
Am Roedertor 30
97499 Donnersdorf
Germany

Tel.: +49-9528-9518-0
Fax.: +49-9528-9518-0
E-Mail: info@innosent.de
Web: www.innosent.de

International

Tom Aspell - International Sales Manager
InnoSenT GmbH

Tel: +44 (0)1279 439392
Fax: +44 (0)1279 439267
E-mail: tom.aspell@innosent.de
Mobile: +44 (0)7793 586173

Representatives

Territory: All Benelux Countries

Hi-Tech Electronic Components B.V.
Harmonieplein 1, PO box 277
3600 AG Maarssen,
THE NETHERLANDS

Telephone: +31 (0)346 566024
Fax: +31 (0)346 568124
E-mail: information@hitechbv.nl
Web site: www.hitechbv.nl

Territory: Italy

Consystem s.r.l.
Via E. Majorana 4,
20054 Nova Milanese,
ITALY

Telephone: +39 (0)362 364271
Fax: +39 (0)362 364282
E-mail: info@consystem.it
Web site: www.consystem.it
Contact name: Paolo Corbetta

Territory: Spain and Portugal

Vision Electro Optica S.L.
Pasaje Garrofers, 14 Atc.
08041 Barcelona,
SPAIN

Telephone: +34 (0)93 246 4545
Fax: +34 (0)93 246 5509
E-mail: key@comercialkey.com
Contact: Emilio Navarro

Territory: Eastern Europe

Atlantese
Schuilenburg 72
8926 KS Leeuwarden
THE NETHERLANDS

Telephone: +31 (0)582 672 382
Fax: +31 (0)582 651 608
E-mail: patrick.gardner@atlantese.com

Territory: France

Alain Talbi
193 Boulevard Brune
75014 Paris
FRANCE

Telephone: +33 (0)1 4044 6225
Fax: +33 (0)1 4044 0410
E-mail: atalbi@wanadoo.fr

Territory: Sweden, Finland, Norway & Denmark

MicroComp-Nordic AB
Friparksvägen 3
14638 Tullinge
SWEDEN

Telephone: +46 (0)8 607 3910
Fax: +46 (0)8 607 3911
E-mail: jan.aberg@microcomp-nordic.se

Territory: Israel

Impact Electronics Limited
Beith Korex
10 Zarchin Street
Industrial Zone, Raanana
P.O.Box 436, Raanana 43104
ISRAEL

Telephone: +972 (0)9 7446610
Fax: +972 (0)9 7446620
E-mail: impact@impactel.co.il
Contact: Yossi Cohen

