

AT8010 Series (Preliminary)

Multilayer Chip Antenna

Features

- ❖ Monolithic SMD with small, low-profile and light-weight type.
- ❖ Wide bandwidth

Applications

- ❖ 2.4GHz WLAN, Home RF, Bluetooth Modules, etc.



Specifications

Part Number	Frequency Range (MHz)	Peak Gain (dBi typ.)	Average Gain (dBi typ.)	VSWR	Impedance
AT8010-E2R9HAA_	2400~2500	2.5 (XZ-V)	0.5 (XZ-V)	2 max.	50 Ω

Q'ty/Reel (pcs) : 1,000 pcs
 Operating Temperature Range : -40 ~ +85 °C
 Storage Temperature Range : +5 ~ +35 °C, Humidity 45~75%RH
 Storage Period : 12 months max.
 Power Capacity : 3W max.

Part Number

AT 8010 - E 2R9 HAA □
 ① ② ③ ④ ⑤ ⑥

① Type	AT : Antenna	② Dimensions (L × W)	8.0 × 1.0 mm
③ Material Code	E	④ Frequency Range	2R9=2900MHz
⑤ Specification Code	HAA	⑥ Packaging	T: Tape & Reel B: Bulk

Terminal Configuration

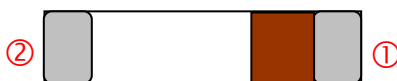

No.	Terminal Name	No.	Terminal Name
①	Feeding Point	②	NC

Dimensions and Recommended PC Board Pattern

Unit : mm

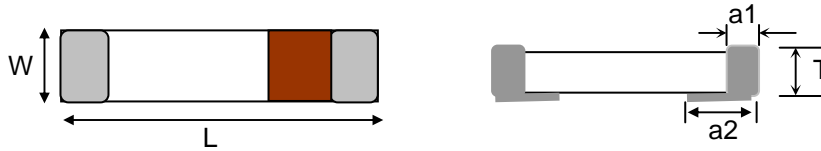

Mark	L	W	T	a1	a2
Dimensions	8.0±0.2	1.0±0.2	1.0±0.2	0.5±0.2	1.0±0.2

The Recommended PC Board layout – Type A

❖With Matching Circuits (Unit in mm)

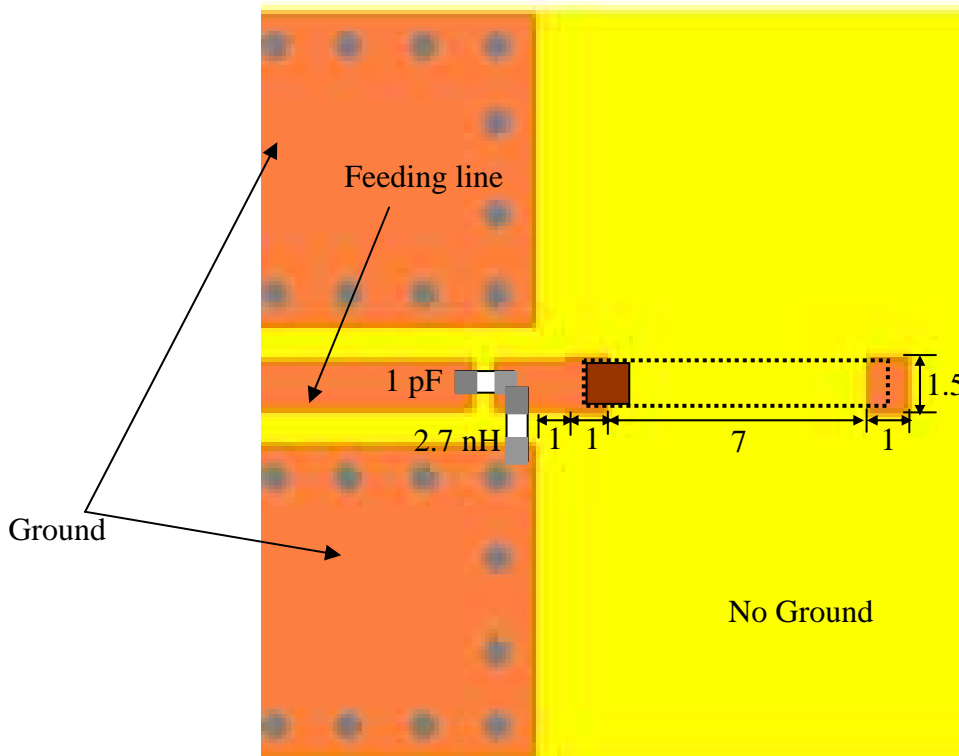

(Matching circuit and component values will be different, depending on PCB layout)

*Line width should be designed to match 50Ω characteristic impedance, depending on PCB

material and thickness.

Typical Electrical Characteristics (T=25°C)

❖ Test Board – Type A (Unit in mm)

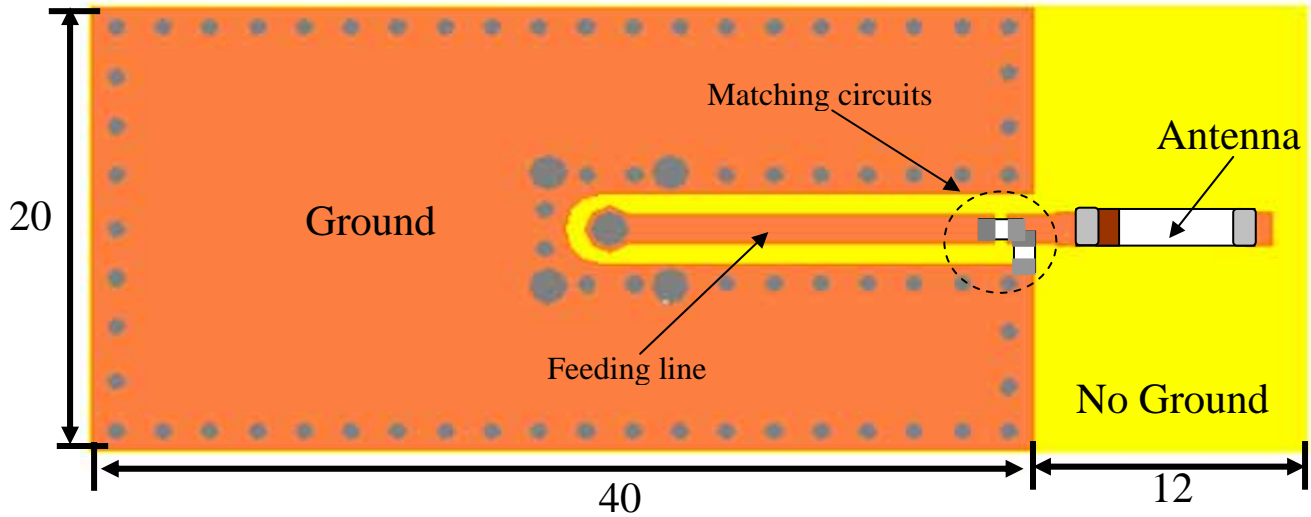

❖ Return Loss / With Matching Circuits

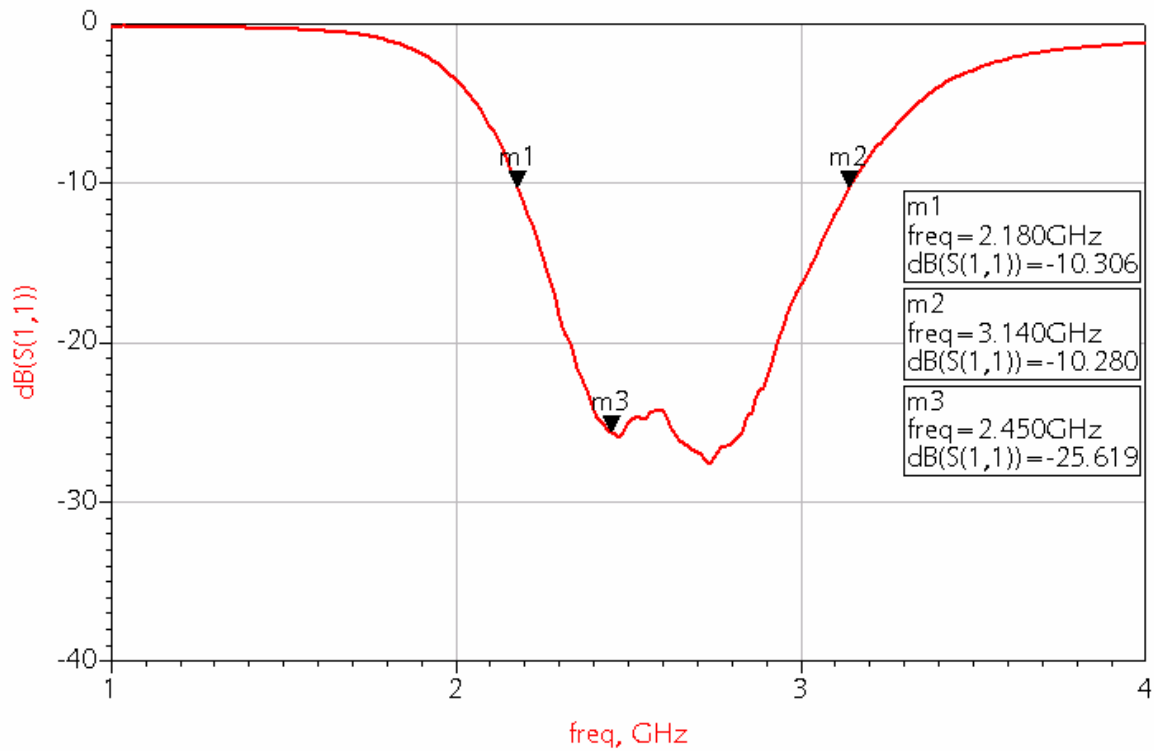

❖ Radiation Patterns

XY-V/XY-H

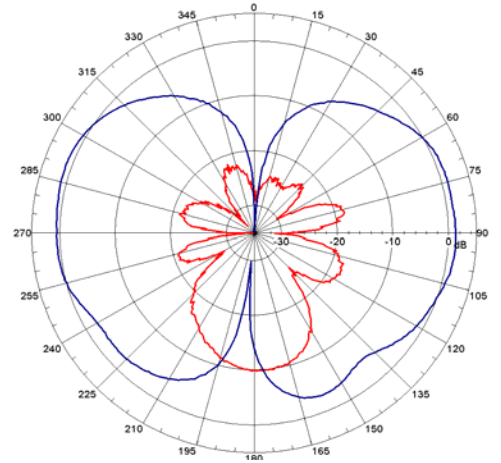
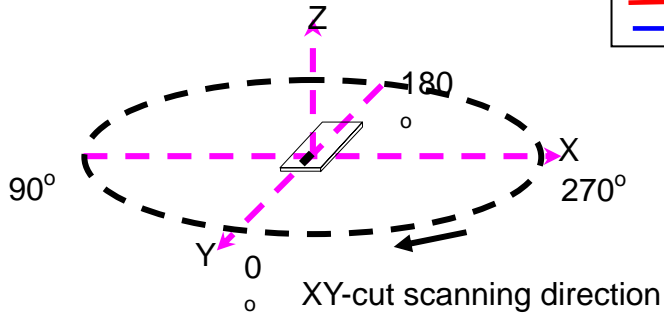

XZ-V/XZ-H

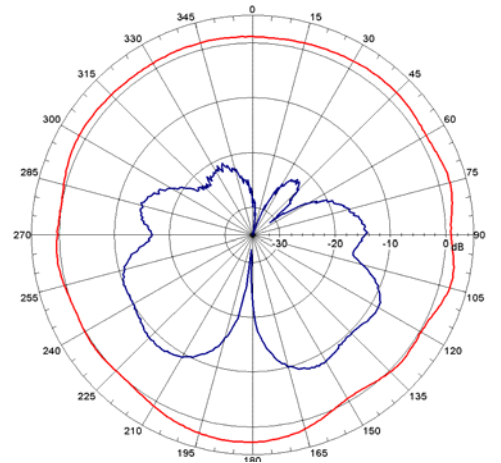
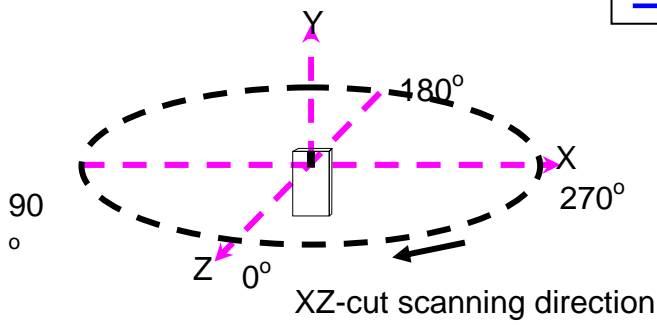

YZ-V/YZ-H

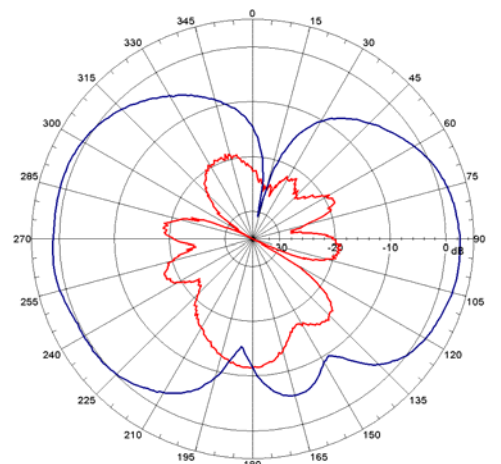
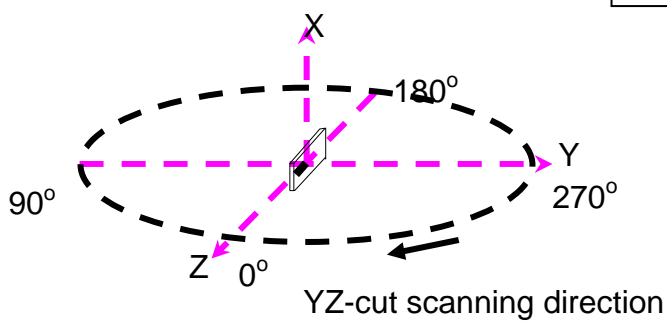

The Recommended PC Board layout – Type B

❖ With Matching Circuits (Unit in mm)

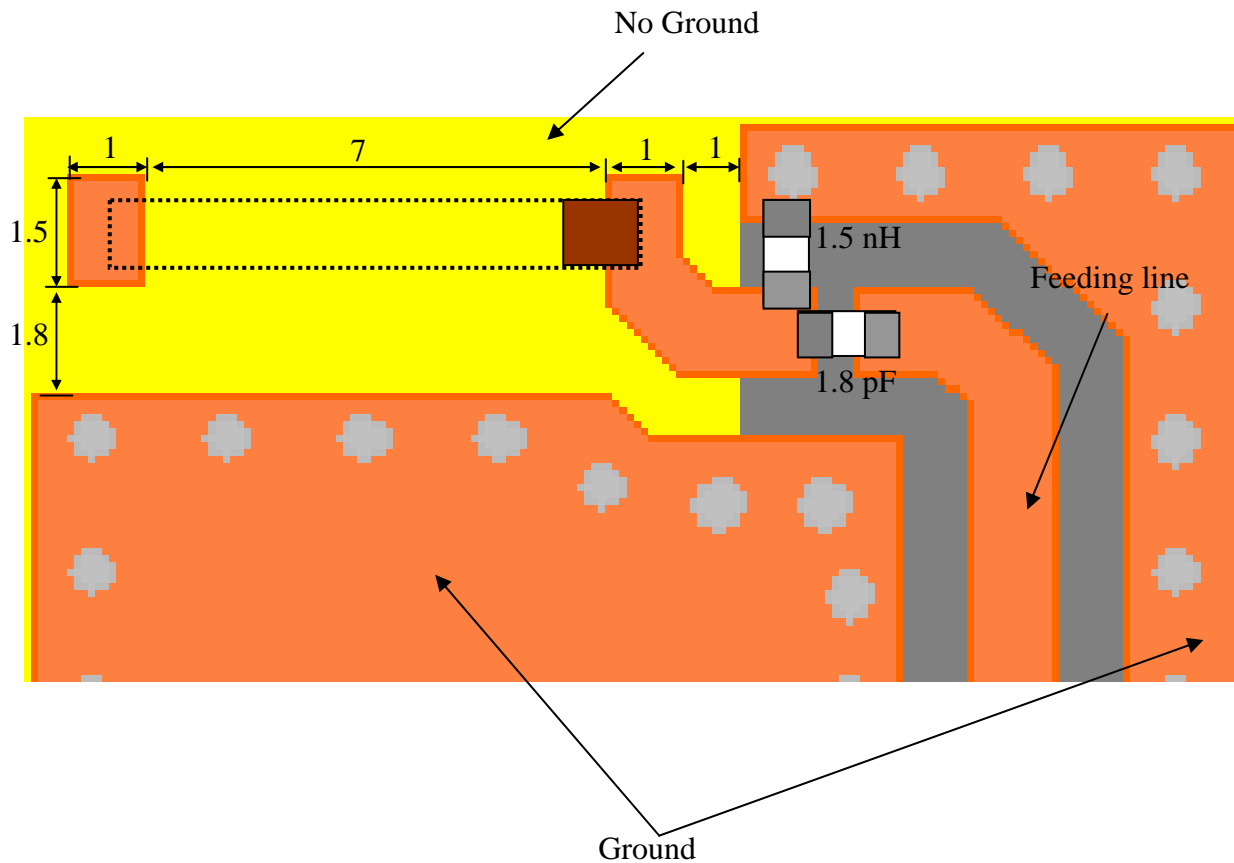

(Matching circuit and component values will be different, depending on PCB layout)

*Line width should be designed to match 50Ω characteristic impedance, depending on PCB material and thickness.

Typical Electrical Characteristics (T=25°C)

❖ Test Board – Type B (Unit in mm)

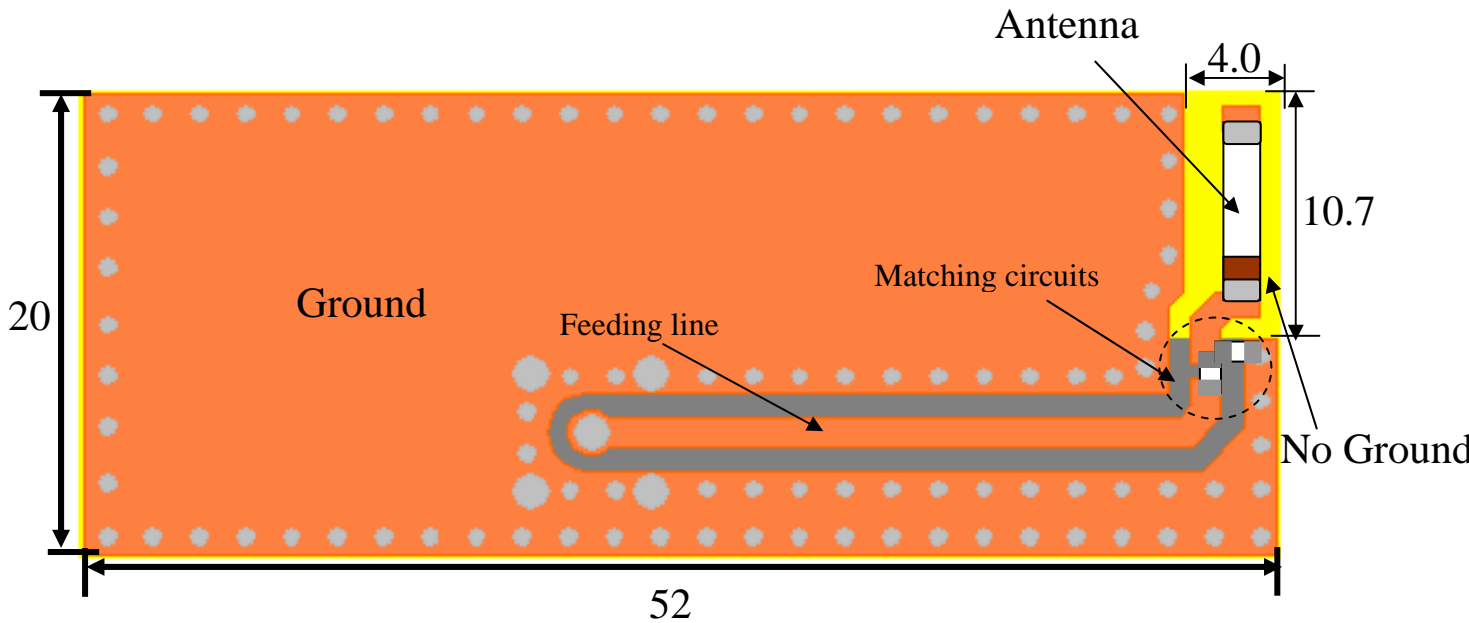

❖ Return Loss / With Matching Circuits

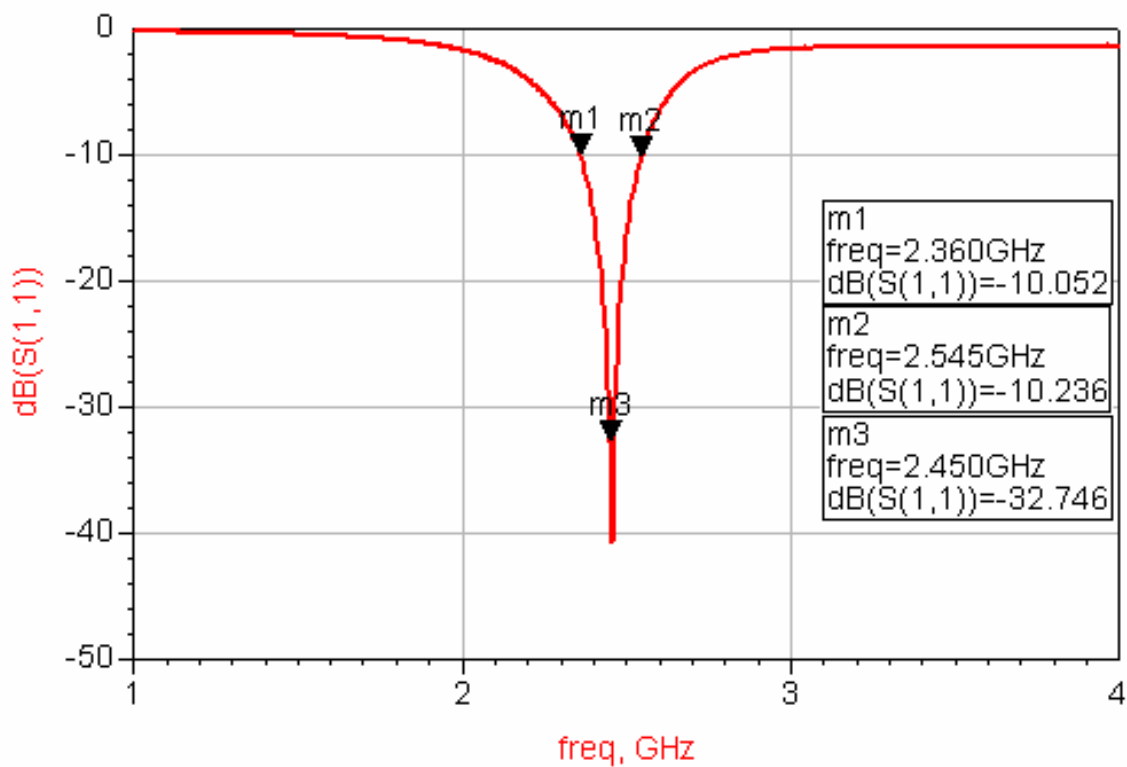

❖ Radiation Patterns

XY-V/XY-H

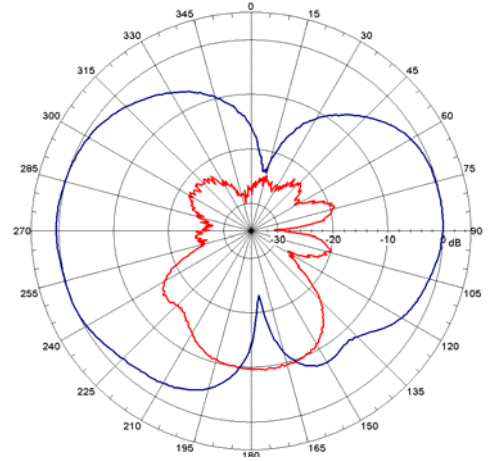
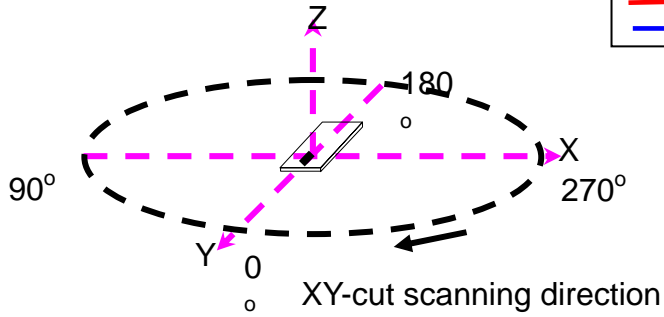

XZ-V/XZ-H

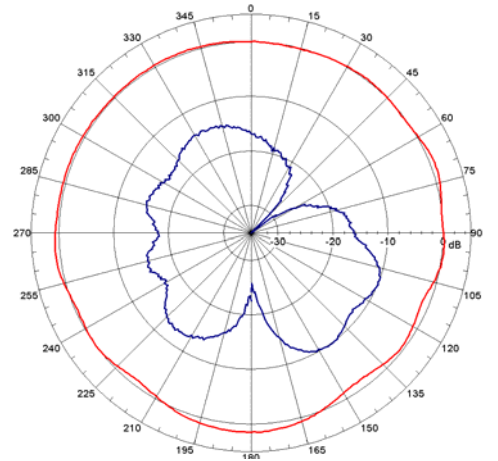
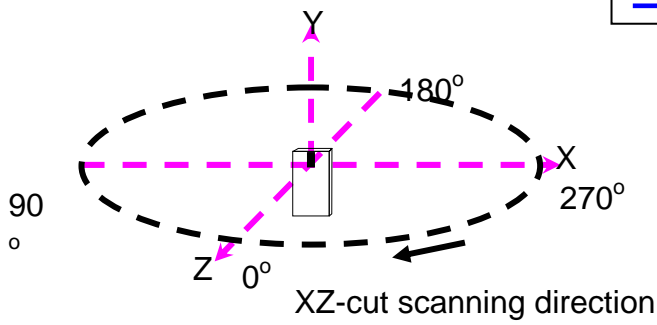

YZ-V/YZ-H

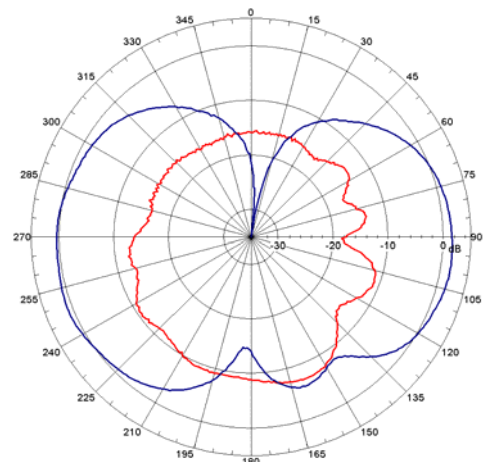
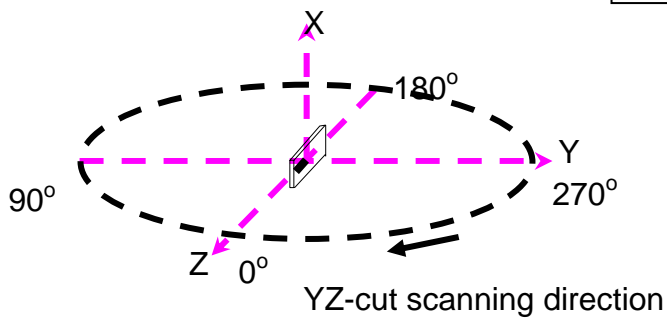

Advanced Ceramic X Corp.

16 Tzu Chiang Road, Hsinchu Industrial District Hsinchu Hsien 303, Taiwan

TEL:886-3-5987008 FAX:886-3-5987001

E-mail: acx@acxc.com.tw <http://www.acxc.com.tw>