	LCD MODULE SPECIFICATIONS	SPEC NO	
	YM240160C	REV NO	1.0

LCD Module

Specifications

Type: Standard

Model No. YM240160C

Description: 240x160 FSTN TAB Module,
with White LED B/L

Prepared: HCC

Checked: BOB JEN

Approved: JINGXI YANG

Issue Date: 4/11/2006

 **Dalian Good Display Co., Ltd.**

Tel: (86)-0411-84619565
Fax: (86)-0411-84619585
WebSite: <http://www.good-lcd.com>

CONTENTS

1.	FEATURES-----	1
2.	BLOCK DIAGRAM &APPLICATION CIRCUIT -----	1
3.	OUTLINE DIMENSIONS-----	2
4.	ABSOLUTE MAXIMUM RATING -----	3
5.	ELECTRICAL CHARACTERISTICS -----	3
6.	OPTICAL CHARACTERISTICS-----	4
7.	TIMING CHARACTERISTICS -----	5, 6
8.	Display Control Instruction -----	7, 8, 9
9.	INTERFACE PIN CONNECTIONS-----	10
10.	RELIABILITY -----	11
11.	QUALITY GUARANTEE -----	11
12.	INSPECTION CRITERIA -----	12-16
13.	PRECAUTIONS FOR USING LCD MODULES -----	16, 17
14.	USING LCD MODULES	17-20

1. FEATURES :

ITEM	STANDARD VALUE	UNIT
Display Type	240×160 dots	-
LCD Type	FSTN , Transflective ,Positive	-
LCD Duty	1/160	-
Viewing Direction	12:00 o'clock	
Backlight Type	White edge LED	-
Interface	6800/8080 SERIES MPU	-
Controller/Driver	UC1611 (TAB IC)	-
LCD Bias	1/12	-
Module Dimension	75.6(W)×55.1(H)×7.0(T)	mm
Viewing Area	62.0(W)×45.7(H)	mm
Dot Size	0.21(W)×0.24 (H)	mm
Dot Pitch	0.23(W)×0.26 (H)	mm

2. BLOCK DIAGRAM & APPLICATION CIRCUIT :

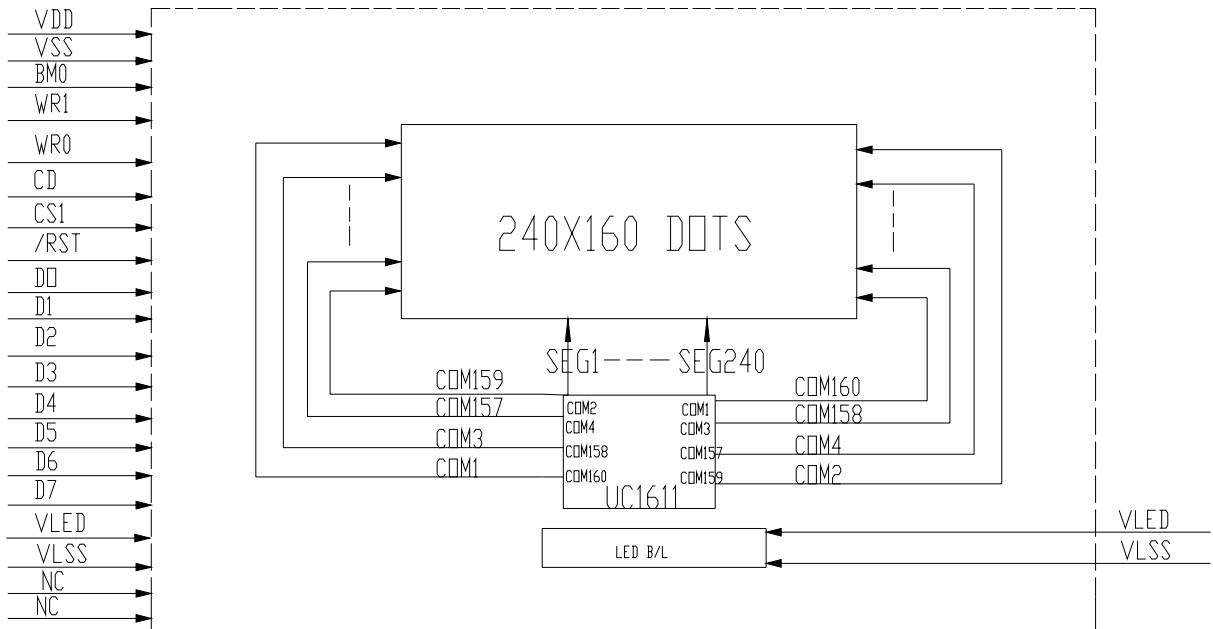

3. OUTLINE DIMENSIONS

- NOTES:
1. DISPLAY TYPE: FSTN,
 2. VIEWING DIRECTION: 6 O'CLOCK
 3. POLARIZER MODE: TRANSPARENT
 4. OPERATING TEMP: -20°C~+70°C
 5. STORAGE TEMP: -30°C~+80°C
 6. VDD: +3.0V
 7. DRIVE METHOD: 1/160 DUTY, 1/14 BIAS
 8. CONTROLLER: UC1611 (TAB :C)
 9. BACKLIGHT TYPE: WHITE LED (5.0V)
 10. DC/DC CONVERTER: BUILT-IN
 11. ALL UNMARKED TOLERANCES: ±0.5

VIEWING DIRECTION

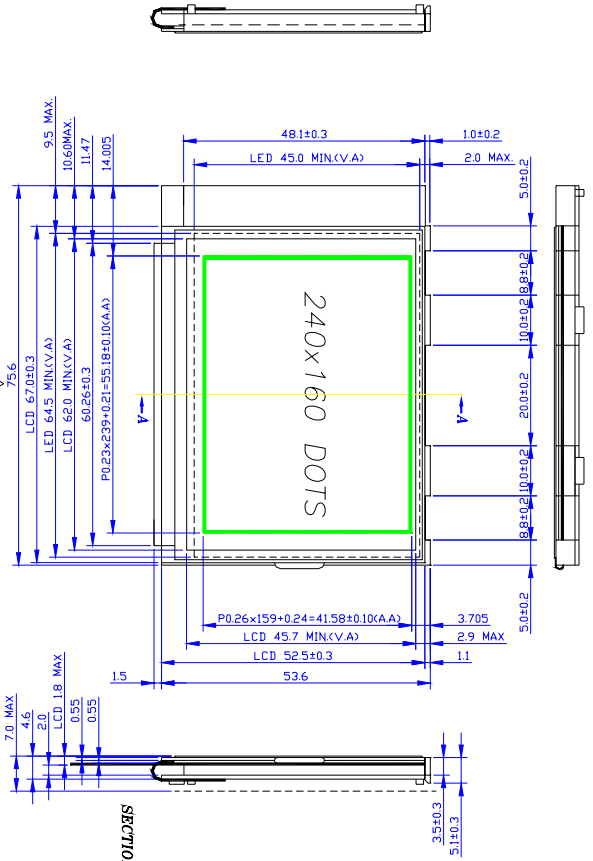

SECTION "A-A"

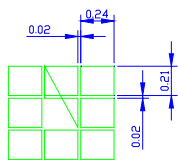
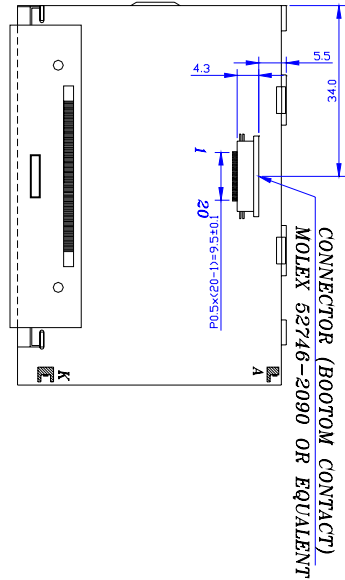

1	2	3	4	5	6	7	8	9	10
VDD	VSS	BMO	WR1	WR0	CD	CSI	/RST	DO	DI
11	12	13	14	15	16	17	18	19	20
D2	D3	D4	D5	D6	D7	VLED	VSSS	NC	NC

4. ABSOLUTE MAXIMUM RATING

ITEM	SYMBOL	CONDITION	STANDARD VALUE			UNIT
			MIN	TYP	MAX	
POWER SUPPLY FOR LOGIC	VDD-VSS	Ta=25°C	-0.3	3.0	4.0	V
INPUT VOLTAGE	VIN	Ta=25°C	-0.4	—	VDD+0.5	V
POWER SUPPLY FOR LCD DRIVING	VLCD		-0.3		18	V
Module OPERATION TEMPERATURE	TOPR	---	-20	—	+70	°C
Module STORAGE TEMPERATURE	TSTG	---	-30	—	+80	°C
Storage Humidity	H _D	Ta < 40 °C	-		90	%RH

5. ELECTRICAL CHARACTERISTICS

ITEM	SYMBOL	CONDITION	MIN	TYP	MAX	UNIT
Supply Voltage (logic)	VDD-VSS	-	1.8	3.0	3.3	V
Supply Voltage (LCD)	VDD-V0	Ta= -20 °C	-	-	-	V
		Ta= +25 °C	-	15.2	-	
		Ta= +70 °C	-	-	-	
Input signal voltage	V-IH	“H” level	0.8VDD	-	VDD	V
	V-IL	“L” level	VSS	-	0.2 VDD	V
Output signal voltage	V-OH	“H” level	0.8VDD	-	VDD	V
	VOL	“L” level	VSS	-	0.2VDD	V
Supply Current (logic)	IDD	VDD=3.0V	-	2.5	5	mA
Backlight Voltage	V-BL	VLED-VLSS	3.0	5.0	5.2	V
Backlight Current	I-BL		20 (vled=3v)	75	90	mA
Spectral width at half height				30		nm
Backlight Brightness	LV Sub.		230	250	280	cd/m ²
Backlight Life Time	HOUR			100000		h

6. OPTICAL CHARACTERISTICS

Item	Symbol	Condition	Min	Typ	Max	Unit	Remarks	Note
Response Time	Tr	-	-	110	220	ms	-	1
	Tf	-	-	260	520	ms	-	1
Contrast Ratio	Cr	-	-	3	-	-	-	2
Viewing Angle Range	θ	$Cr \geq 2$	-	-	30	deg	$\theta = 90$	3
			-	-	30	deg	$\theta = 270$	3
			15	-	105	deg	$\theta = 0$	3
			-	-	-	deg	$\theta = 180$	3

Note 1. Definition of response time

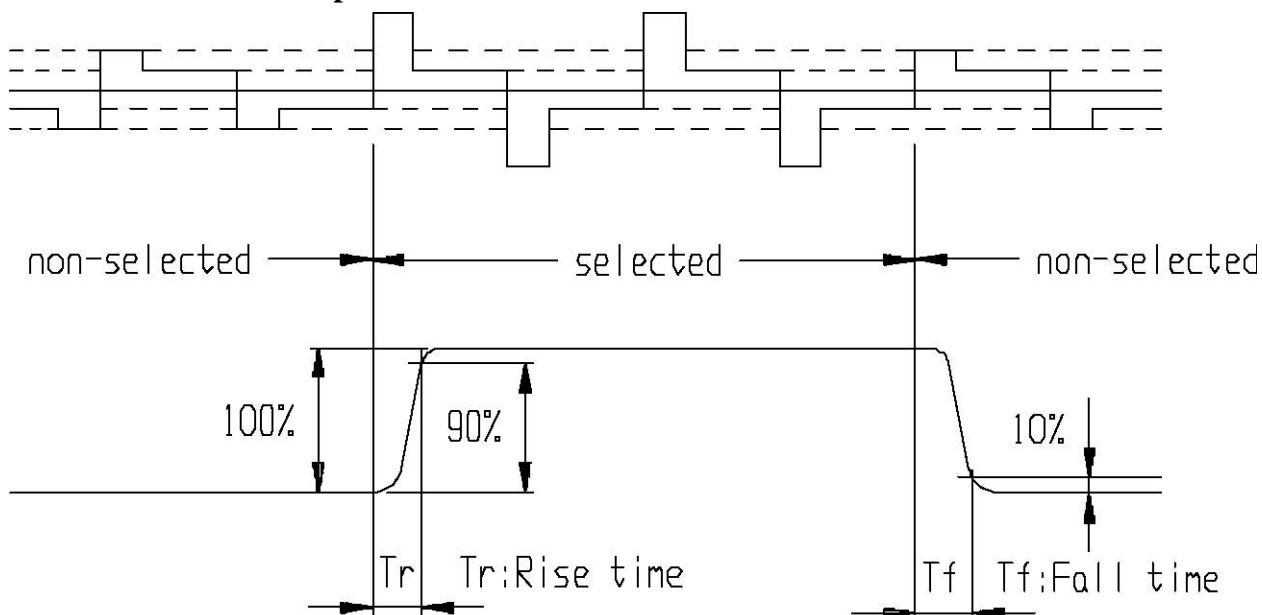

Note 2. Definition of Contrast Ratio 'Cr'

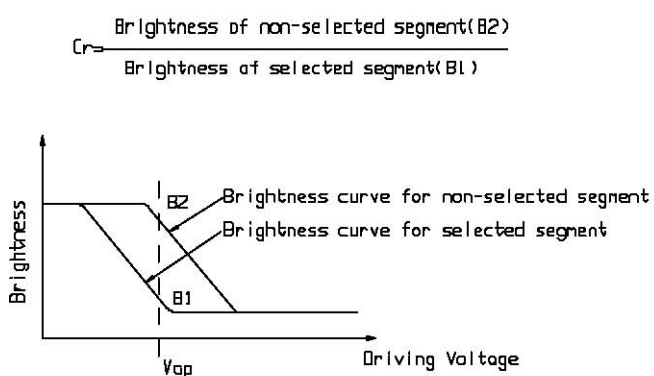

Note 3. Definition of Viewing Angle Range 'q'

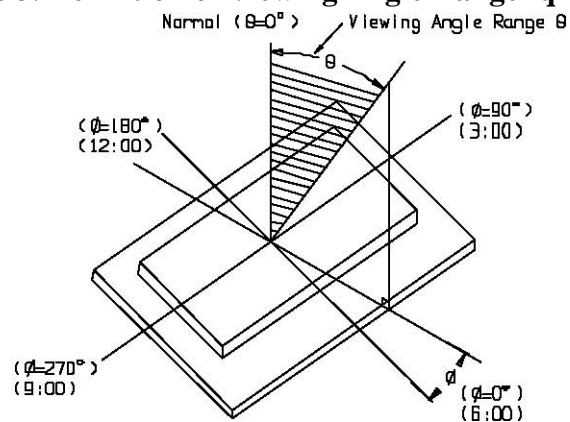

7. TIMING CHARACTERISTICS

AC Characteristics

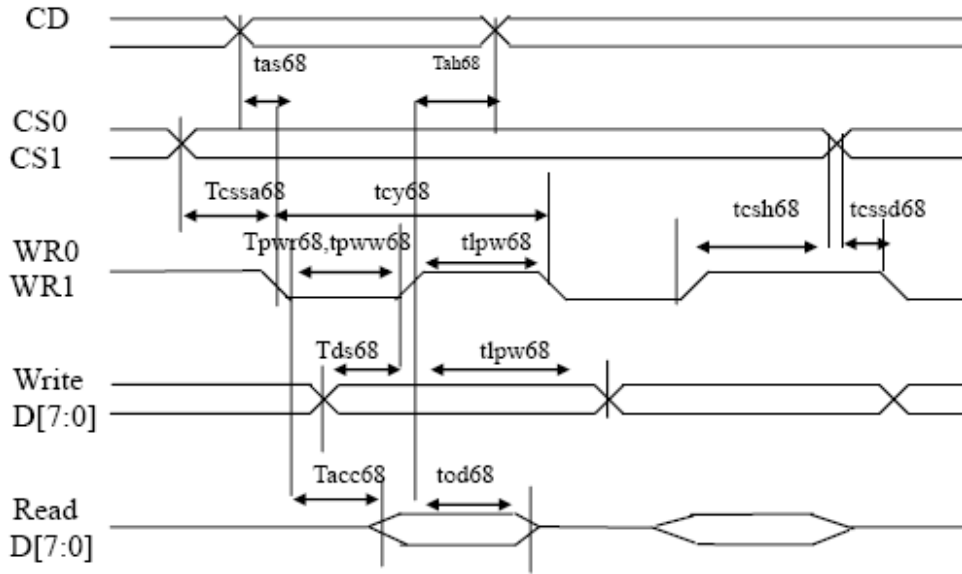

Parallel Bus Timing Characteristics (for 8080 MCU)

($2.5V \cong V_{DD} < 3.3V$, $T_a = -30$ to $85^\circ C$)

Symbol	Signal	Description	Condition	Min.	Max.	Units
t_{AS80} t_{AH80}	CD	Address setup time Address hold time		0 20	–	nS
t_{CY80}		System cycle time 8 bits bus (read) (write) 4 bits bus (read) (write)		140 80 140 80	–	nS
t_{PWR80}	WR1	Pulse width 8bits (read) 4bits		65 65	–	nS
t_{PWW80}	WR0	Pulse width 8bits (write) 4bits		35 35	–	nS
t_{HPW80}	WR0,WR1	High pulse width 8 bits bus (read) (write) 4 bits bus (read) (write)		65 35 65 35	–	nS
t_{DS80} t_{DH80}	D0~D7	Data setup time Data hold time		30 15	–	nS
t_{ACC80} t_{OD80}		Read access time Output disable time	$C_L=100pF$	– 12	60 20	nS
t_{SSA80} t_{CSSD80} t_{CSH80}	CS1/CS0	Chip select setup time		10 20 10		nS

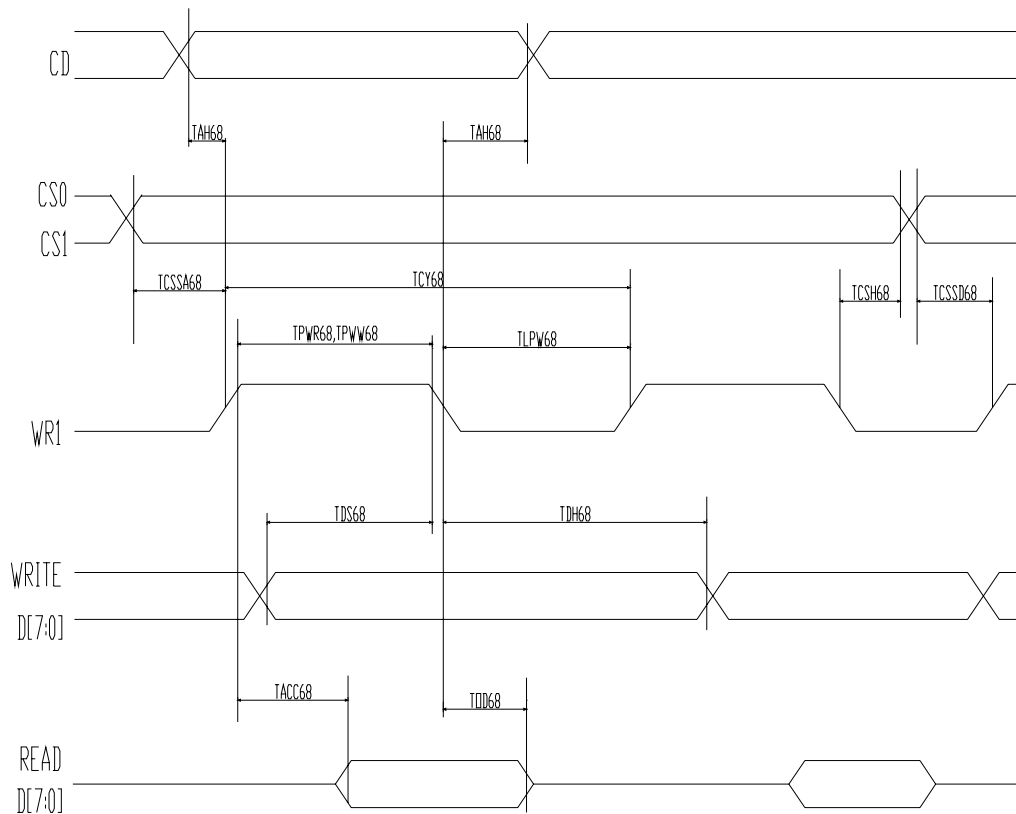

Parallel Bus Timing Characteristics (for 6800 MCU)

($2.5V \leq V_{DD} < 3.3V$, $T_a = -30$ to $85^\circ C$)

Symbol	Signal	Description	Condition	Min.	Max.	Units
t_{AS68}	CD	Address setup time		0	–	nS
t_{AH68}		Address hold time		20	–	nS
t_{CY68}		System cycle time		140		nS
		8 bits bus (read)		80		
		(write)		140	–	
		4 bits bus (read)		80		
t_{PWR68}	WR1	Pulse width 8bits (read)		65	–	nS
t_{PW68}		4bits		65	–	nS
t_{HPW68}		Pulse width 8bits (write)		35	–	nS
		4bits		35	–	
		High pulse width		65		
		8 bits bus (read)		35	–	
t_{DS68}	D0~D7	Data setup time		30	–	nS
t_{DH68}		Data hold time		15	–	
t_{ACC68}		Read access time	$C_L = 100pF$	–	60	nS
t_{OD68}		Output disable time		12	20	
t_{SSA68}	CS1/CS0	Chip select setup time		10		nS
t_{CSSD68}				20		
t_{CSH68}				10		

8. Display Control Instruction

The internal LSI contains registers that control the chip operation. These registers can be modified by commands. The following table is a summary of the control registers, their meaning and their default value. Commands supported by the chip will be described in the next section.

Name: The symbolic reference of the register.

Note that, some symbol names refer to bits (flags) within another register.

Default: Numbers shown in **Bold** font are default values after Power-Up-Reset and System-Reset.

Name	Bits	Default	Description
SL	8	0H	Scroll Line. Scroll the displayed image up by SL rows. The valid SL value are between 0 (for no scrolling) and (159-FL). Setting SL outside of this range causes undefined effect on the displayed image.
FL	4	0H	Fixed lines. The first (FLx2) lines of each frame are fixed and are not affected by scrolling (SL). When FL is non-zero, the screen is effectively separated into two regions: one scrollable, one non-scrollable.
CR	8	0H	Return Column Address. Useful for cursor implementation.
CA	8	0H	Display Data RAM Column Address (Used in Host to Display Data RAM access)
PA	7	0H	Display Data RAM Column Address (Used in Host to Display Data RAM access)
BR	2	2H	Bias Ratio. The ratio between V_{LCD} and V_{BIAS} . 00b:5 01b:10 10b:11 11b:12
TC	2	0H	Temperature compensation (per °C). 00b:-0.05% 01b:-0.10% 10b:-0.15% 11b:-0.20%
GN	2	3H	Gain, coarse setting of V_{BIAS} and V_{LCD}
PM	6	10H	Electronic Potentiometer to fine tune V_{BIAS} and V_{LCD}
OM	2	-	Operating Modes (Read Only) 00b: Reset 01b: (Not used) 10b: Sleep 11b: Normal
BZ	1	-	Busy with internal processes (reset, changing mode, etc.) OK for Display RAM read/write access.
RS	1	-	Reset in progress, Host Interface not ready
PC	4	DH	Pump Control and LCD panel loading. PC[1:0]: Panel Loading 00b:LCD:<20nF 01b:LCD:20~28nF 10b:LCD:28~40nF 11b:LCD:40~56nF PC[3:2]:Pump Control 00b:External V_{LCD} 01b:Internal V_{LCD} (Low V_{LCD} , only use when BR=5) 11b:Internal V_{LCD} (Standard)
APC0	8	FDH	Advanced Product Configuration. For ultraChip only. Please do not use.

Name	Bits	Default	Description
DC	5	0H	<p>Display Control:</p> <p>DC[0]:PXV: Pixels Inverse. Bit-wise data inversion. (default 0: OFF)</p> <p>DC[1]:APO: All Pixels ON(Default 0: OFF)</p> <p>DC[4:2]: Display ON/OFF (Default 000)</p> <p>Each bit controls a set of SEG (column) drives(80-80-80).</p> <p>When DC[4:2] is set to "HLH",The chip is turned into a 160*160 controller-driver and the programmers' view of CA becomes 0~159. Setting DC[4:2] flag does not affect the content of display RAM.</p>
AC	4	1H	<p>Address Control:</p> <p>AC[0]: WA: Automatic column/page Wrap Around (Default 1: ON)</p> <p>AC[1]: Auto-Increment order 0: Column (CA) first 1: Page (PA) first</p> <p>AC[2]: PID:PA (page address) auto increment direction (0:+1 1:-1)</p> <p>AC[3]: CUM:Cursor update mode, (Default: 0: OFF)</p> <p>When CUM=1, CA increment on write only, wrap around suspended</p>
MC	8	EFH	<p>Max. CA. CA wrapping boundary: when CA+1=MC ,CA will be reset to 0.The proper value range for MC is undefined when MC is out of these ranges.</p>
CEN	8	9FH	COM scanning end (last COM with full line cycle, 0 based index).
DST	8	00H	Display start (frist COM with active scan pulse, 0 based index)
DEN	8	9FH	Display end (last COM with active scan pulse, 0 based index)
			<p>Please maintain the following relationship: CEN= the actual number of pixel rows on the LCD-1 $CEN \geq DEN \geq DST+9$</p>
LC	10	0D0H	<p>LCD Control:</p> <p>LC[0]:MSF: MSB First mapping Option (Default:: OFF)</p> <p>LC[1]:MX, Mirror X. SEG/Column sequence inversion (Default: OFF)</p> <p>LC[2]:MY, Mirror Y. COM/Row sequence inversion (Default:: OFF)</p> <p>LC[4:3]: Line Rate (Klps: Kilo-Line-per-second) 00b: 20klps 01b: 24 klps 10b: 28klps 11b: 32 klps (Frane-Rate=Line-Rate/Mux-Rate)</p> <p>LC[6:5]: Gray Scale selection 00b: black/white 01b: 8 gray scale 10b: 16 gray scale 11b:64 gray scale</p> <p>LC[7] : Reserved (Default:: 1b)</p> <p>LC[9:8] : Partial Display Control 0xb: Disable Mux-rate =CEN+1 DST, DEN not used. 10b: Enable Mux-rate = DEN-DST=1 11b: Enabled Mux-rate =DEN-DST+1</p>

COMMAND TABLE

The following list of host commands is supported by LSI

C/D: 0: Control 1: Data
W/R: 0: Write cycle 1: Read cycle
Effective Data bits
- Don't Care

command	C/D	W/R	D7	D6	D5	D4	D3	D2	D1	D0	Action	Default
1 Write Data Byte	1	0	#	#	#	#	#	#	#	#	Write 1 byte	N/A
2 Read Data Byte	1	1	#	#	#	#	#	#	#	#	Read 1 byte	N/A
3 Get Status	0	1	BZ	MX	MY	RS	WA	DE	PM[7:6]		Get Status	N/A
4 Set Column Addr. LSB	0	0	0	0	0	0	#	#	#	#	Set CA[3:0]	0
4 Set Column Addr. MSB	0	0	0	0	0	1	#	#	#	#	Set CA[7:4]	0
5 Temp. Compensation.	0	0	0	0	1	0	0	1	#	#	Set TC [1:0]	00b:-0.05%/°C
6 Ste Panel Loading	0	0	0	0	1	0	1	1	#	#	Set PC[1:0]	01B:20-28nF
7 Ste Pump Control	0	0	0	0	1	0	1	1	#	#	Set PC[3:2]	11b
8 Set Adv. Control (double byte command)	0	0	0	0	1	1	0	0	0	R	Set APC[R][7:0] Where R=0 or 1	N/A
9 Ste Max CA (double byte command)	0	0	0	1	0	0	#	#	#	#	Set MC	239
10 Set Scroll Line LSB	0	0	0	1	0	0	#	#	#	#	Set SL[3:0]	0
10 Ste Scroll Line MSB	0	0	0	1	0	1	#	#	#	#	Set SL[7:4]	0
11 Ste Page Address LSB	0	0	0	1	1	0	#	#	#	#	Set Pva[3:0]	0
11 Set Page Address MSB	0	0	0	1	1	1	#	#	#	#	Set PA[7:4]	0
12 Set Gain and Potentiometer (double byte command)	0	0	1	0	0	0	0	0	0	1	Set {GN[1:0],Pm[5:0]}	PM=16 GN=11B
13 Set Partial Display Control	0	0	1	0	0	0	0	1	#	#	Set LC[9:8]	0: Disable
14 Set RAM Address Control	0	0	1	0	0	0	1	#	#	#	Set AC[2:0]	001b
15 Set Fixed Lines	0	0	1	0	0	1	#	#	#	#	Set FL[3:0]	0
16 Set Line Rate	0	0	1	0	1	0	0	0	#	#	Set LC94:3)	10b
17 Set All-Pixel-ON	0	0	1	0	1	0	0	1	0	#	Set DC[1]	0
18 Set Inverse Display	0	0	1	0	1	0	0	1	1	#	Set DC[0]	0
19 Set Display Enable	0	0	1	0	1	0	1	#	#	#	Set DC[4:2]	0
20 Set LCD Mapping Control	0	0	1	1	0	0	0	#	#	#	Set LC[2:0]	0
21 Set Gray Scale Mode	0	0	1	1	0	1	0	0	#	#	Set LC[6:5]	10b=16 shade
22 System Reset	0	0	1	1	1	0	0	0	1	0	System Reset	N/A
23 NOP	0	0	1	1	1	0	0	0	1	1	No operation	N/A
24 Set test control (double-byte command)	0	0	1	1	1	0	0	1	TT		For testing only	N/A
	0	0	#	#	#	#	#	#	#	#	Do not use.	N/A
25 Set LCD Bias Ratio	0	0	1	1	1	0	1	0	#	#	Set BR[1:0]	10b: 11
26 Reset cursor update Mode	0	0	1	1	1	0	1	1	1	0	AC[3]=0, CA=CR	N/A
27 Set Cursor Update Mode	0	0	1	1	1	0	1	1	1	1	AC[3]=1, CR=CA	N/A
28 Set COM End	0	0	1	1	1	1	0	0	0	1	Set CEN[7:0]	159
	0	0	#	#	#	#	#	#	#	#		
29 Set Partial Display Start	0	0	1	1	1	1	0	0	1	0	Set DST[7:0]	0
	0	0	#	#	#	#	#	#	#	#		
30 Set Partial Display Endt	0	0	1	1	1	1	0	0	1	1	Set DEN[7:0]	159
	0	0	#	#	#	#	#	#	#	#		

9.INTERFACE PIN CONNECTIONS

PIN	SYMBOL	TYPE	FUNCTION		
1	VDD	PWR	POWER SUPPLY FOR LOGIC		
2	VSS	GND	Ground		
3	BM0	I	“L” : 8080 SERIES MPU “H” : 6800 SERIES MPU		
4	WR1	I	SERIES MPU TYPE	WR0	WR1
			8080 SERIES MPU	/WR	/RD
5	WR0	I	6800 SERIES MPU	R/W	E
6	CD	I	Register select input pin - CD = "H": DB0 to DB7 are display data - CD = "L": DB0 to DB7 are control data		
7	CS1	I	CHIP ENBLE INPUTS, CS1= “H” : ENABLE ; CS1= “L” : DISABLE		
8	/RST	I	HARDWARE RESET INPUT		
9	DB0	I/O	DATA BUS		
10	DB1	I/O			
11	DB2	I/O			
12	DB3	I/O			
13	DB4	I/O			
14	DB5	I/O			
15	DB6	I/O			
16	DB7	I/O			
17	VLED	I	LED BACKLEGHT DRIVER VOLTAGE (+)		
18	VLSS	I	LED BACKLEGHT DRIVER VOLTAGE (-)		
19	NC		NO CONNECTION		
20	NC		NO CONNECTION		

10.RELIABILITY

Content of Reliability Test

Environmental Test				
No.	Test Item	Content of Test	Test Condition	Applicable Standard
1	High temperature storage	Endurance test applying the high storage temperature for a long time.	80 °C 200 hrs	
2	Low temperature storage	Endurance test applying the low storage temperature for a long time.	-30 °C 200 hrs	
3	High temperature operation	Endurance test applying the electric stress (Voltage & Current) and the thermal stress to the element for a long time.	70 °C 200 hrs	
4	Low temperature operation	Endurance test applying the electric stress under low temperature for a long time.	-20 °C 200 hrs	
5	High temperature Humidity storage	Endurance test applying the high temperature and high humidity storage for a long time.	50 °C , 90 RH 96 hrs	MIL-202E-103B JIS-C5023
6	High temperature Humidity operation	Endurance test applying the electric stress (Voltage & Current) and temperature humidity stress to the element for a long time.	50 °C , 90 RH 96 hrs	MIL-202E-103B JIS-C5023
7	Temperature cycle	Endurance test applying the low and high temperature cycle. $\begin{array}{c} -20^{\circ}\text{C} \quad \rightleftharpoons \quad 25^{\circ}\text{C} \quad \rightleftharpoons \quad 70^{\circ}\text{C} \\ 30\text{min.} \quad \leftarrow \quad 5\text{min.} \quad \rightarrow \quad 30\text{min.} \\ \longleftarrow \hspace{10em} \longrightarrow \\ \text{1 cycle} \end{array}$	-20°C – 70°C 10 cycles	
Mechanical Test				
8	Vibration test	Endurance test applying the vibration during transportation and using.	10-22Hz → 1.5mmp-p 22-500Hz → 1.5G Total 0.5hrs	MIL-202E-201A JIS-C5025 JIS-C7022-A-10
9	Shock test	Constructional and mechanical endurance test applying the shock during transportation.	50G half sign wave 1l msdc 3 times of each direction	MIL-202E-213B
10	Atmospheric pressure test	Endurance test applying the atmospheric pressure during transportation by air.	115 mbar 40 hrs	MIL-202E-105C
Others				
11	Static electricity test	Endurance test applying the electric stress to the terminal.	VS=800V, RS=1.5 k CS=100 pF 1 time	MIL-883B-3015.1

*** Supply voltage for logic system = 3V. Supply voltage for LCD system = Operating voltage at 25°C.

Failure Judgement Criterion

Criterion Item	Test Item No.											Failure Judgment Criterion
	1	2	3	4	5	6	7	8	9	10	11	
Basic specification												Out of the Basic Specification
Electrical characteristic												Out of the DC and AC Characterstic
Mechanical characteristic												Out of the Mechanical Specification Color change : Out of Limit Apperance Specification
Optical characteristic												Out of the Apperance Standard

11. QUALITY GUARANTEE

Acceptable Quality Level

Each lot should satisfy the quality level defined as follows.

- Inspection method : MIL-STD-105E LEVEL II Normal one time sampling
- AQL

Partition	AQL	Definition
A: Major	0.4%	Functional defective as product
B: Minor	1.5%	Satisfy all functions as product but not satisfy cosmetic standard

Definition of 'LOT'

One lot means the delivery quantity to customer at one time.

Conditions of Cosmetic Inspection

Environmental condition

The inspection should be performed at the 1cm of height from the LCD module under 2 pieces of 40W white fluorescent lamps (Normal temperature 20~25°C and normal humidity 60 ± 15%RH).

Inspection method



The visual check should be performed vertically at more than 30cm distance from the LCD panel.

Driving voltage

The VO value which the most optimal contrast can be obtained near the specified VO in the specification. (Within ± 0.5V of typical value at 25°C.).

12. INSPECTION CRITERIA

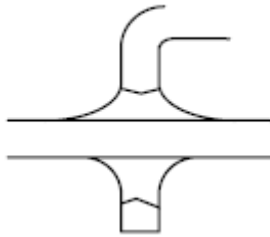
12.1 Module Cosmetic Criteria

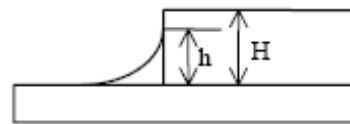
No.	Item	Judgement Criterion	Partition
1	Difference in Spec.	None allowed	Major
2	Pattern peeling	No substrate pattern peeling and floating	Major
3	Soldering defects	No soldering missing No soldering bridge No cold soldering	Major Major Major
4	Resist flaw on substrate	Invisible copper foil ('0.5mm or more) on substrate pattern	Minor
5	Accretion of metallic Foreign matter	No soldering dust No accretion of metallic foreign matters (Not exceed '0.2mm)	Minor Minor
6	Stain	No stain to spoil cosmetic badly	Minor
7	Plate discoloring	No plate fading, rusting and discoloring	Minor
8	Solder amount	<p>a. Soldering side of PCB Solder to form a 'Filet' all around the lead. Solder should not hide the lead form perfectly. (too much)</p> <p>b. Components side (In case of 'Through Hole PCB')</p> <p>Solder to reach the Components side of PCB.</p>	Minor
	1. Lead parts		
	2. Flat packages	<p>Either 'Toe' (A) or 'Seal' (B) of the lead to be covered by 'Filet'.</p> <p>Lead form to be assume over solder. A B</p> 	Minor
	3. Chips	$(3/2) H \geq h \geq (1/2) H$ 	Minor

12.2 Screen Cosmetic Criteria (Non-Operating)

No.	Defect	Judgement Criterion	Partition										
1	Spots	In accordance with <i>Screen Cosmetic Criteria (Operating) No.1.</i>	Minor										
2	Lines	In accordance with <i>Screen Cosmetic Criteria (Operating) No.2.</i>	Minor										
3	Bubbles in polarizer	<table border="1"> <thead> <tr> <th>Size : d mm</th> <th>Acceptable Qty in active area</th> </tr> </thead> <tbody> <tr> <td>$d \leq 0.3$</td> <td>Disregard</td> </tr> <tr> <td>$0.3 < d \leq 1.0$</td> <td>3</td> </tr> <tr> <td>$1.0 < d \leq 1.5$</td> <td>1</td> </tr> <tr> <td>$1.5 < d$</td> <td>0</td> </tr> </tbody> </table>	Size : d mm	Acceptable Qty in active area	$d \leq 0.3$	Disregard	$0.3 < d \leq 1.0$	3	$1.0 < d \leq 1.5$	1	$1.5 < d$	0	Minor
Size : d mm	Acceptable Qty in active area												
$d \leq 0.3$	Disregard												
$0.3 < d \leq 1.0$	3												
$1.0 < d \leq 1.5$	1												
$1.5 < d$	0												
4	Scratch	In accordance with spots and lines operating cosmetic criteria. When the light reflects on the panel surface, the scratches are not to be remarkable.	Minor										
5	Allowable density	Above defects should be separated more than 30mm each other.	Minor										
6	Coloration	Not to be noticeable coloration in the viewing area of the LCD panels. Back-lit type should be judged with back-lit on state only.	Minor										
7	Contamination	Not to be noticeable.	Minor										

12.3. Screen Cosmetic Criteria (Operating)

No.	Defect	Judgement Criterion	Partition																				
1	Spots	<p>A) Clear Note :</p> <table border="1"> <thead> <tr> <th>Size : d mm</th> <th>Acceptable Qty in active area</th> </tr> </thead> <tbody> <tr> <td>$d \leq 0.1$</td> <td>Disregard</td> </tr> <tr> <td>$0.1 < d \leq 0.2$</td> <td>3</td> </tr> <tr> <td>$0.2 < d \leq 0.3$</td> <td>2</td> </tr> <tr> <td>$0.3 < d$</td> <td>0</td> </tr> </tbody> </table> <p>Including pin holes and defective dots which must be within one pixel size.</p> <p>B) Unclear Size :</p> <table border="1"> <thead> <tr> <th>Size : d mm</th> <th>Acceptable Qty in active area</th> </tr> </thead> <tbody> <tr> <td>$d \leq 0.2$</td> <td>Disregard</td> </tr> <tr> <td>$0.2 < d \leq 0.5$</td> <td>6</td> </tr> <tr> <td>$0.5 < d \leq 0.7$</td> <td>2</td> </tr> <tr> <td>$0.7 < d$</td> <td>0</td> </tr> </tbody> </table>	Size : d mm	Acceptable Qty in active area	$d \leq 0.1$	Disregard	$0.1 < d \leq 0.2$	3	$0.2 < d \leq 0.3$	2	$0.3 < d$	0	Size : d mm	Acceptable Qty in active area	$d \leq 0.2$	Disregard	$0.2 < d \leq 0.5$	6	$0.5 < d \leq 0.7$	2	$0.7 < d$	0	Minor
Size : d mm	Acceptable Qty in active area																						
$d \leq 0.1$	Disregard																						
$0.1 < d \leq 0.2$	3																						
$0.2 < d \leq 0.3$	2																						
$0.3 < d$	0																						
Size : d mm	Acceptable Qty in active area																						
$d \leq 0.2$	Disregard																						
$0.2 < d \leq 0.5$	6																						
$0.5 < d \leq 0.7$	2																						
$0.7 < d$	0																						

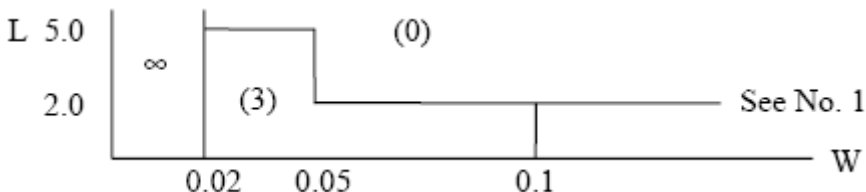
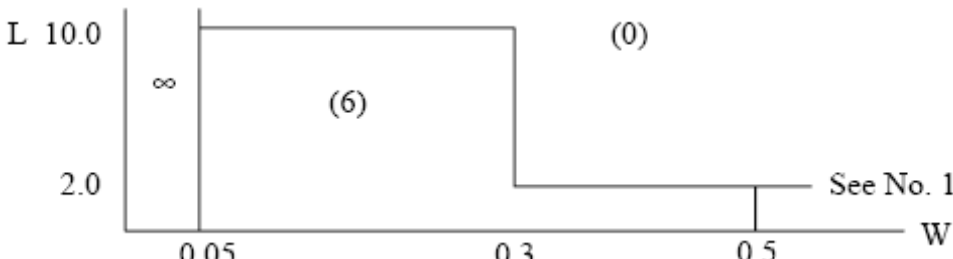
2	Lines	<p>A) Clear</p>  <p>Note : () - Acceptable Qty in active area L - Length (mm) W - Width (mm) ∞ - Disregard</p> <p>B) Unclear</p> 	Minor
---	-------	--	-------

'Clear' = The shade and size are not changed by VO.

'Unclear' = The shade and size are changed by VO.

12.4. Screen Cosmetic Criteria (Operating) (Continued)

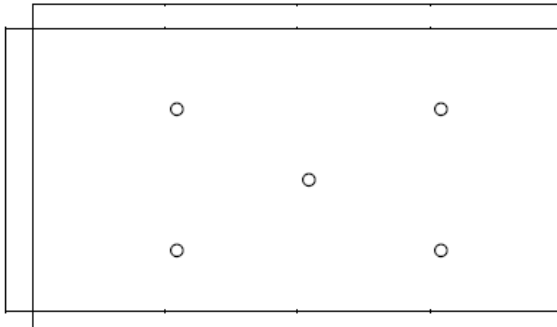
No.	Defect	Judgement Criterion	Partition
3	Rubbing line	Not to be noticeable.	
4	Allowable density	Above defects should be separated more than 10mm each other.	Minor
5	Rainbow	Not to be noticeable.	Minor
6	Dot size	To be 95% ~ 105% of the dot size (Typ.) in drawing. Partial defects of each dot (ex. pin-hole) should be treated as 'Spot'. (see <i>Screen Cosmetic Criteria (Operating) No.1</i>)	Minor
7	Uneven brightness (only back-lit type module)	<p>Uneven brightness must be $B_{MAX} / B_{MIN} \leq 2$</p> <ul style="list-style-type: none"> - BMAX : Max. value by measure in 5 points - BMIN : Min. value by measure in 5 points <p>Divide active area into 4 vertically and horizontally. Measure 5 points shown in the following figure.</p>  <p>○ : Measuring points</p>	Minor

Note :

(1) Size : $d = (\text{long length} + \text{short length}) / 2$

(2) The limit samples for each item have priority.

(3) Complexed defects are defined item by item, but if the number of defects are defined in above table, the total number should not exceed 10.

(4) In case of 'concentration', even the spots or the lines of 'disregarded' size should not allowed. Following three situations should be treated as 'concentration'.

- 7 or over defects in circle of '5mm.
- 10 or over defects in circle of '10mm.
- 20 or over defects in circle of '20mm.

13. PRECAUTIONS FOR USING LCD MODULES

Handing Precautions

(1) The display panel is made of glass. Do not subject it to a mechanical shock by dropping it or impact.

(2) If the display panel is damaged and the liquid crystal substance leaks out, be sure not to get any in your mouth. If the substance contacts your skin or clothes, wash it off using soap and water.

(3) Do not apply excessive force to the display surface or the adjoining areas since this may cause the color tone to vary.

(4) The polarizer covering the display surface of the LCD module is soft and easily scratched. Handle this polarizer carefully.

(5) If the display surface becomes contaminated, breathe on the surface and gently wipe it with a soft dry cloth. If it is heavily contaminated, moisten cloth with one of the following solvents :

- Isopropyl alcohol
- Ethyl alcohol

(6) Solvents other than those above-mentioned may damage the polarizer. Especially, do not use the following.

- Water
- Ketone
- Aromatic solvents

(7) Exercise care to minimize corrosion of the electrode. Corrosion of the electrodes is accelerated by water droplets, moisture condensation or a current flow in a high-humidity environment.

(8) Install the LCD Module by using the mounting holes. When mounting the LCD module make sure it is free of twisting, warping and distortion. In particular, do not forcibly pull or bend the IO cable or the backlight cable.

(9) Do not attempt to disassemble or process the LCD module.

(10) NC terminal should be open. Do not connect anything.

(11) If the logic circuit power is off, do not apply the input signals.

(12) To prevent destruction of the elements by static electricity, be careful to maintain an optimum work environment.

- Be sure to ground the body when handling the LCD modules.

-
- Tools required for assembling, such as soldering irons, must be properly grounded.
 - To reduce the amount of static electricity generated, do not conduct assembling and other work under dry conditions.

- The LCD module is coated with a film to protect the display surface. Exercise care when peeling off this protective film since static electricity may be generated.

Storage Precautions

When storing the LCD modules, avoid exposure to direct sunlight or to the light of fluorescent lamps. Keep the modules in bags (avoid high temperature, high humidity and low temperatures below 0°C). Whenever possible, the LCD modules should be stored in the same conditions in which they were shipped from our company.

Others

Liquid crystals solidify under low temperature (below the storage temperature range) leading to defective orientation or the generation of air bubbles (black or white). Air bubbles may also be generated if the module is subject to a low temperature.

If the LCD modules have been operating for a long time showing the same display patterns, the display patterns may remain on the screen as ghost images and a slight contrast irregularity may also appear. A normal operating status can be regained by suspending use for some time. It should be noted that this phenomenon does not adversely affect performance reliability.

To minimize the performance degradation of the LCD modules resulting from destruction caused by static electricity etc., exercise care to avoid holding the following sections when handling the modules.

- Exposed area of the printed circuit board.
- Terminal electrode sections.

14. USING LCD MODULES

Liquid Crystal Display Modules

LCD is composed of glass and polarizer. Pay attention to the following items when handling.

- (1) Please keep the temperature within specified range for use and storage. Polarization degradation, bubble generation or polarizer peel-off may occur with high temperature and high humidity.
- (2) Do not touch, push or rub the exposed polarizers with anything harder than an HB pencil lead (glass, tweezers, etc.).
- (3) N-hexane is recommended for cleaning the adhesives used to attach front/rear polarizers and reflectors made of organic substances which will be damaged by chemicals such as acetone, toluene, ethanol and isopropylalcohol.
- (4) When the display surface becomes dusty, wipe gently with absorbent cotton or other soft material like chamois soaked in petroleum benzine. Do not scrub hard to avoid damaging the display surface.
- (5) Wipe off saliva or water drops immediately, contact with water over a long period of time may cause deformation or color fading.
- (6) Avoid contacting oil and fats.
- (7) Condensation on the surface and contact with terminals due to cold will damage, stain or dirty the polarizers. After products are tested at low temperature they must be warmed up in a container before coming in contact with room temperature air.

(8) Do not put or attach anything on the display area to avoid leaving marks on.

(9) Do not touch the display with bare hands. This will stain the display area and degradate insulation between terminals (some cosmetics are determinated to the polarizers).

(10) As glass is fragile. It tends to become or chipped during handling especially on the edges. Please avoid dropping or jarring.

Installing LCD Modules

The hole in the printed circuit board is used to fix LCM as shown in the picture below. Attend to the following items when installing the LCM.

(1) Cover the surface with a transparent protective plate to protect the polarizer and LC cell.

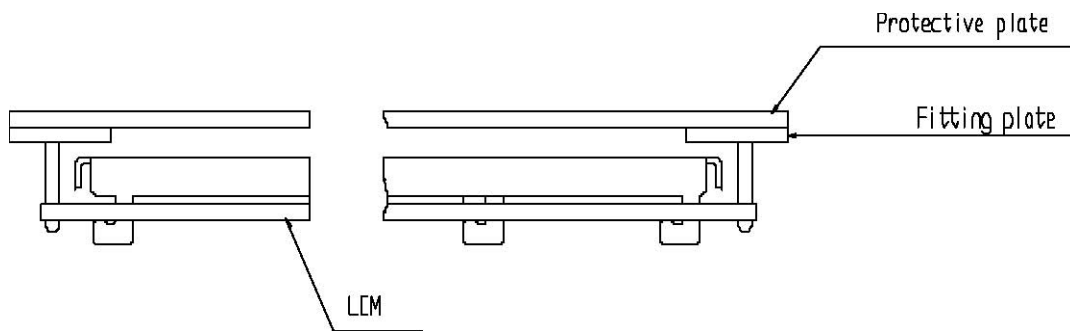

(2) When assembling the LCM into other equipment, the spacer to the bit between the LCM and the fitting plate should have enough height to avoid causing stress to the module surface, refer to the individual specifications for measurements. The measurement tolerance should be 0.1mm.

Precaution for Handling LCD Modules

Since LCM has been assembled and adjusted with a high degree of precision, avoid applying excessive shocks to the module or making any alterations or modifications to it.

(1) Do not alter, modify or change the the shape of the tab on the metal frame.

(2) Do not make extra holes on the printed circuit board, modify its shape or change the positions of components to be attached.

(3) Do not damage or modify the pattern writing on the printed circuit board.

(4) Absolutely do not modify the zebra rubber strip (conductive rubber) or heat seal connector.

(5) Except for soldering the interface, do not make any alterations or modifications with a soldering iron.

(6) Do not drop, bend or twist LCM.

Electro-Static Discharge Control

Since this module uses a CMOS LSI, the same careful attention should be paid to electrostatic discharge as for an ordinary CMOS IC.

(1) Make certain that you are grounded when handing LCM.

(2) Before remove LCM from its packing case or incorporating it into a set, be sure the module and your body have the same electric potential.

(3) When soldering the terminal of LCM, make certain the AC power source for the soldering iron does not leak.

(4) When using an electric screwdriver to attach LCM, the screwdriver should be of ground potentiality to minimize as much as possible any transmission of electromagnetic waves produced sparks coming from the

commutator of the motor.

(5) As far as possible make the electric potential of your work clothes and that of the work bench the ground potential.

(6) To reduce the generation of static electricity be careful that the air in the work is not too dried. A relative humidity of 50%~60% is recommended.

Precaution for soldering to the LCM

(1) Observe the following when soldering lead wire, connector cable and etc. to the LCM.

- Soldering iron temperature : 280°C ± 10°C.
- Soldering time : 3-4 sec.
- Solder : eutectic solder.

If soldering flux is used, be sure to remove any remaining flux after finishing to soldering operation. (This does not apply in the case of a non-halogen type of flux.) It is recommended that you protect the LCD surface with a cover during soldering to prevent any damage due to flux spatters.

(2) When soldering the electroluminescent panel and PC board, the panel and board should not be detached more than three times. This maximum number is determined by the temperature and time conditions mentioned above, though there may be some variance depending on the temperature of the soldering iron.

(3) When remove the electroluminescent panel from the PC board, be sure the solder has completely melted, the soldered pad on the PC board could be damaged.

Precautions for Operation

(1) Viewing angle varies with the change of liquid crystal driving voltage (VO). Adjust VO to show the best contrast.

(2) Driving the LCD in the voltage above the limit shortens its life.

(3) Response time is greatly delayed at temperature below the operating temperature range. However, this does not mean the LCD will be out of the order. It will recover when it returns to the specified temperature range.

(4) If the display area is pushed hard during operation, the display will become abnormal. However, it will return to normal if it is turned off and then back on.

(5) Condensation on terminals can cause an electrochemical reaction disrupting the terminal circuit. Therefore, it must be used under the relative condition of 40°C , 50% RH.

(6) When turning the power on, input each signal after the positive/negative voltage becomes stable.

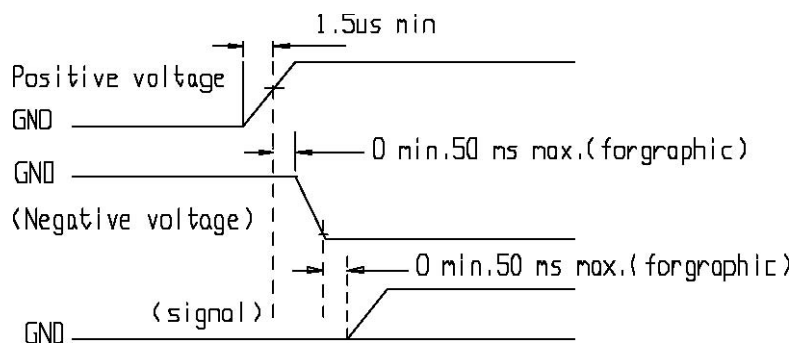

Storage

When storing LCDs as spares for some years, the following precaution are necessary.

(1) Store them in a sealed polyethylene bag. If properly sealed, there is no need for dessicant.

(2) Store them in a dark place. Do not expose to sunlight or fluorescent light, keep the temperature between 0°C and 35°C.

(3) The polarizer surface should not come in contact with any other objects. (We advise you to store them in the container in which they were shipped.)

Safety

(1) It is recommended to crush damaged or unnecessary LCDs into pieces and wash them off with solvents such as acetone and ethanol, which should later be burned.

(2) If any liquid leaks out of a damaged glass cell and comes in contact with the hands, wash off thoroughly with soap and water.

Limited Warranty

Unless agreed between GOOD DISPLAY and customer, GOOD DISPLAY will replace or repair any of its LCD modules which are found to be functionally defective when inspected in accordance with GOOD DISPLAY LCD acceptance standards (copies available upon request) for a period of one year from date of shipments. Cosmetic/visual defects must be returned to GOOD DISPLAY within 90 days of shipment. Confirmation of such date shall be based on freight documents. The warranty liability of GOOD DISPLAY limited to repair and/or replacement on the terms set forth above. GOOD DISPLAY will not be responsible for any subsequent or consequential events.

Return LCM under warranty

No warranty can be granted if the precautions stated above have been disregarded. The typical examples of violations are :

- Broken LCD glass.
- PCB eyelet's damaged or modified.
- PCB conductors damaged.
- Circuit modified in any way, including addition of components.
- PCB tampered with by grinding, engraving or painting varnish.
- soldering to or modifying the bezel in any manner.

Module repairs will be invoiced to the customer upon mutual agreement. Modules must be returned with sufficient description of the failures or defects. Any connectors or cable installed by the customer must be removed completely without damaging the PCB eyelet's, conductors and terminals.