

SG240128D (240 DOTS X 128 DOTS)

FEATURES

- ◆ RECOMMENDED CONTROLLER
(HD64646/MSM6225/SED1335)
- ◆ +5 V POWER SUPPLY
- ◆ 1/128 DUTY CYCLE
- ◆ EDGE LIGHTING TYPE LED BACKLIGHT
- ◆ EDGE LIGHTING TYPE CCFL BACKLIGHT

MECHANICAL DATA

ITEM	DIMENSIONS	UNIT
Module Size (W x H x T)	144.0 x 104.0 x 10.3 (15.1 LED)	mm
Viewing Area (W x H)	114.0 x 64.0	mm
Active Area (W x H)	107.95 x 57.55	mm
Dot Size (W x H)	0.40 x 0.40	mm
Dot Pitch (W x H)	0.45 x 0.45	mm

INTERFACE PIN CONNECTIONS

NO.	SYMBOL	LEVEL	FUNCTION
1	FLM	H	Frame Start Signal
2	M	H/L	Control Signal For AC Driving
3	LP	H→L	Common Driver Data Shift Signal
4	CP	H→L	Clock Pulse For Segment Shift Register
5	V _{DD}	5V	Power Supply Voltage
6	V _{SS}	0V	Power Supply Ground
7	V _{EE}	-	Power Supply Voltage For LCD
8	DB0	H/L	Data Bit0
9	DB1	H/L	Data Bit1
10	DB2	H/L	Data Bit2
11	DB3	H/L	Data Bit3
12	V _o	-	Contrast Adjustment Voltage
13	NC	-	No Connection

ABSOLUTE MAXIMUM RATINGS

ITEM	SYMBOL	MIN.	TYP.	MAX.	UNIT
Supply Voltage For Logic	V _{DD} -V _{SS}	0	-	7	V
Supply Voltage For LCD Drive	V _{DD} -V _o	0	-	28	V
Input Voltage	V _I	V _{SS}	-	V _{DD}	V

ELECTRICAL CHARACTERISTICS

ITEM	SYMBOL	CONDITION	MIN.	TYP.	MAX.	UNIT
Supply Voltage For Logic	V _{DD} -V _{SS}	-	4.5	5	5.5	V
LCD Supply Voltage	V _{DD} -V _o	V _{DD} =5V Ta=25°C	16.9	18	19.2	V
Supply Current	I _{DD}	V _{DD} =5V	-	15	24	mA
Input Voltage	"HIGH" Level	V _{IH}	-	2.2	-	V _{DD} V
	"LOW" Level	V _{IL}	-	-	0.6	V
Output Voltage	"HIGH" Level	V _{OH}	-	2.4	-	V
	"LOW" Level	V _{OL}	-	-	0.4	V

EXTERNAL DIMENSIONS

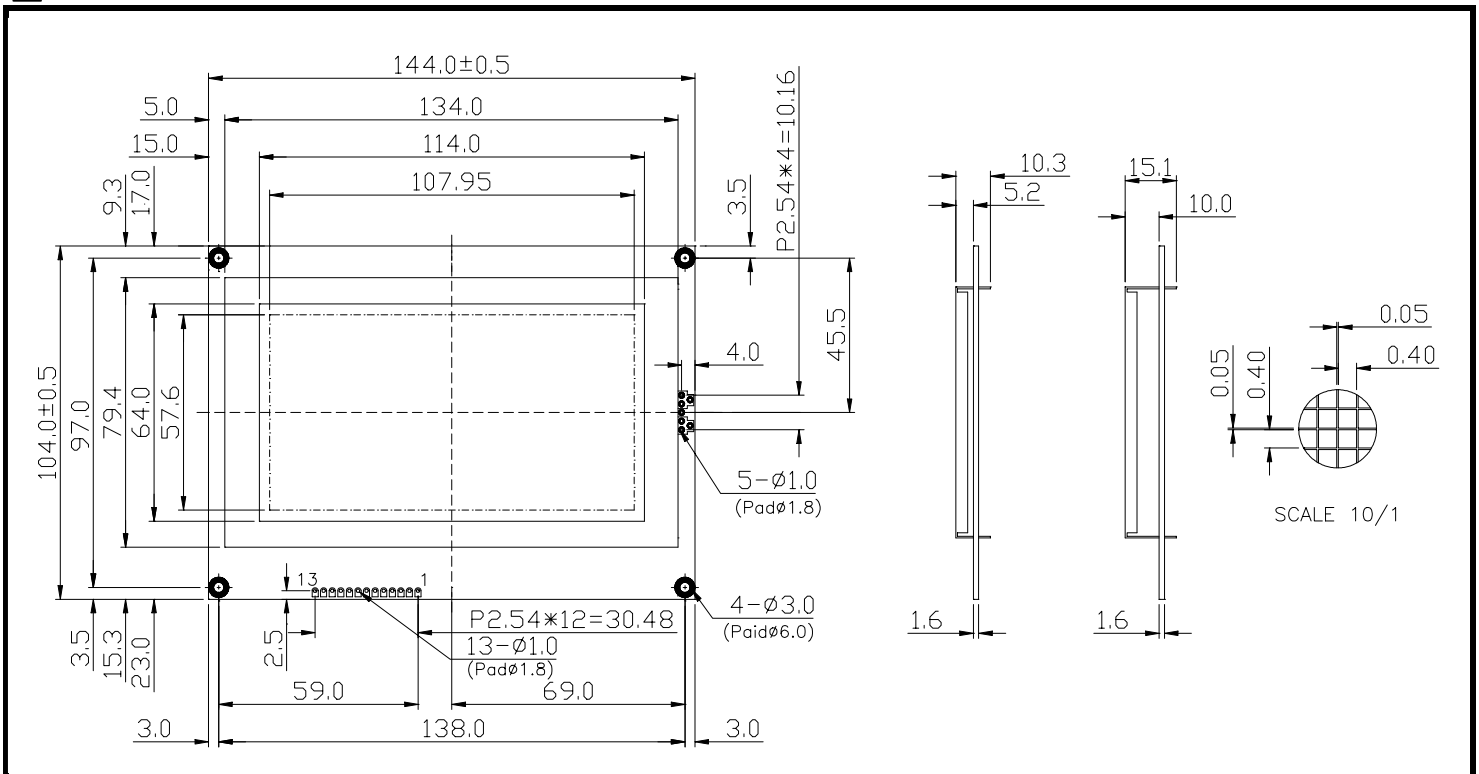

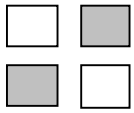

SG240128D (240 DOTS X 128 DOTS)

■ TIMING CHARACTERISTICS

ITEM	SYMBOL	MIN.	TYP.	MAX.	UNIT.
Frequency Of Maximum Clock	f_{CP}	-	-	8	MHZ
CL1, CL2, Pulse Width	t_w	45	-	-	ns
Rise, Fall Time	t_r, t_f	-	-	15	ns
Data Setup Time	t_{DSU}	20	-	-	ns
Data Hold Time	t_{DHD}	20	-	-	ns
CL1 Setup Time	t_{LSU}	80	-	-	ns
CL1→ CL2 Time	t_{LC}	80	-	-	ns
FLM Setup Time	t_{setup}	100	-	-	ns
FLM Hold Time	t_{hold}	100	-	-	ns
M Delay Time	t_{DF}	-	-	300	ns

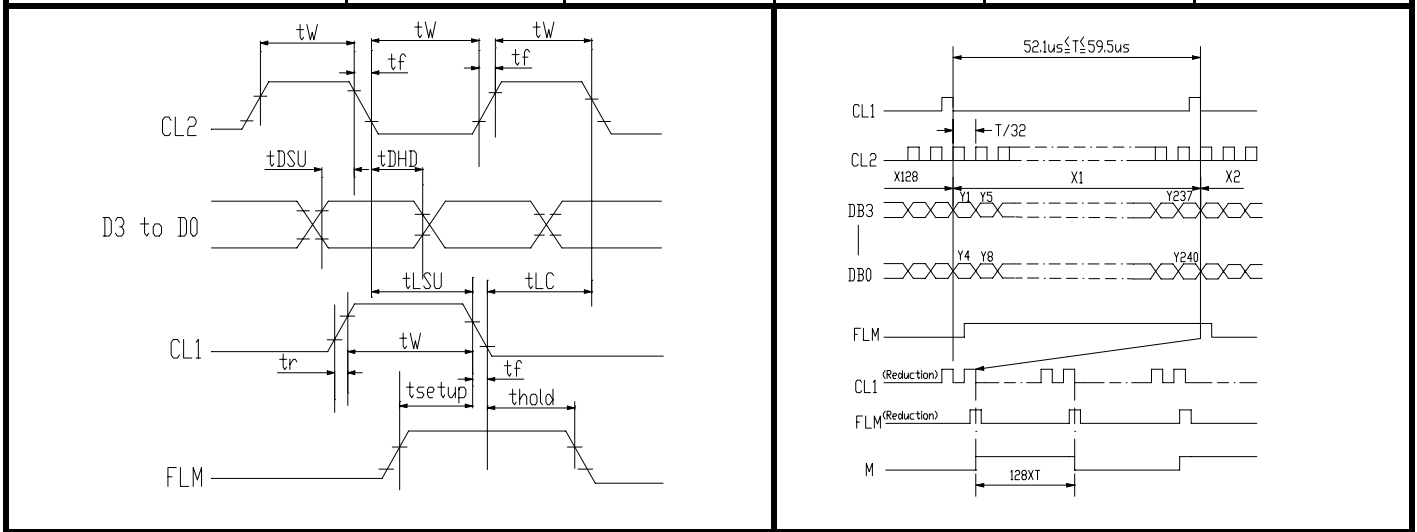

■ BLOCK DIAGRAM

