

承認書

SPECIFICATION FOR APPROVAL

客戶 / CUSTOMER:

日期 / DATE: _____

品名 / PART NAME: _____ 陶 瓷 諧 振 器

規格 / DESCRIPT: _____ 3731 50.00MHz

佑田料號 / OUR PART NO: _____ CRVB50M00T110RO

客戶料號 / CUSTOMER PART NO. _____

本承認書一式()份,請簽回一份。

	工 程	品 管	審 核
UTI			
CUSTOMER			

佑田电子科技有限公司

UTI TECHNOLOGY CO., LTD

地址:中国广东省东莞市长安镇乌沙江贝管理区长通工业园 C 栋
Building C, Chang Tong Industrial Park, Wu-Sha. Jiang-Bei, Chang An
Town, DongGuan City, China.

Tel : +86-769-81503946,82385169,82385849

Fax: +86-769-85311418,85447186

Http:www.uti-globe.com



OUR PART NO: CRVB50M00T110RO

1. Scope

This specification is applied to the ceramic resonator in IC oscillation circuit

2. PART NUMBER

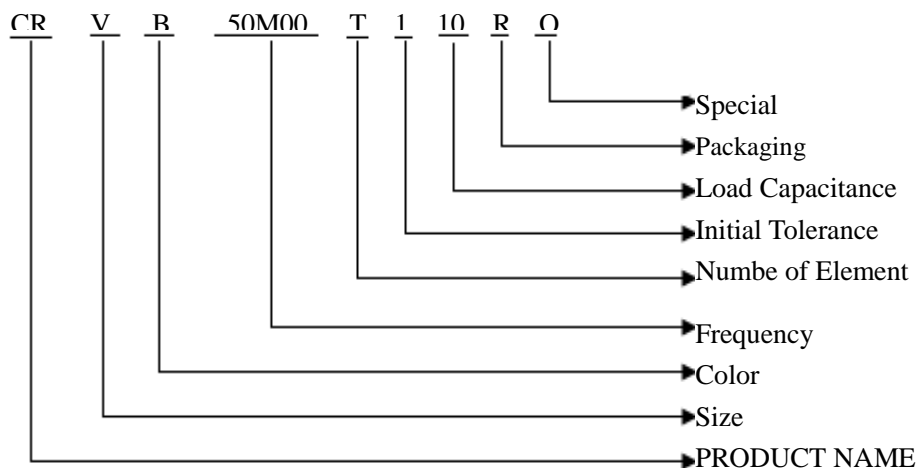

3. ELECTRICAL CHARACTERISTICS

The MHZ ceramic resonator must meet the following performance when tested in the circuit indicated in figure 1 and figure 2.

Measuring condition:temperature(+15~35°C),Humidity(45 ~ 85%RH)

ITEM	SPECIFICATION
Oscillation	50MHz
Initial Tolerance	Within $\pm 0.1\%$
Resonant Impedance	25 Ω Max.
Built-in Load Capacitance	10PF $\pm 20\%$ max.
Insulation Resistance	500M Ω min (applied D. C. 10V)
Withstanding Voltage	D.C 100V, 5seconds max
Rated Working Voltage (1)D.C .Voltage (2)A.C.Voltage	D. C. 6V 15Vp-p
Temperature Stability . Operating Temperature . Storage Temperature	$\pm 0.2\%$ max. (from initial value) -20°C~+80°C -40°C~+85°C
Aging(10years)	$\pm 0.1\%$ max. (from initial value)

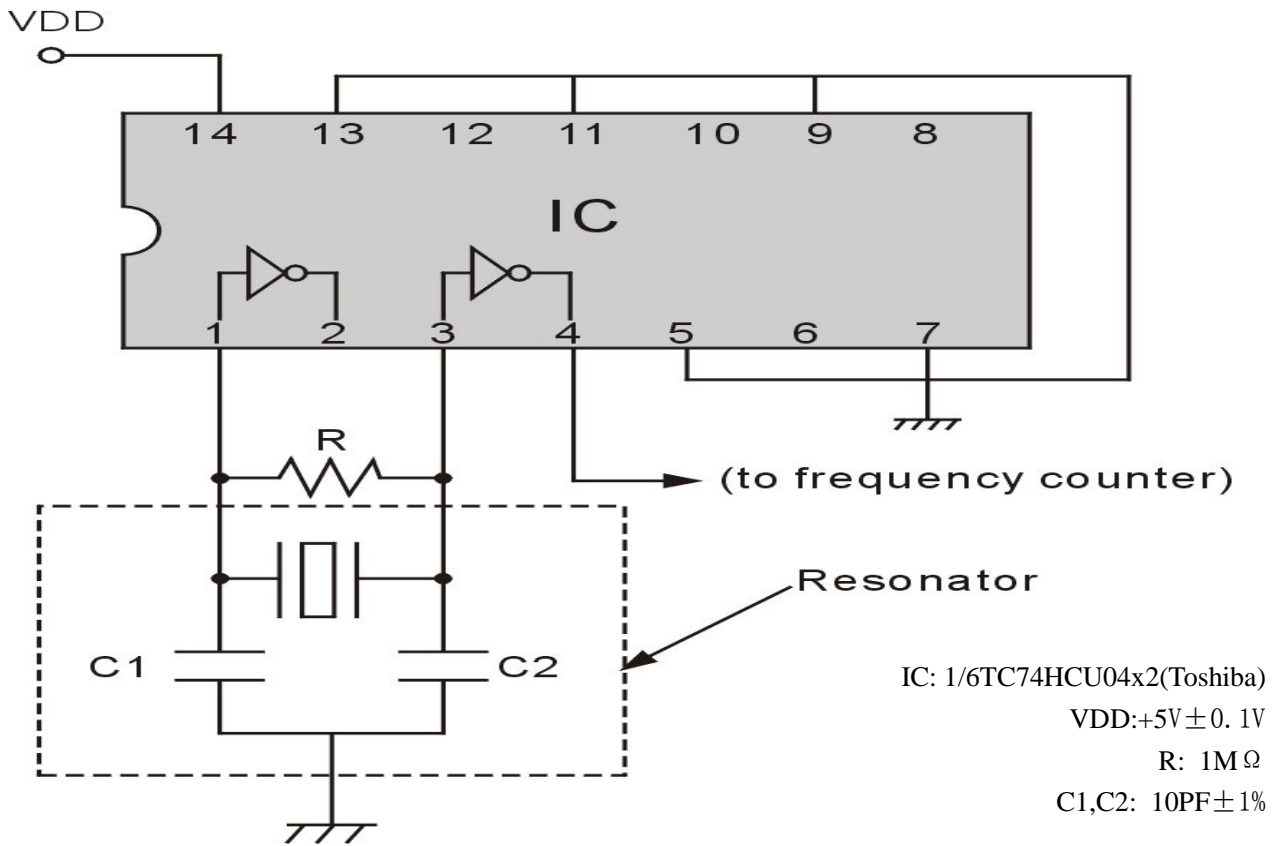

Figure 1. Test Circuit for Oscillating Frequency

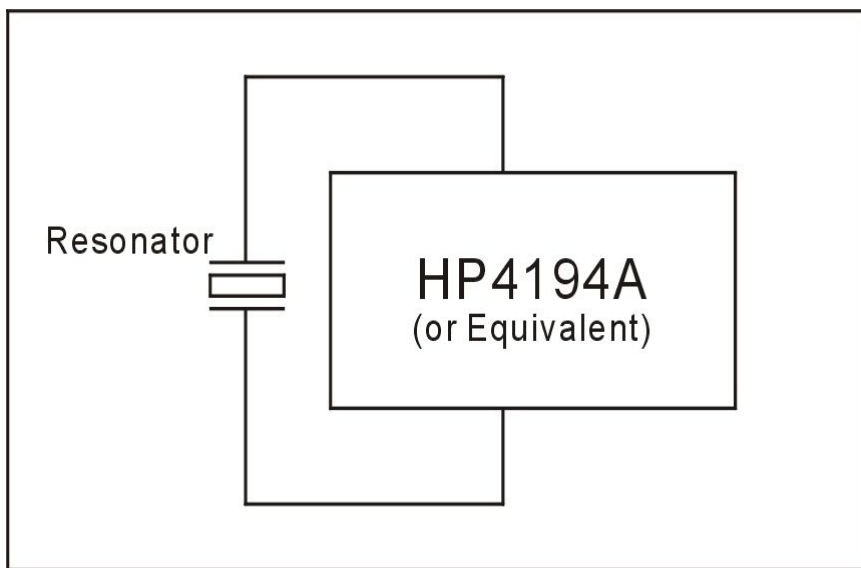

Figure 2. Measurement for Resonant Impedance

4. DIMENSIONS & STRUCTURE

● Marking



● PCB Soldering Land Dimensions

(Unit:mm)

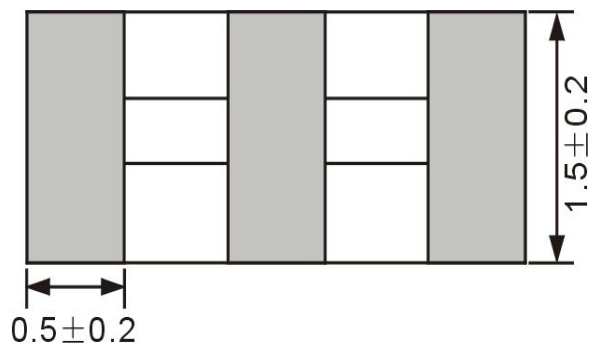
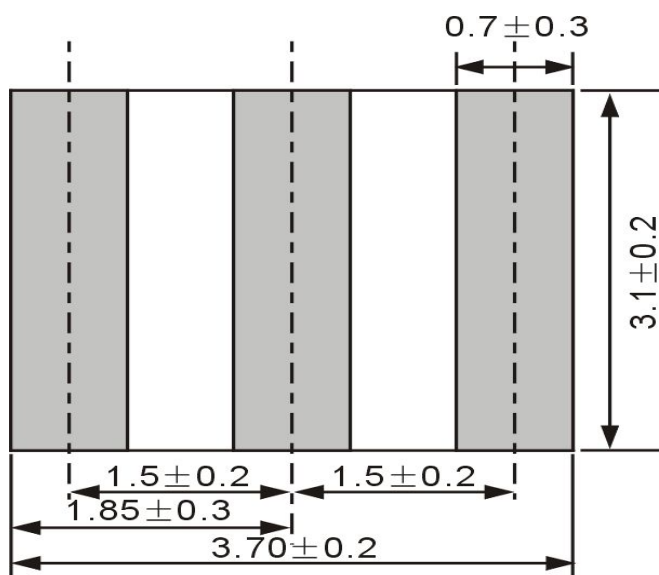
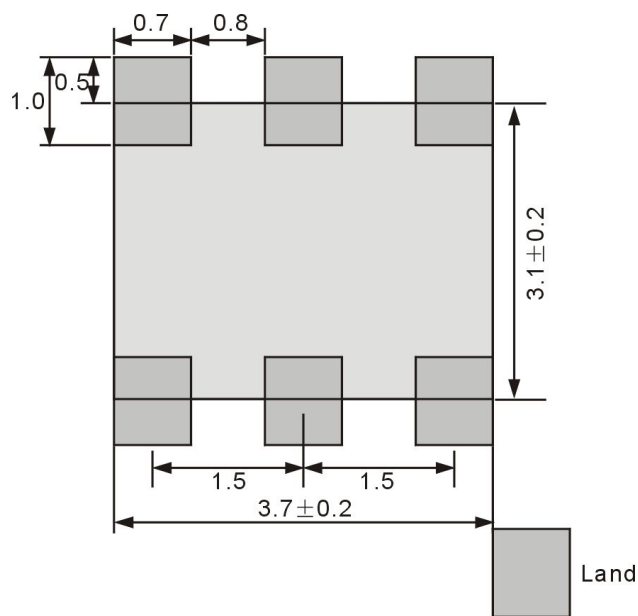

5.ENVIRONEMNTAL & PHYSICAL CHARACTERISTICS

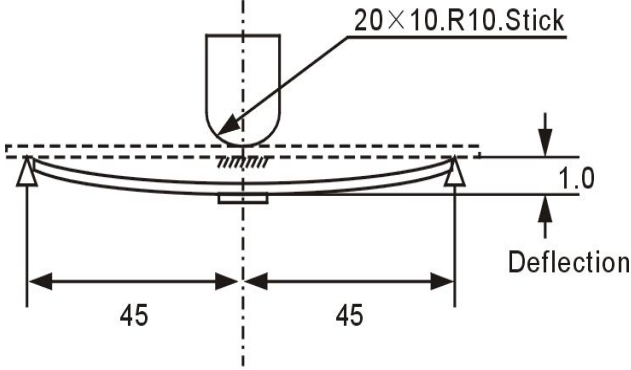
ITEM	CONDITION & REQUIREMENT
5-1. Storage in Hihg Temp	After being placed in a chamber with $+85 \pm 2^{\circ}\text{C}$ for 500 hours and then being placed in natural condition for 2 hour, then measure. →To be satisfied Table 1.
5-2. Storage in low Temp.	After being placed in a chamber with $-55 \pm 2^{\circ}\text{C}$ for 500 hours and then being placed in natural condition for 2 hour, then measure. →To be satisfied Table1.
5-3. Humidity	After being placed in a chamber within $+90$ to 95% R.H. at $+60 \pm 2^{\circ}\text{C}$ for 500 hours and then being placed in natural condition for 2 hour , then measure. →To be satisfied Table 1.
5-4. Heat Shock	After being kept at room temperature , the resonator shall be placed at temperature of -55°C . After 30 minutes at this temperature resonator shall be immediately placed at temperature of $+85^{\circ}\text{C}$. After 30 minutes at this temperature resonator shall be returned to -55°C again .After five above cycles, the resonator shall be returned to room temperature for at least 2 hour, then measure. →To be satisfied Table 1.
5-5. Random Drop	Resonator shall be measured after 3 times random drops from the heigh of 1 m on wooden floor. →No visible damage and the measured values shall meet Table 1.
5-6. Vibration Test	Resonator shall be measured after being applied vibration of amplitude to 1.5mm with 10 to 55Hz band of vibration frequency to each of a perpendicular directions for 2 hours. →No visible damage and the measured values shall meet Table 1.
5-7. Bending strength PCB	<p>Resonator is soldered onto the center of PCB which is laid on the 2 small supporters spaced 90mm. PCB deflected to 3mm below from horizontal level by the pressing force with 20x10. R10 stick. The force is supplied for 1 second , 5 times repeatedly. Velocity of pole for press: 0.5mm/sec.</p>  <p style="text-align: center;">Unit: mm</p> <p>→No visible damage and the measured values shall meet Table 1.</p>

ITEM	CONDITION & REQUIREMENT
5-8. Solderability	End terminals are immersed in rosin for 5 seconds and then immersed in soldening bath of $230 \pm 5^{\circ}\text{C}$ for 3 ± 0.5 seconds. →75% min . End terminals shall be wet with solder.
5-9. Resistance to Soldering Heat (1) Reflow	<p>Following profile of heat stress is applied to resonator, then being place in natural condition for 1 hour, resonator shall be measured.</p>  <p>1. Preheating conditions shall be 140 to 160°C for 60 to 120 seconds. Ascending time up to 150°C shall be longer than 30 seconds.</p> <p>2. Heating conditions shall be within 20 seconds at 230°C min, but peak temperature shall be lower than 240°C.</p>
(2) Soldering Iron	<p>Soldering iron of $270 \pm 5^{\circ}\text{C}$ shall be placed 0.5mm above from electrode of resonator. Melting solder through soldering iron shall be applied to electrode for 3 ± 1 seconds, then being place in natrual condition for 24 hour, resonator shall be measured.</p> <p>→The measured values shall meet Table 1.</p>

TABLE1

MEASUREMENTS	REQUIREMENTS
Oscillating Frequency	$\pm 0.2\%$ max. (from initial value)

6.PACKAGING STANDARD

The products should be packaged for protecting form the accident which could be caused during transportation or preservation ,and part name, quantity and inspection lot No, Shall be .given to the each minimum packing unit. The dimensions of carrier tape reper to the attached sheet.

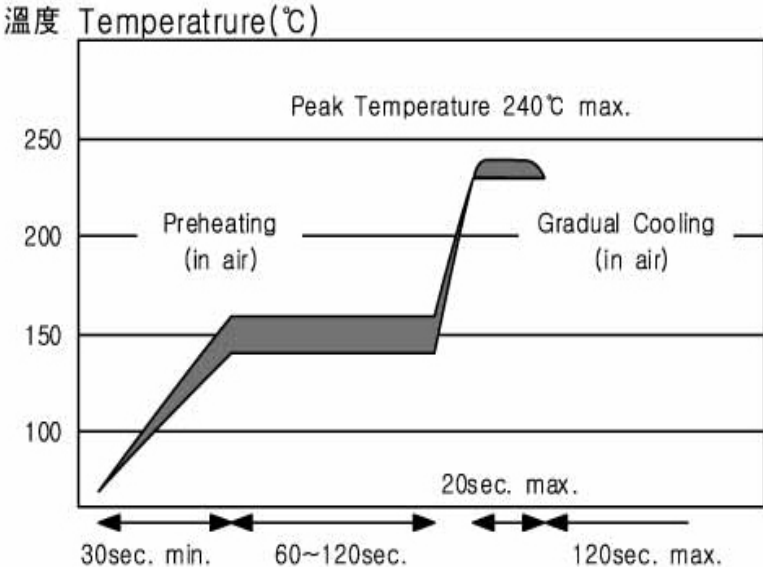
Note) 1 Reel contains 2000 pcs Resonator.

DIMENSIONS OF CARRIER TAPE

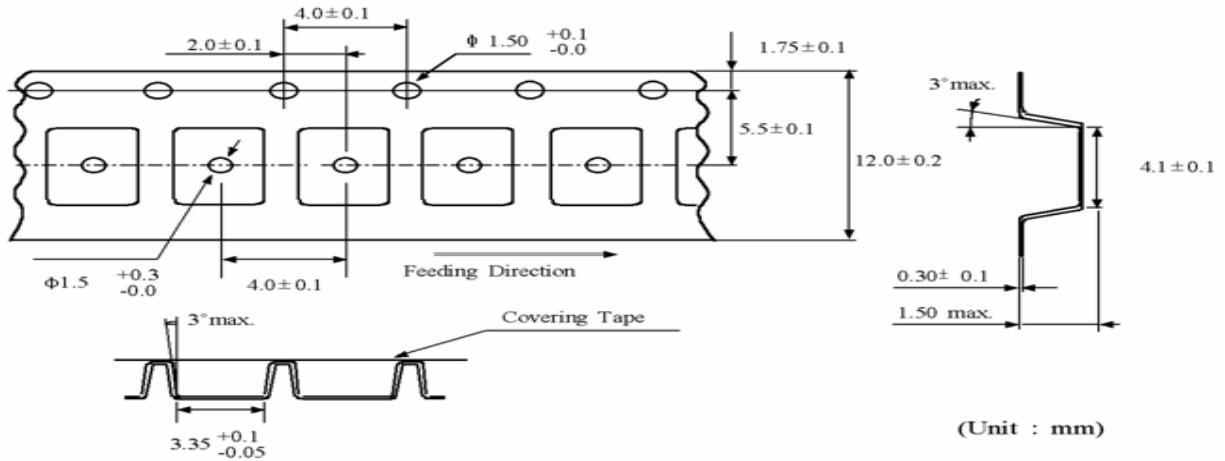

DIMENSIONS OF TAPING REEL

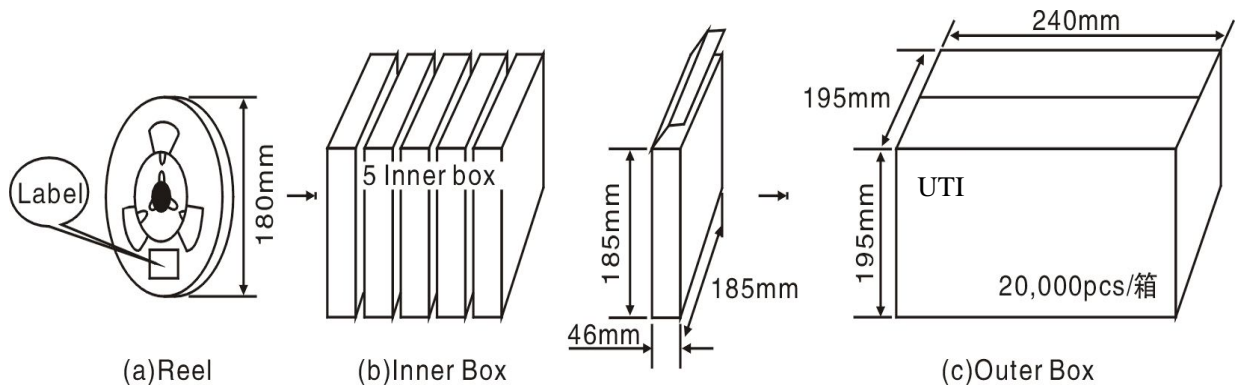
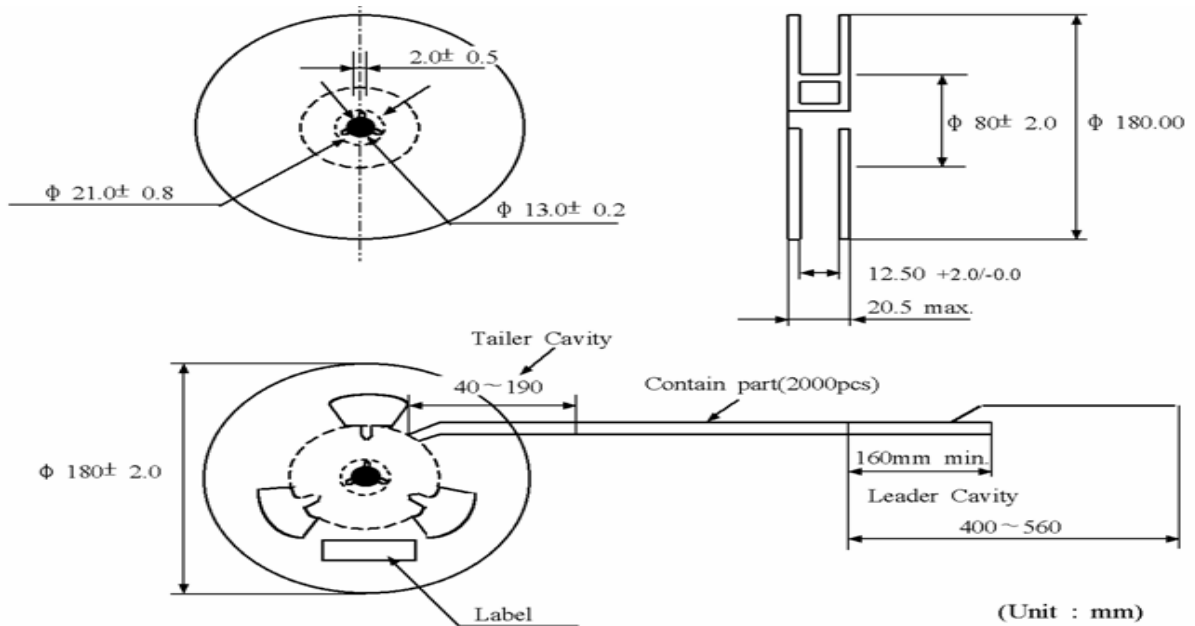

7. CAUTIONS FOR USE

- 7-1. Resonator might be damaged when an excess stress is applied.
- 7-2. Cleaning or washing of the component is not acceptable due to non sealed construction.
Cleaning conditions, such as kinds of cleaning solvents, immersion time and temperatures etc, after soldering shall be checked by experiments before production.
- 7-3. Conformal coating of the component is acceptable. However, the resin material, curing temperature, and other process conditions should be evaluated to confirm stable electrical characteristics are maintained.
- 7-4. Irregular or stop oscillation may occur under unmatched circuit conditions. And it shall be noted that oscillating frequencies of the ceramics Resonator may drift depending on IC applied (the type names, the manufacturer) and capacitance of external capacitors (C1,C2) and the circuit design in figure 1.

8. LIMITATION FOR USAGE

- 8-1. The component is manufactured and promoted to be used in general electronic of AV, home appliance, communication, measurement equipments and machine tools.
- 8-2. Contact us before using our products for the following applications.
 - 1) Aircraft equipment
 - 2) Aerospace equipment
 - 3) Undersea equipment
 - 4) Medical equipment
 - 5) Transportation equipment
 - 6) Traffic signal equipment
 - 7) Disaster prevention/Crime prevention equipment
 - 8) Data-processing equipment
 - 9) Applications of similar complexity or with reliability requirements comparable to the applications listed in the above.These applications requires especially high reliability in order to prevent defects which might directly cause damage to other party's life, body or property.

9. NOTICE

- 9-1. This specification mentions the quality of the component as a single unit. Insure the component is thoroughly evaluated in your application circuit.
- 9-2. Be sure to provide an appropriate fail-safe function on your product to prevent a second damage that may be caused by an abnormality or failure related to our product.
- 9-3. Please do not use this component in any application that deviates from its intended use as noted within the specification.
- 9-4. Return one of this specification after your signature of acceptance. In case of no return within three months from submission date, this specification should be treated as accepted.