

Temperature Compensated Crystal Oscillators (TCXO) Surface Mount Type TCXO (LSI Type) KT2520Y Series for GPS



2.5×2.0mm



Ph Free

RoHS Compliant

Features

- Ultra-miniature SMD type (2.5×2.0×0.9mm)
- Frequency stability : $\pm 0.5 \times 10^{-6} / -30$ to $+85^\circ\text{C}$
- 2.3 to 3.5V drive available
- Reflow compatible

Applications

- GPS Units

How to Order

KT2520Y 16369 A C W 28 T xx
① ② ③ ④ ⑤ ⑥ ⑦ ⑧

① Series	⑥ Supply Voltage
② Output Frequency	28 2.8V 30 3.0V
③ Frequency Tolerance	⑦ Voltage Control Range
A $\pm 0.5 \times 10^{-6}$	TCXO T
④ Lower Operating Temp.	⑧ Option Code
C -30°C	
E -20°C	
G -10°C	
⑤ Upper Operating Temp.	
W $+85^\circ\text{C}$	
V $+80^\circ\text{C}$	
U $+75^\circ\text{C}$	

Specifications

Item	Symbol	Conditions	Min.	Max.	Units
Output Frequency Range	Fo	Standard Frequency: 16.369, 19.2, 24.5535, 26, 27.456			MHz
Frequency Tolerance	F _{tol}	vs Temperature	-0.5	+0.5	$\times 10^{-6}$
		vs Load	-0.2	+0.2	
		vs Voltage	-0.3	+0.3	
Frequency Aging	F _{aging}	Per Year	-1	+1	$\times 10^{-6}$
Storage Temperature Range	T _{stg}		-40	+85	$^\circ\text{C}$
Operating Temperature Range	T _{use}		-30	+85	$^\circ\text{C}$
Supply Voltage	V _{cc}		2.3	3.5	V
Output Level	V _{pp}	10k ohm // 10pF	0.8	—	Vp-p
Current Consumption	I _{cc}		—	2	mA
Symmetry	SYM	@ 50% V _{cc}	40	60	%
Harmonics	—		—	-5	dBc

Dimensions

(Unit: mm)

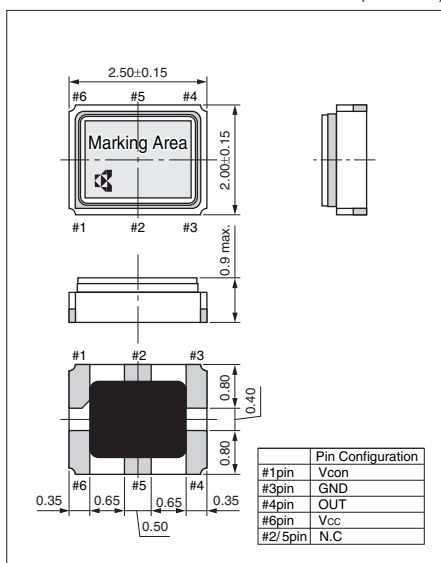

Test Circuit

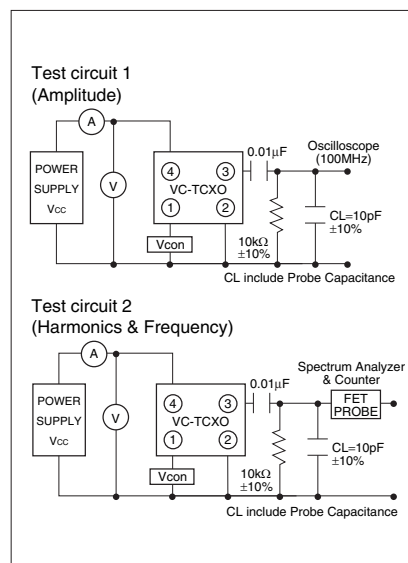

Recommended Land Pattern

(Unit: mm)

