

Thermopile Sensor

OTP-537F2

Revision Date: 2009/08/26



Introduction

The OTP-537F2 is a thermopile sensor in classic TO-5 housing. The sensor is composed of 116 elements of thermocouple in series on a floating micro-membrane having an active diameter of 545 μm and with blacken surface to absorb the incident thermal infrared radiation, which induces a voltage response at output terminals. The sensor chip is fabricated by a unique front-surface bulk micromachining technology, which result in smaller size and faster to response ambient temperature change.

The IR window is a bandpass filter having cut-on wavelength at 5 μm , and cut-down at 14 μm . The sensor responses proportionally to the incident IR radiation and has a constant signal response up to its cut-off frequency, which is limited by the sensor thermal time constant of tens millisecond range.

The OTP-537F2 thermopile sensor provides nearly Johnson-noise-limited performance, which can be calculated by its ohmic series resistance. A thermistor element, with a lead connected to ground, is also provided inside the TO package for ambient temperature reference.

Features

- Non-contact temperature detection
- Voltage output, easy to take signal
- Zero power consumption
- Wide detection temperature range

Applications

- **Medical Application:** *Ear thermometers*
- **Home Facility:** *Microwave oven, Hair dryer, Safety system, Home security & Air conditioner*
- **Industry Application:** *Process monitor and controller, Infrared non-contact thermometers*
- **Automobile Application:** *Thermal sensing system*

Table of Contents

1 General Characteristics

- 1.1 Absolute Maximum Ratings
- 1.2 Handling Guidelines

2 Device Characteristics

- 2.1 Device Descriptions
- 2.2 Sensor Characteristics
- 2.3 Signal Output Characteristics
- 2.4 Frequency Response
- 2.5 Thermistor Characteristics
- 2.6 Optical Characteristics
- 2.7 Filter Characteristics
- 2.8 Mechanic Drawing and Pin Assignment

3 Liability Statement

List of Figures

- Figure 1: Typical output voltage versus object temperature with sensor at 25° C
- Figure 2: Frequency response
- Figure 3: Field of view curve
- Figure 4: Typical spectral transmittance curve
- Figure 5: Mechanical drawing and pin assignment

List of Tables

- Table 1: Absolute maximum ratings
- Table 2: Device characteristics
- Table 3: Thermopile sensor characteristics
- Table 4: Typical numerical data of Thermopile's output voltage (sensor at 25° C)
- Table 5: Thermistor information
- Table 6: Tabulated thermistor data
- Table 7: Optical characteristics
- Table 8: Filter parameters

1. General Characteristics

1.1 Absolute Maximum Rating

Table 1: Absolute maximum rating

Parameter	Min.	Typ.	Max.	Unit
Ambient Operating Temperature	-20		100	°C
Storage Temperature	-40		100	°C

1.2 Handling Guidelines

- Stresses above the absolute maximum ratings may cause damages to the device.
- Do not expose the sensor to aggressive detergents such as Freon, Trichloroethylene, etc.
- Avoid touching or cleaning of the window. If necessary, do cleaning only very carefully with alcohol and cotton swab.
- Hand soldering and wave soldering may be applied by a maximum temperature of 260 °C for a dwell time less than 10 s. Reflow soldering is not recommended.

2. Device Characteristics

2.1 Device Descriptions

The materials of OTP-537F2 are lead-free and fully complied with the RoHS regulations.

Table 2: Device characteristics

Parameter	Description
Cap	Metal cap with integrated IR window
Header	TO 5
Leads	(3 isolated + 1 ground) pins with solderable gold coating
Filter	Si-based IR filter
Insulation gas sealing	The sensor is sealed hermetically in a nitrogen environment.

2.2 Sensor Characteristics

Table 3: Thermopile sensor characteristics

Parameter	Min	Typ	Max	Unit	Conditions
Output Voltage	0.484	---	0.867	mV	T _{amb.} =25°C T _{obj.} =50°C
Sensitivity	70	85	100	V/W	*
TC of sensitivity	---	0.11	---	%/K	Typical
Sensitivity area in diameter	---	545	---	μm	Interference layer
Resistance of thermopile	50	65	80	KΩ	25°C
TC of resistance	---	0.09	---	%/K	Typical
Time constant	---	16	---	ms	*
Noise voltage	28	32	36	nV/Hz ^{1/2}	
NEP	0.28	0.36	0.48	nW/Hz ^{1/2}	
Normalized detectivity (D*)	1.0*10 ⁸	1.3*10 ⁸	1.7*10 ⁸	cm*Hz ^{1/2} /W	*

Notes: * All optical performances are measured at 1 Hz chopper frequency using a blackbody radiator of 500K temperature with filtered spectrum ranging from 5 to 14 μm. Distance between packaged thermopile and blackbody is 11cm.

2.3 Signal Output Characteristics

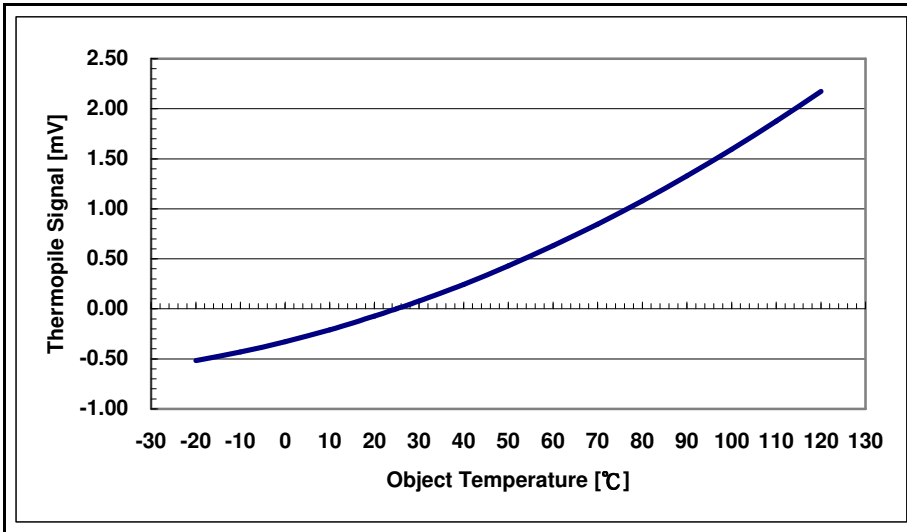

Figure 1: Typical output voltage versus object temperature with sensor at 25° C.

Table 4: Typical numerical data of Thermopile's output voltage (sensor at 25° C)

Temp. (°C)	V_out (mV)	Temp. (°C)	V_out (mV)
-20	-0.52	50	0.43
-10	-0.43	60	0.63
0	-0.33	70	0.85
10	-0.21	80	1.08
20	-0.07	90	1.33
25	0.00	100	1.59
30	0.08	110	1.87
40	0.25	120	2.17

Note: Blackbody source size: 250 x 250mm
Distance from sensor to source: 110mm

2.4 Frequency Response

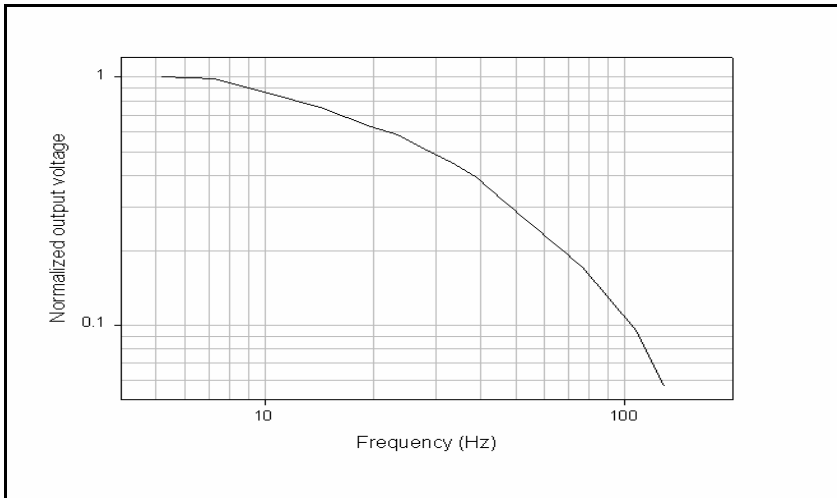

Figure 2: Frequency response

2.5 Thermistor Characteristics

Table 5: Thermistor information

Parameter	Min	Typ	Max	Unit	Conditions
Resistance	29.1	30.0	30.9	KΩ	25°C
β value	3773	3811	3849	K	0°C/50°C

Table 6: Tabulated thermistor data

Temp.(°C)	Resistance (KΩ)		
	Min	Center	Max.
-20	285.7	271.2	256.7
-15	216.6	206.2	195.8
-10	165.5	158.0	150.5
-5	127.6	122.1	116.6
0	98.97	94.98	90.99
5	77.37	74.43	71.49
10	60.91	58.74	56.57
15	48.29	46.68	45.07
20	38.49	37.29	36.09
25	30.90	30.00	29.10
30	25.05	24.27	23.49
35	20.42	19.74	19.06
40	16.74	16.15	15.56

Temp.(°C)	Resistance (KΩ)		
	Min	Center	Max.
45	13.79	13.28	12.77
50	11.41	10.97	10.53
55	9.491	9.108	8.725
60	7.932	7.599	7.266
65	6.656	6.366	6.076
70	5.611	5.358	5.105
75	4.752	4.530	4.308
80	4.037	3.843	3.649
85	3.443	3.273	3.103
90	2.949	2.799	2.649
95	2.534	2.402	2.270
100	2.181	2.064	1.947
105	1.891	1.788	1.685

2.6 Optical Characteristics

Table 7: Optical characteristics

Parameter	Min	Typ	Max	Unit	Conditions
Field of view		46		degree	At 50% target signal

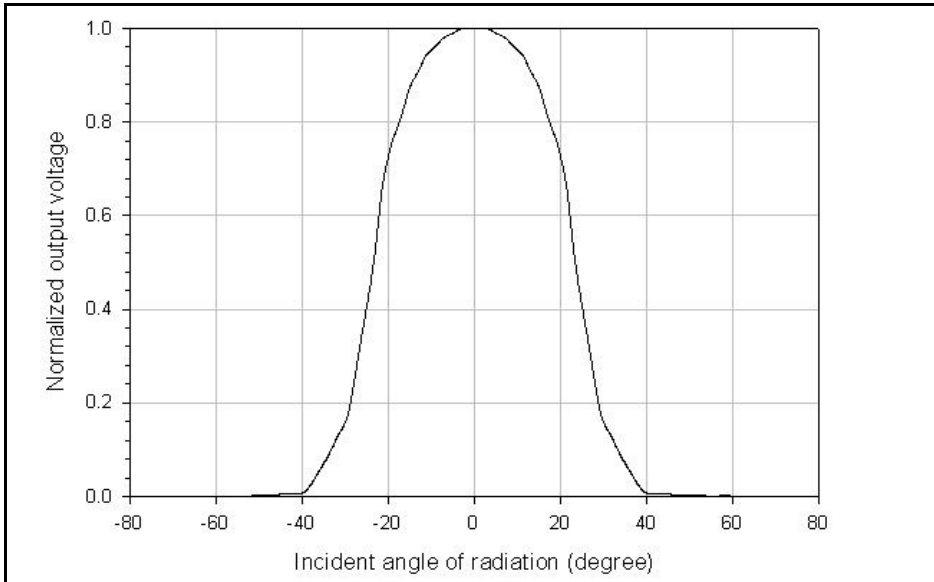

Figure 3: Field of view curve

2.7 Filter Characteristics

Table 8: Filter parameters

Parameter	Min	Typ	Max	Unit	Conditions
Cut on wavelength	4.7	5.0	5.3	μm	At 25°C, 50% transmittance

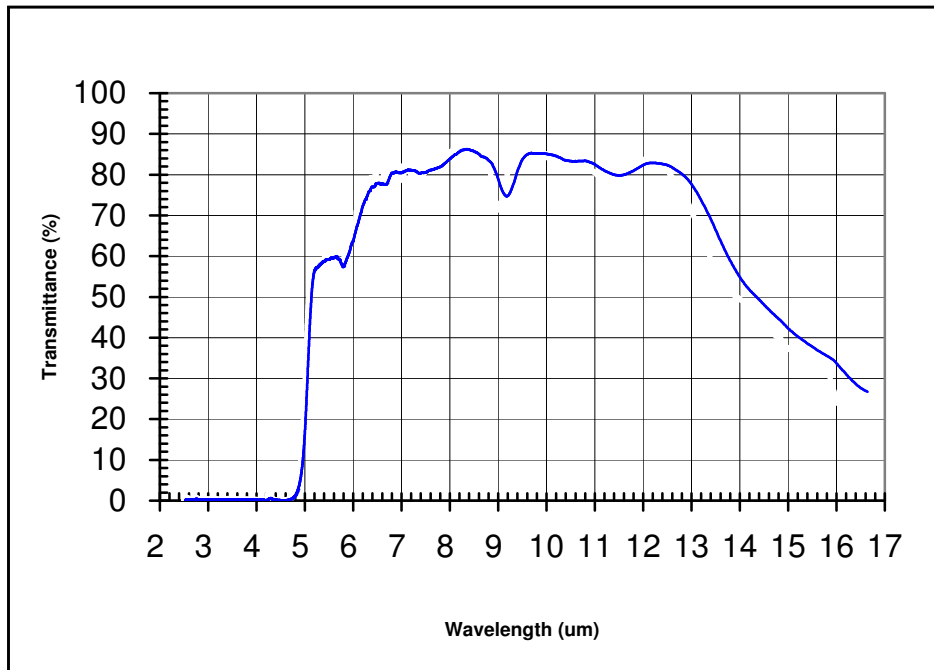

Figure 4: Typical spectral transmittance curve

2.8 Mechanic Drawing and Pin Assignment

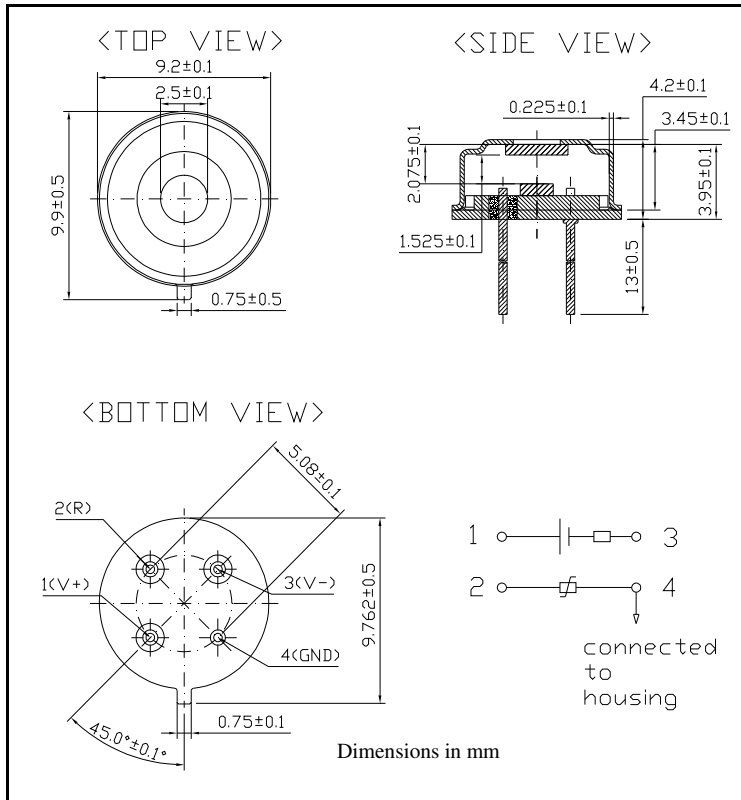

Figure 5: Mechanic drawing and pin assignment

3. Liability Statement

The contents of this document are subject to change without notice and customers should consult with Oriental System Technology (OST) sales representatives before ordering. Customers considering the use of OST thermopile devices in applications where failure may cause personal injury or property damage, or where extremely high levels of reliability are demanded, are requested to discuss their concerns with OST sales representatives before such use. The Company's responsibility for damages will be limited to the repair or replacement of defective product. As with any semiconductor device, thermopile sensors or modules have a certain inherent rate of failure. To protect against injury, damage or loss from such failures, customers are advised to incorporate appropriate safety design measures into their product.

Oriental System Technology Inc.
 2F., No. 25 Industry E. Road 9th,
 Hsinchu Science Park,
 Hsinchu 30075, Taiwan
 Tel: 886-3-5785177
 Fax: 886-3-5787070
 sales@orisystem.com
 http://www.orisystem.com