



廈門科蘭光電科技有限公司
Kelán Optoelectronics Technology Co., Ltd

产品规格书

Specification on Product

产品名称： 红外遥控接收放大器

(DESCRIPTION) : INFRARED MODULE FOR REMOTE CONTROL SYSTEM

产品型号 (MODEL) : KS60..系列

打印标识 (MARK) : KS60..

TEL: 86) (0592) 577 0808 577 0909
001) 925 9222 669

FAX: 86) (0592) 392 1156

E-mail: kelan@kl-tek.com

Website: www.kl-tek.com

ADDRESS: 廈門國家留學人員創業園偉業樓 N102

P. C : 361009

● 概述 (Description) :

KS60..系列是一种集成了光探测器和前置放大器的微型红外遥控接收放大装置。环氧封装可以滤除可见光的干扰，检波输出的信号可直接由微处理译码，KS60..系列是标准的红外遥控接收放大装置，支持所有主要的传输代码。 (*超小型直立式*)

The KS60.- series are miniaturized receivers for infrared remote control systems. PIN diode and preamplifier are assembled on leadframe, the epoxy package is designed as IR filter.

The demodulated output signal can directly be decoded by a microprocessor, KS60.. is the standard IR remote control receiver series, supporting all major transmission codes.

● Parts Table

Type	fo	type	fo	type	fo
KS6030	30KHz	KS6033	33KHz	KS6036	36KHz
KS6037	36.7KHz	KS6038	38KHz	KS6056	56KHz

● 特点 (Features):

- ◆ 没有外围元件，可靠性高 (No external parts, high reliability)
- ◆ 内部屏蔽，抗干扰能力强 (Inner shield, good anti-interference ability)
- ◆ 2.6~5.6V 供电电压，功耗低 (2.6~5.6V supplied voltage, low power consumption)
- ◆ 灵敏度高，传输范围大 (High sensitivity, large transmission range)
- ◆ TTL 和 CMOS 兼容 (Capability of TTL & CMOS)

● 极限参数 (Ta=25°C) (Absolute Maximum Ratings, Ta=25°C)

参数 Parameters	符号 Symbol	额定值 Rated value	单位 Unit
电源电压 Supply voltage	V _S	5.5	V
电源电流 Supply current	I _S	5.0	mA
工作温度 Operation Temp.	T _{amb}	-25~+105	°C
贮存温度 Storage Temp.	T _{stg}	-25~+105	°C
焊接温度 (5 秒) Soldering Temp. (5s)	T _{sd}	+260	°C

● 光电参数 (Ta=25°C) (Opto-electric characteristics, Ta=25°C)

参数 Parameters	符号 symbol	测试条件 Test condition	最小值 Min.	典型值 Typ.	最大值 Max.	单位 Unit
电源电流 Supply current	I _{CC}	V _S =5V Ev=0		0.8	1.25	mA
峰值波长 Peak wavelength	λ _P			940		nm
调制频率 Modulated freq.	f ₀			37.9		KHZ
高电平输出电压 High output voltage	V _{OH}	Ev=0.5mw/m ²	4.5			V
低电平输出电压 Low output voltage	V _{OL}	周期=1.2ms (Cycle=1.2ms)			0.4	V
高电平输出脉宽 High output pulse width	T _{Wh}	占空比=50% (Duty=50%)	400	600	800	μS
低电平输出脉宽 Low output pulse width	T _{wl}		400	600	800	μS
接收距离 Receiving distance	L	V _S =5V Ev=(200±50)Lx	16(0deg) 7(±45deg)			M
受控角 Controlled angle	Δθ	V _S =5V Ev=(200±50)Lx L=6.5M		±45		deg

● 标识 (Mark)

在产品顶部打印产品型号和生产批号，如下：

Print type model and LOT.NO. on the back of product as follow:

$\begin{array}{cccccc} \underline{K} & \underline{S} & \underline{00} & \underline{38} & \underline{-10} & \underline{-W} \\ | & | & | & | & | & | \\ & (2) & (3) & (4) & (5) & (6) \\ (1) & & & & & \end{array}$

- (1): 标志 (KL mark) (2): 公司内定的红外遥控接收放大器的简称 (如: 字母 S 代表红外遥控接收放大器) (3): 产品特征、功能、外观的类别代码 (如: 00 表示它是环氧灌封、芯片使用德国进口, 电压的类型是 5V 的。这个在以下的说明书里会有详细的说明)
- (4): 红外遥控接收放大器的接收频率 (如: 38 表示它使用的频率是 38kHz)
- (5): 外加铁壳的型号 (如: -10 表示它使用的铁壳型号是 -10 的)
- (6): 打弯尺寸 (如: -W 表示从管体顶部到支架打弯点的距离为 10.8mm)



● 包装 (Package)

包装采用防静电塑料条管和外包装纸箱，外包装箱上应有符合 GB191 中规定的相应运输要求的标志以及标明公司名称、商标、地址、产品名称、型号、数量等，并贴有封讫，箱内应有合格证，标明型号、生产日期及检验员代号等。

The parts are put into antistatic plastic tubes which are packed in cartons. On the carton, followings are printed: mark of transportation stipulated in GB191, Company Name, Trade mark, Address, Product Description, Model and Quantity. Sealing mark is stucked on the carton too. Inside the carton there are qualification certificate, stated model, production date and inspector' s code.



● 可靠性试验要求 (Reliability Test)

组别 GROUP	试验项目 TEST ITEM	试样 SAMPLE NUMBER	试验条件 TEST CONDITIONS	指标 TECHNICAL DATA	合格 OK. NUM
1	耐焊接热试验 Soldering heat Durability test	16	(260±5) °C, (10±1) S, 浸渍到离器件本体 (2-2.5) mm the distance from the body to merging (2-2.5) mm	恢复 1 小时后, 测试光电参 数符合表二要求 After resuming for 1 hour, test photoelectric parameters in Table 2.	16
2	温度快速变化 Temp. Fast Changing	12	Ta=(-25±3) °C、Tb=(85±2) °C 暴露时间: 10 分钟 Exposure duration:10 min. 转移时间: (2-3) 分钟 Transfer duration:2-3 min. 循环次数: 5 次 Circulation:5cycles. 恢复 2 小时后, 做循环湿热试验. After resuming for 2 hours, do the experiments of circulating humidity & heat.	恢复 4 小时后, 测试光电参 数符合表二要求. After resuming for 4 hour, test photoelectric parameters in Table 2.	12
	循环湿热 Circulating Humidity & Heat.		(55±2) °C, 2 次 (2 cycles)		
3	电耐久性 Operating Life	25	Vs=5V, Ev=0.5mW/m ² , 1000h	恢复 4 小时后, 测试下列光 电参数: After resuming for 4 hour, test the following parameters : 距离 (distance) :L≥16M 受控角 (angle) : △θ ≥ ±48deg	25
4	高温贮存 High Temp. Storage	16	85±2 °C, 1000h	恢复 4 小时后, 测试光电参 数符合表二要求. After resuming for 4 hour, test photoelectric parameters in Table 2.	16

● 特性曲线(Characteristics Curve) ($T_{amb}=25^{\circ}C$ unless otherwise specified)

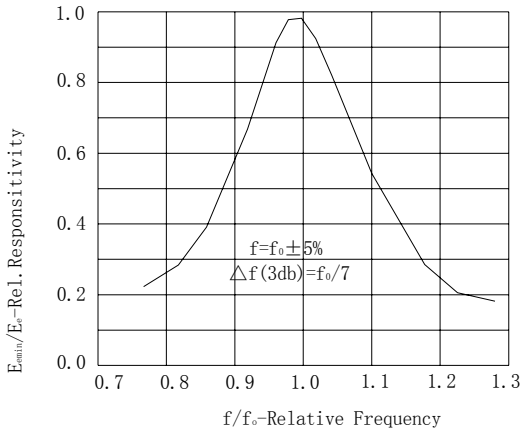

Figure 1. Frequency Dependence of Responsivity

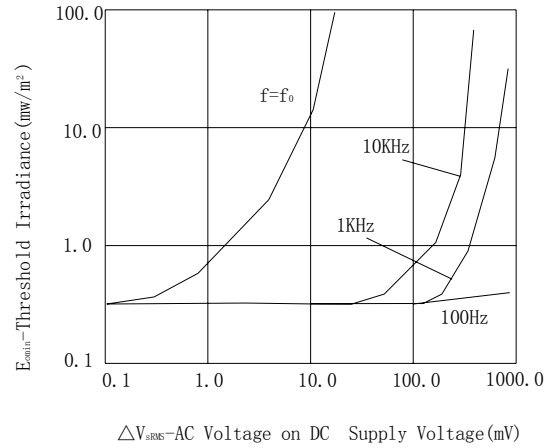

Figure 2. Sensitivity vs. Supply Voltage Disturbances

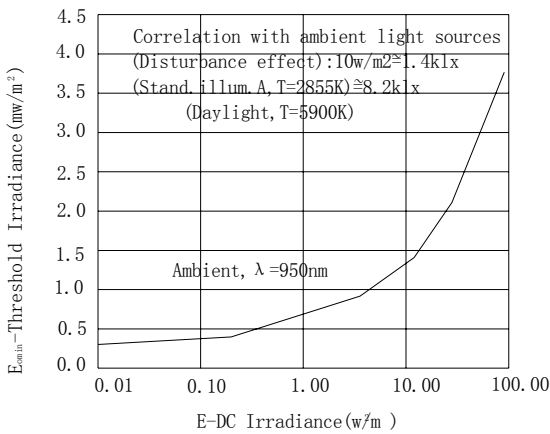

Figure 3. Sensitivity in Bright Ambient

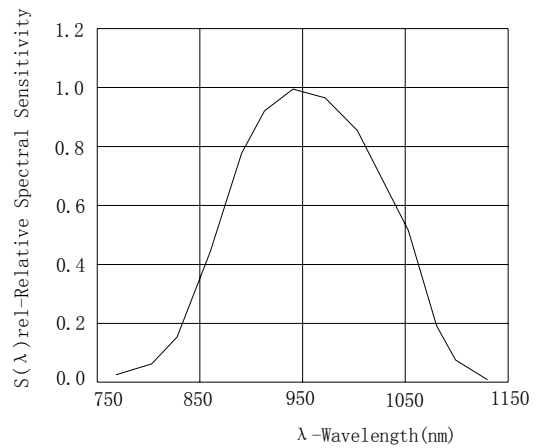

Figure 4. Relative Spectral Sensitivity vs. Wavelength

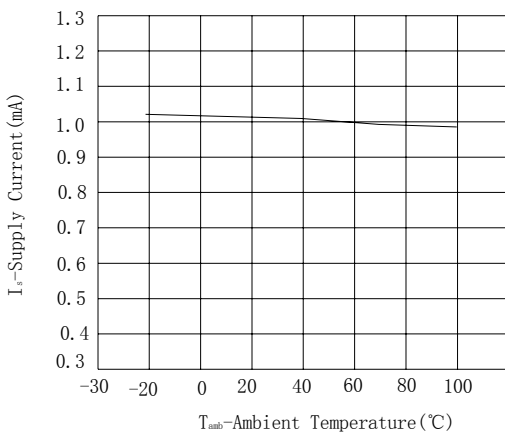

Figure 5. Supply Current vs. Ambient Temperature

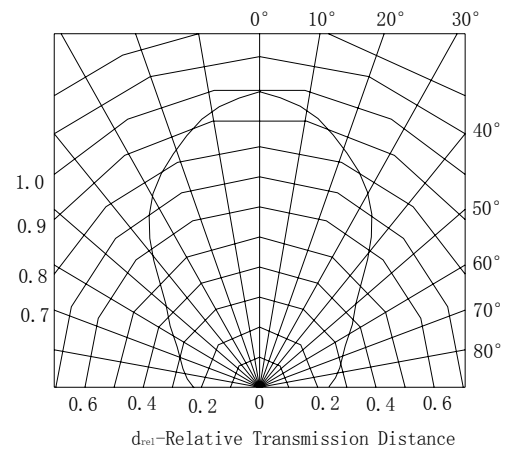
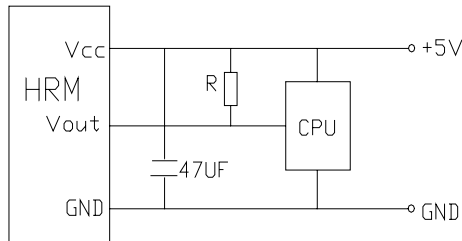

Figure 6. Directivity

推荐应用线路 (Recommended circuit) -fig.1



注: (1) 当负载电阻为32.4KΩ时, 推荐外接上拉电阻R在1.6-8.5KΩ。

(2) 当负载电阻改变, R也应作相应调整。

NOTE: (1) When load is 32.4KΩ, 1.6-8.5KΩ external pull-up resistor (R) is recommended.

(2) R shall be adjusted with changing of load.

● Block diagram

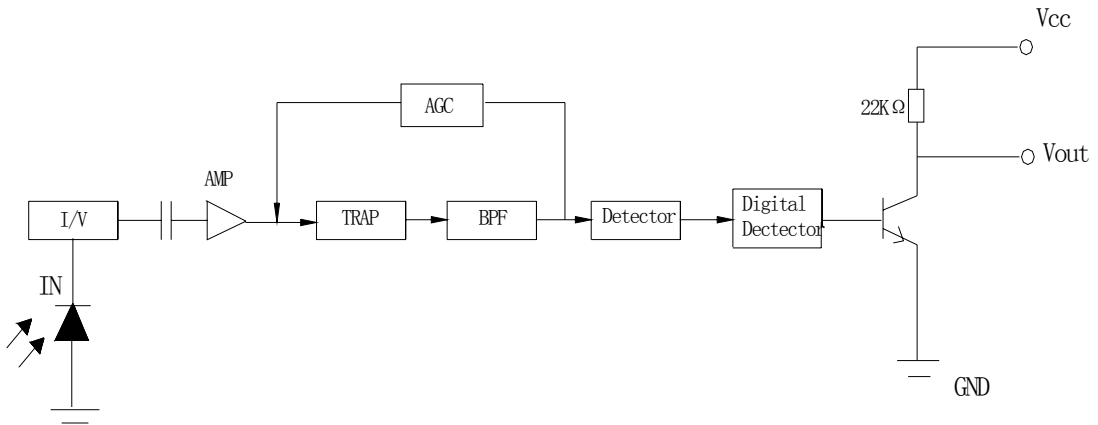

● 外形图 (Outline)

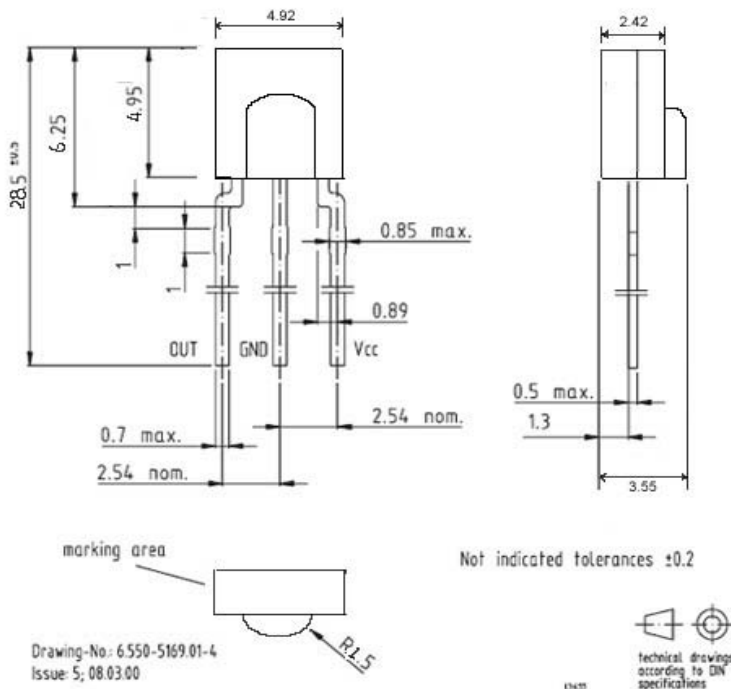



● 使用注意事项 (Precautions for use)

1. 该产品为静电敏感元件，要求使用时人和所有的装置(包括烙铁)、设备、机器、桌子、地面等都必须采取防静电措施。

Since the device is static sensitive, it is requested that anti-static measures should be taken on human body, all devices (including soldering iron) and equipment, machinery, desk and ground.

2. 不要对引脚施加不必要的外力。

Do not supply unnecessary stress to lead.

3. 注意保护接收器的接收面，沾污后会影晌接收性能，同时不要触碰接收表面。

Please pay careful attention to the lens of receivers, It might has a chance to miss-function when the lens get dust or dirty. And also please do not touch the lens.