

Trimmable Thick Film Chip Resistor – RT Series

Construction

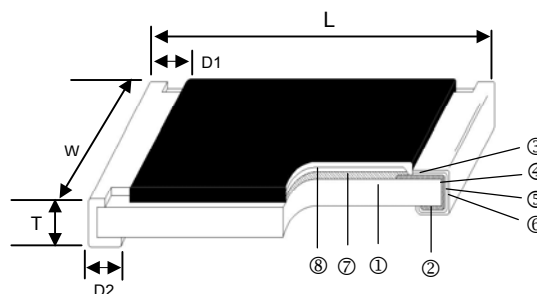

① Alumina Substrate	④ Edge Electrode (NiCr)	⑦ Resistor Layer (RuO ₂ /Ag)
② Bottom Electrode (Ag)	⑤ Barrier Layer (Ni)	⑧ Primary Overcoat (Glass)
③ Top Electrode (Ag-Pd)	⑥ External Electrode (Sn)	

Features

- Suitable for laser fine tune
- Small size and light weight
- Highly reliable multilayer electrode construction
- Compatible with all soldering process

Applications

- Tuner
- Sensor Control Circuit
- Camcorder
- Portable Audio
- Photo Sensor
- Portable Measuring Equipment

Dimensions

Unit: mm

Type	Size (Inch)	L	W	T	D1	D2	Weight (g) (1000pcs)
RT-02	0402	1.00±0.05	0.50±0.05	0.35±0.05	0.20±0.10	0.20±0.10	0.620
RT-03	0603	1.60±0.10	0.80±0.10	0.45±0.10	0.30±0.20	0.30±0.20	2.042
RT-05	0805	2.00±0.10	1.25±0.10	0.50±0.10	0.35±0.20	0.40±0.20	4.368
RT-06	1206	3.10±0.10	1.55±0.10	0.55±0.10	0.50±0.25	0.50±0.20	8.947
RT-10	1210	3.10±0.10	2.60±0.15	0.55±0.10	0.50±0.25	0.50±0.20	15.959
RT-0A	2010	5.00±0.10	2.50±0.15	0.55±0.10	0.60±0.25	0.50±0.20	24.241
RT-12	2512	6.35±0.10	3.10±0.15	0.55±0.10	0.60±0.25	0.50±0.20	39.448

Part Numbering

RT-	03	F	L	7	---1R2
Product Type	Dimensions	Resistance Tolerance	Function Code	Packaging Code	Resistance
	02: 0402 03: 0603 05: 0805 06: 1206 10: 1210 0A: 2010 12: 2512	N: 0~10% P: 0~20% Q: 0~30%	L: Standard	4: 7" Reel 4Kpcs 6: 7" Reel 10Kpcs 7: 7" Reel 5Kpcs 9: 10" Reel 8Kpcs A: 10" Reel 10Kpcs B: 10" Reel 20Kpcs C: 13" Reel 40Kpcs D: 13" Reel 20Kpcs F: Bulk	--- 1R2: 1.2Ω --- 3K3: 3.3KΩ --- 10K: 10KΩ -- 100K: 100KΩ "-" to fill up 6 spaces

Derating Curve

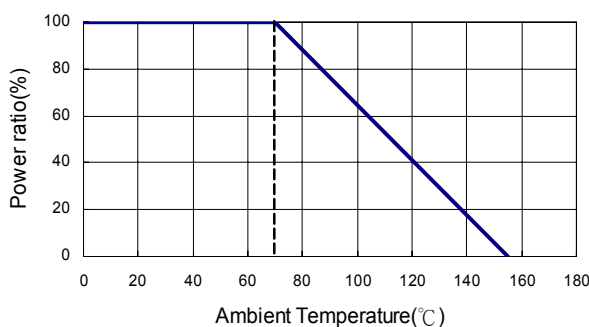

Standard Electrical Specifications

Type \ Item	Power Rating at 70°C	Operating Temp. Range	Max. Operating Voltage	Max. Overload Voltage	Resistance Range			TCR (PPM/°C)
					0~ -10%	0~ -20%	0~ -30%	
RT-02 (0402)	1/16W	-55 ~ +155°C	50V	100V	1Ω - 10MΩ			±200
RT-03 (0603)	1/10W		50V	100V	1Ω - 9.76Ω 10Ω - 1MΩ 1.02MΩ - 10MΩ			±200 ±100 ±200
RT-05 (0805)	1/8W		150V	300V				
RT-06 (1206)	1/4W		200V	400V				
RT-10 (1210)	1/3W		200V	400V				
RT-0A (2010)	3/4W		200V	400V				
RT-12 (2512)	1W		250V	500V				

Operating Voltage= $\sqrt{P \cdot R}$ or Max. operating voltage listed above, whichever is lower.

Overload Voltage= $2.5 \cdot \sqrt{P \cdot R}$ or Max. overload voltage listed above, whichever is lower.

■ Viking is capable of manufacturing the optional spec based on customer's requirement.

Environmental Characteristics

Item	Requirement	Test Method
Temperature Coefficient of Resistance (T.C.R.)	As Spec.	-55°C~+125°C, 25°C is the reference temperature
Short Time Overload	$\pm(1.0\%+0.05\Omega)$	RCWV*2.5 or Max. overload voltage for 5 seconds
Insulation Resistance	$\geq 10G$	Max. overload voltage for 1 minute
Endurance	$\pm(2.0\%+0.10\Omega)$	70±2°C, Max. working voltage for 1000 hrs with 1.5 hrs "ON" and 0.5 hrs "OFF"
Damp Heat with Load	$\pm(2.0\%+0.10\Omega)$	40±2°C, 90~95% R.H. Max. working voltage for 1000 hrs with 1.5 hrs "ON" and 0.5 hrs "OFF"
Dry Heat	$\pm(1.0\%+0.05\Omega)$	at +155°C for 1000 hrs
Bending Strength	$\pm(1.0\%+0.05\Omega)$	Bending once for 5 seconds 2010, 2512 sizes: 2mm Other sizes: 3mm
Solderability	95% min. coverage	245±5°C for 3 seconds
Resistance to Soldering Heat	$\pm(0.5\%+0.05\Omega)$	260±5°C for 10 seconds
Voltage Proof	No breakdown or flashover	1.42 times RCWV (RMS) for 1 minute
Leaching	Individual leaching area $\leq 5\%$ Total leaching area $\leq 10\%$	260±5°C for 30 seconds
Rapid Change of Temperature	$\pm(0.5\%+0.05\Omega)$	-55°C to +155°C, 5 cycles

■ Reference Standards: IEC 60115-1, 60068-2-58; JIS-C 5201-1

■ Storage Temperature: 25±3°C; Humidity < 80%RH

Packaging

Reel Specifications & Packaging Quantity

Unit: mm

Type	Packaging Quantity	Tape Width	Reel Diameter	ΦA	ΦB	ΦC	W	T
RT-02	Paper	10K	7 inch	178.5±1.5	60 ^{+1/-0}	13.0±0.2	9.0±0.5	12.5±0.5
		20K						
		40K						
RT-03 RT-05 RT-06 RT-10	Paper	5K	10 inch	254±1.0	100±0.5	13.0±0.2	9.5±0.5	13.5±0.5
		10K						
		20K						
RT-0A RT-12	Embossed	4K	7 inch	178.5±1.5	60 ^{+1/-0}	13.0±0.5	13.0±0.5	15.5±0.5
		8K						

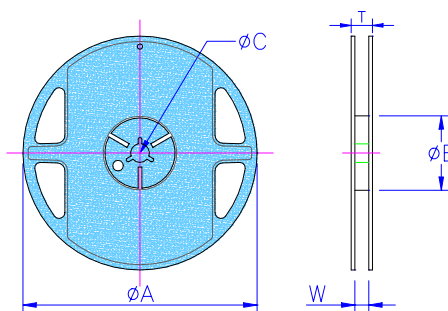

Paper Tape Specifications

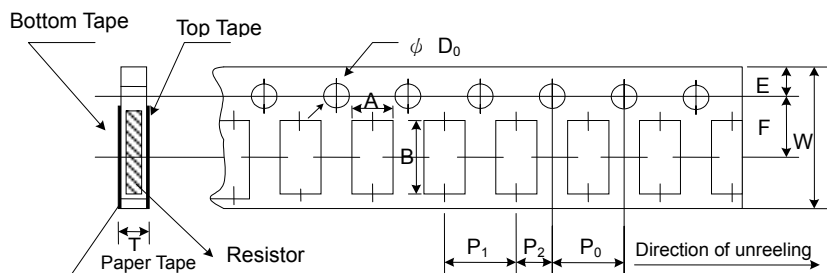

Unit: mm

Type	A	B	W	E	F	P ₀	P ₁	P ₂	ΦD ₀	T
RT-02	0.65±0.10	1.15±0.10	8.0±0.20	1.75±0.10	3.50±0.05	4.00±0.10	2.00±0.05	2.00±0.05	1.50+0.1,-0	0.45±0.10
RT-03	1.10±0.10	1.90±0.10	8.0±0.20	1.75±0.10	3.50±0.05	4.00±0.10	4.00±0.05	2.00±0.05	1.50+0.1,-0	0.70±0.10
RT-05	1.60±0.10	2.40±0.20	8.0±0.20	1.75±0.10	3.50±0.05	4.00±0.10	4.00±0.05	2.00±0.05	1.50+0.1,-0	0.85±0.10
RT-06	1.90±0.10	3.50±0.20	8.0±0.20	1.75±0.10	3.50±0.05	4.00±0.10	4.00±0.05	2.00±0.05	1.50+0.1,-0	0.85±0.10
RT-10	2.90±0.10	3.50±0.20	8.0±0.20	1.75±0.10	3.50±0.05	4.00±0.10	4.00±0.05	2.00±0.05	1.50+0.1,-0	0.85±0.10

Embossed Plastic Tape Specifications

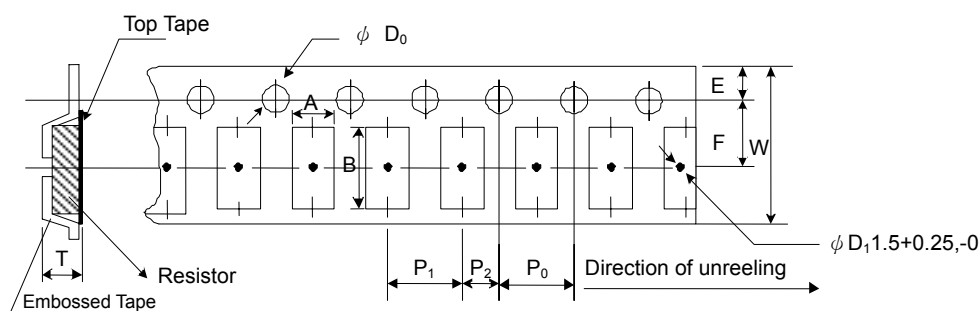

Unit: mm

Type	A	B	W	E	F	P ₀	P ₁	P ₂	ΦD ₀	T
RT-0A	2.8±0.10	5.5±0.10	12.0±0.30	1.75±0.10	5.5±0.05	4.00±0.10	4.00±0.10	2.00±0.05	1.50+0.1,-0	1.2 ⁺⁰
RT-12	3.5±0.10	6.7±0.10	12.0±0.30	1.75±0.10	5.5±0.05	4.00±0.10	4.00±0.10	2.00±0.05	1.50+0.1,-0	1.2 ⁺⁰

Recommend Land Pattern

Unit: mm

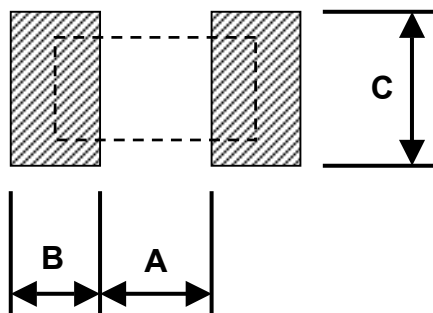

Type	A	B	C
RT-02	0.50	0.45	0.60
RT-03	0.90	0.60	0.90
RT-05	1.20	0.70	1.30
RT-06	2.00	0.90	1.60
RT-10	2.00	0.90	2.80
RT-0A	3.80	0.90	2.80
RT-12	3.80	1.60	3.50