

150mA USB-Compatible Lithium Ion Battery Charger CN3051B/CN3052B

General Description:

The CN3051B/CN3052B is a complete constant-current /constant voltage linear charger for single cell Li-ion and Li Polymer rechargeable batteries. The device contains an on-chip power MOSFET and eliminates the need for the external sense resistor and blocking diode. Furthermore, the CN3051B/CN3052B is specifically designed to work within USB power specifications. Its low external component count makes CN3051B/CN3052B ideally suited for portable applications.

Thermal feedback regulates the charge current to limit the die temperature during high power operation or high ambient temperature. The regulation voltage is fixed at 4.1V(CN3051B) or 4.2V(CN3052B) with 1% accuracy. The charge current can be programmed externally with a single resistor. When the input supply (wall adapter or USB supply) is removed, the CN3051B/CN3052B automatically enters a low power sleep mode , dropping the battery drain current to less than 3uA. Other features include undervoltage lockout, automatic recharge, chip enable function, battery temperature sensing and a $\overline{\text{CHRG}}$ pin to indicate charge status.

The CN3051B/CN3052B is available in 8-pin MSOP package(MSOP8).

Applications:

- MP3 Players
- Bluetooth Applications
- Toys
- USB Bus-Powered Chargers

Features:

- Charges Single Cell Li-Ion Batteries Directly from USB Port or AC Adaptor
- On-chip Power MOSFET
- No external Blocking Diode or Current Sense Resistors Required
- Preset 4.1V or 4.2V Regulation Voltage with 1% Accuracy
- Precharge Conditioning for Reviving Deeply Discharged Cells and Minimizing Heat Dissipation During Initial Stage of Charge
- Programmable Charge Current Up to 150mA
- Constant-Current/Constant-Voltage Operation with Thermal Regulation to Maximize Charge Rate Without Risk of Overheating
- Automatic Low-Power Sleep Mode When Input Supply Voltage is Removed
- Status Indication for LEDs or uP Interface
- C/10 Charge Termination
- Automatic Recharge
- Battery Temperature Sensing
- Chip Enable Input
- Available in MSOP8 Package
- Pb-free Available

Pin Assignment

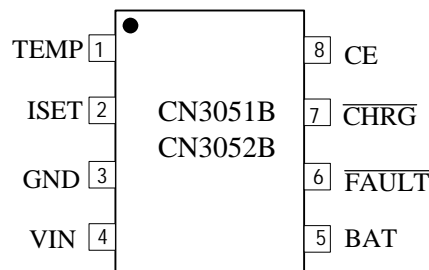

Typical Application Circuit

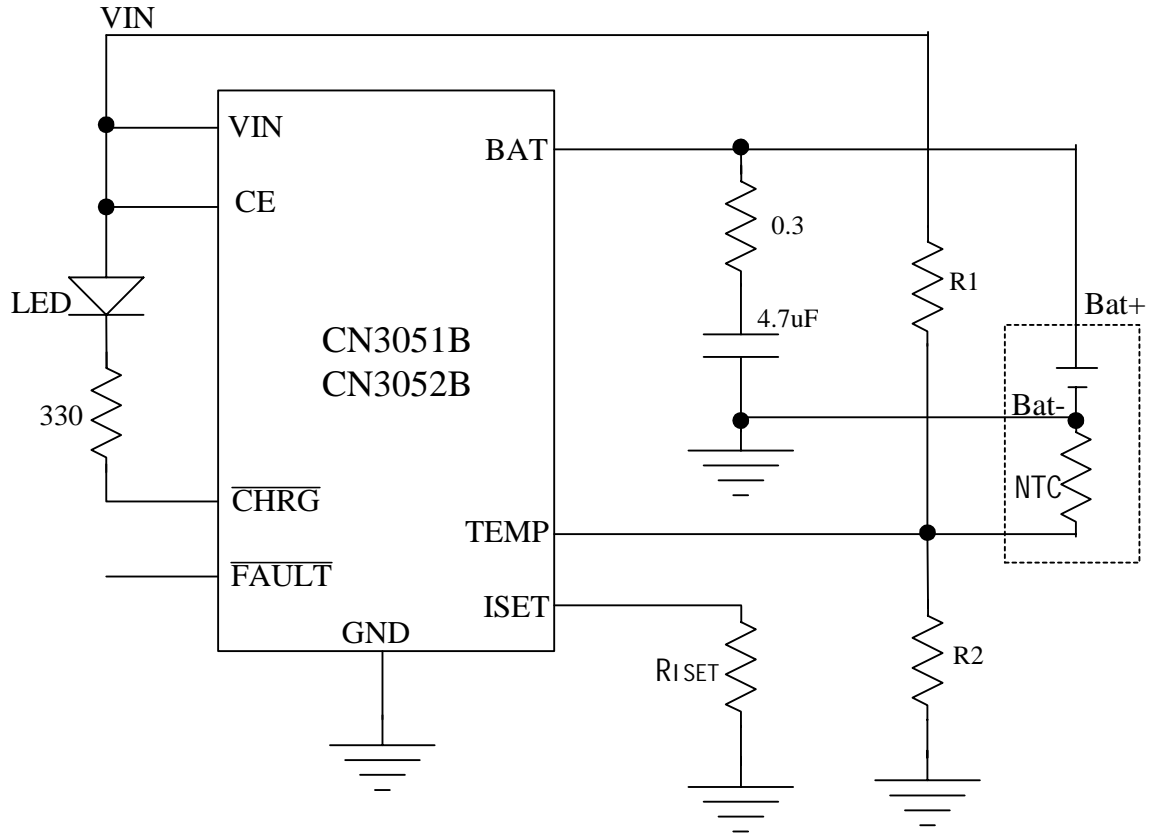

Figure 1 Typical Application Circuit

Ordering Information

Part Number	Regulation Voltage	Package	Operating Ambient Temperature
CN3051B	4.1V	MSOP8	- 40 to 85
CN3052B	4.2V	MSOP8	- 40 to 85

Block Diagram

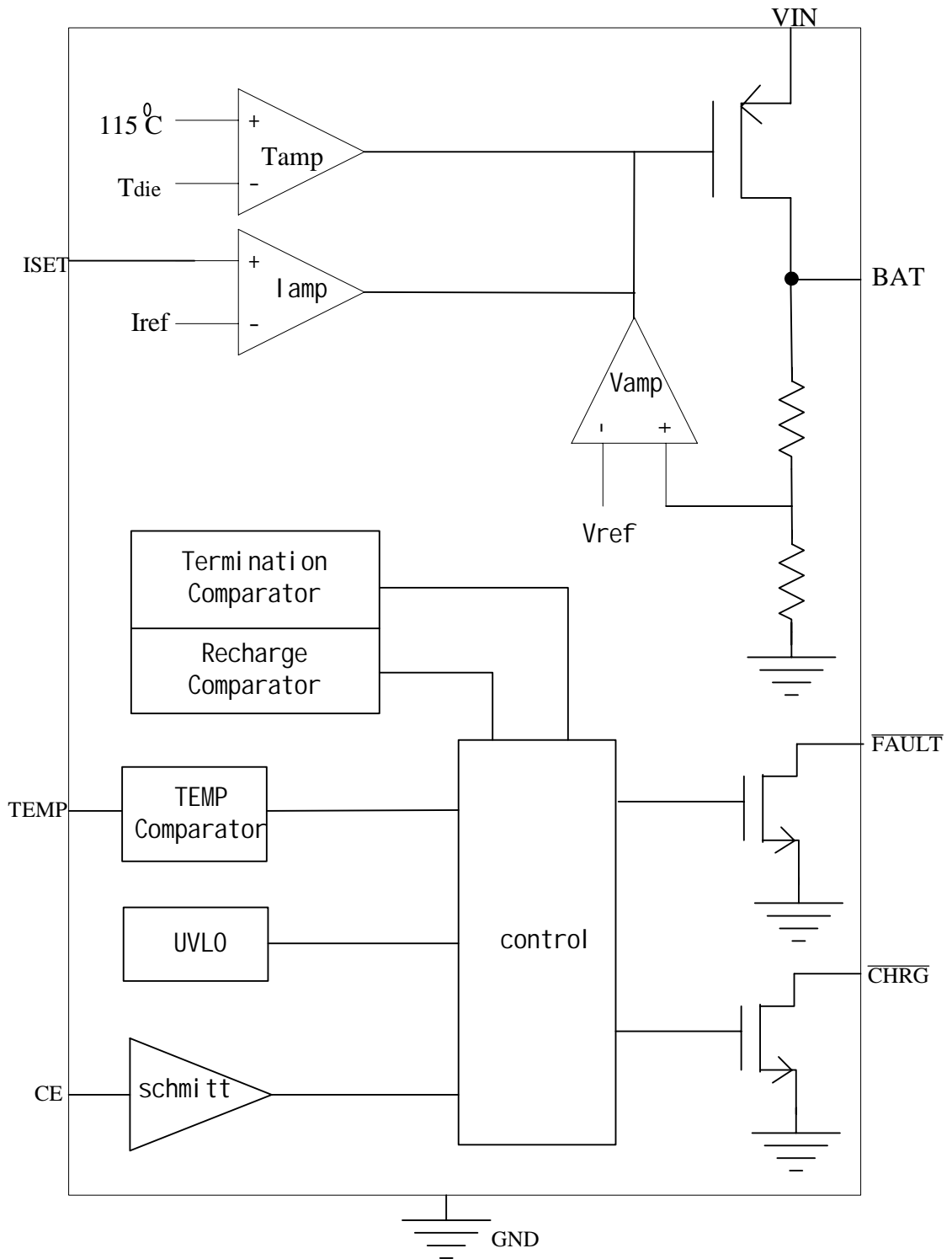

Figure 2 Block Diagram

Pin Description

Pin No.	Name	Function Description
1	TEMP	Temperature Sense Input. Connecting TEMP pin to NTC thermistor's output in Lithium ion battery pack. If TEMP pin's voltage is below 45% or above 80% of supply voltage V_{IN} for more than 0.15S, this means that battery's temperature is too high or too low, charging is suspended, and \overline{FAULT} pin is pulled low to indicate a battery fault state. If TEMP's voltage level is between 45% and 80% of supply voltage for more than 0.15S, battery fault state is released, \overline{FAULT} pin is in high impedance state, and charging will resume. The temperature sense function can be disabled by grounding the TEMP pin.
2	ISET	Constant Charge Current Setting and Charge Current Monitor Pin. The charge current is set by connecting a resistor R_{ISET} from this pin to GND. When in precharge mode, the ISET pin's voltage is regulated to 0.2V. When in constant charge current mode, the ISET pin's voltage is regulated to 2V. In all modes during charging, the voltage on ISET pin can be used to measure the charge current as follows: $I_{CH} = (V_{ISET} / R_{ISET}) \times 925$ R_{ISET} 's value can not be less than 8K
3	GND	Ground Terminal.
4	VIN	Positive Input Supply Voltage. V_{IN} is the power supply to the internal circuit. When V_{IN} drops to within 40mv of the BAT pin voltage, CN3051B/CN3052B enters low power sleep mode, dropping BAT pin's current to less than 3uA.
5	BAT	Battery Connection Pin. Connect the positive terminal of the battery to BAT pin. BAT pin draws less than 3uA current in chip disable mode or in sleep mode. BAT pin provides charge current to the battery and provides regulation voltage of 4.1V(CN3051B) or 4.2V(CN3052B).
6	\overline{FAULT}	Open-Drain Fault Status Output. When the voltage at TEMP pin is below 45% of V_{IN} or above 80% of V_{IN} , this means that battery's temperature is too high or too low, \overline{FAULT} is pulled low by an internal switch to indicate a battery fault state; Otherwise \overline{FAULT} pin is in high impedance state.
7	\overline{CHRG}	Open Drain Charge Status Output. When the battery is being charged, the \overline{CHRG} pin is pulled low by an internal switch, otherwise \overline{CHRG} pin is in high impedance state.
8	CE	Chip Enable Input. A high input will put the device in the normal operating mode. Pulling the CE pin to low level will put the CN3051B/CN3052B into disable mode. The CE pin can be driven by TTL or CMOS logic level.

Absolute Maximum Ratings

All Terminal Voltage.....	- 0.3V to 6.5V	Maximum Junction Temperature.....	150
BAT Short-Circuit Duration.....	Continuous	Operating Temperature.....	- 40 to 85
ESD Rating(HBM).....	2KV	Storage Temperature.....	- 65 to 150
Thermal Resistance (MSOP8)....	TBD	Lead Temperature(Soldering).....	300

Stresses beyond those listed under 'Absolute Maximum Ratings' may cause permanent damage to the device. These are stress ratings only and functional operation of the device at these or any other conditions above those indicated in the operational sections of the specifications is not implied. Exposure to Absolute Maximum Rating Conditions for extended periods may affect device reliability.

Electrical Characteristics

(VIN=5V, TA= - 40 to 85 , Typical Values are measured at TA=25 , unless otherwise noted)

Parameters	Symbol	Test Conditions	Min	Typ	Max	Unit
Input Supply Voltage	VIN		4.35		6	V
Operating Current	IVIN	CE=VIN, No load at BAT pin	400	650	950	uA
		Chip disable mode, CE=GND		4		
Undervoltage Lockout	Vuvlo	VIN rising	3.9	4.03	4.16	V
Undervoltage Lockout Hysteresis	Huvlo			0.1		V
Regulation Voltage	VREG	CN3051B, No load at BAT pin	4.059	4.1	4.141	V
		CN3052B, No load at BAT pin	4.158	4.2	4.242	
BAT pin Current	IBAT	RISET=12.3K, constant current mode, CN3051B/CN3052B		150		mA
		RISET=12.3K, VBAT<VPRE CN3051B/CN3052B	11	15	19	
		VBAT=VREG, standby mode	1.75	3.5	7	uA
		CE=GND, disable mode			3	
		VIN=0V, sleep mode			3	
Precharge Threshold						
Precharge Threshold	VPRE	Voltage at BAT pin rising	2.9	3.0	3.1	V
Precharge Threshold Hysteresis	HPRE			0.1		V
Charge Termination Threshold						
Charge Termination Threshold	Vterm	Measure voltage at ISET pin	0.18	0.22	0.26	V
Recharge Threshold						
Recharge Threshold	VRECH			VREG - 0.1		V
Sleep Mode						
Sleep Mode Threshold	VSLP	VIN from high to low, measures the voltage (VIN - VBAT)		40		mv
Sleep mode Release Threshold	VSLPR	VIN from low to high, measures the voltage (VIN - VBAT)		90		mv
ISET Pin						
ISET Pin Voltage	VISET	Precharge mode		0.2		V
		Constant current mode		2.0		
TEMP PIN						
High Input Threshold				80	82.5	%VIN
Low Input Threshold			42.5	45		%VIN
TEMP input Current		TEMP to VIN or to GND			50	nA
CE Pin						
Logic Input Low	VCEL	CE voltage falling, Chip disabled			0.75	V
Logic Input High	VCEH	CE voltage rising, Chip enabled	2.0			V
CE Pin Current	ICEL	CE=GND, VIN=6V	- 1			uA
	ICEH	CE=VIN=6V			1	

Electrical Characteristics(Continued from last page)

Parameters	Symbol	Test Conditions	Min	Typ	Max	Unit
$\overline{\text{CHRG}}$ Pin						
$\overline{\text{CHRG}}$ Pin Sink Current	I_{CHRG}	$V_{\text{CHRG}}=0.4\text{V}$, charge mode		20		mA
$\overline{\text{CHRG}}$ Leakage Current		$\text{CE}=\text{GND}$, $V_{\text{CHRG}}=6\text{V}$			1	uA
$\overline{\text{FAULT}}$ Pin						
$\overline{\text{FAULT}}$ Pin Sink Current	I_{FAULT}	$V_{\text{FAULT}}=0.4\text{V}$, Fault status		20		mA
$\overline{\text{FAULT}}$ Pin Leakage Current		$\text{CE}=\text{GND}$, $V_{\text{FAULT}}=6\text{V}$			1	uA

Detailed Description

The CN3051B/CN3052B is a linear battery charger designed primarily for charging single cell lithium-ion or lithium-polymer batteries. Featuring an internal P-channel power MOSFET, the charger uses a constant-current/constant-voltage to charge the batteries. Charge current can be programmed up to 150mA with an external resistor. No blocking diode or sense resistor is required. The open-drain output $\overline{\text{CHRG}}$ and $\overline{\text{FAULT}}$ indicates the charger's status. The internal thermal regulation circuit reduces the programmed charge current if the die temperature attempts to rise above a preset value of approximately 115 °C. This feature protects the CN3051B/CN3052B from excessive temperature, and allows the user to push the limits of the power handling capability of a given circuit board without risk of damaging the CN3051B/CN3052B or the external components. Another benefit of adopting thermal regulation is that charge current can be set according to typical, not worst-case, ambient temperatures for a given application with the assurance that the charger will automatically reduce the current in worst-case conditions.

The charge cycle begins when the voltage at the V_{IN} pin rises above the UVLO level, a current set resistor is connected from the ISET pin to ground, and the CE pin is pulled above the chip enable threshold. The $\overline{\text{CHRG}}$ pin outputs a logic low to indicate that the charge cycle is ongoing. At the beginning of the charge cycle, if the battery voltage is below 3V, the charger is in precharge mode to bring the cell voltage up to a safe level for charging. The charger goes into the fast charge constant-current mode once the voltage on the BAT pin rises above 3V. In constant current mode, the charge current is set by R_{ISET} . When the battery approaches the regulation voltage, the charge current begins to decrease as the CN3051B/CN3052B enters the constant-voltage mode. When the current drops to charge termination threshold, the charge cycle is terminated, and $\overline{\text{CHRG}}$ pin assumes a high impedance state to indicate that the charge cycle is terminated. The charge termination threshold is 10% of the current in constant current mode. To restart the charge cycle, remove the input voltage and reapply it, or momentarily force CE pin to 0V. The charge cycle can also be automatically restarted if the BAT pin voltage falls below the recharge threshold. The on-chip reference voltage, error amplifier and the resistor divider provide regulation voltage with 1% accuracy which can meet the requirement of lithium-ion and lithium polymer batteries. When the input voltage is not present, the charger goes into a sleep mode, dropping battery drain current to less than 3uA. This greatly reduces the current drain on the battery and increases the standby time. The charger can be shutdown by forcing the CE pin to GND.

Application Information

Undervoltage Lockout (UVLO)

An internal undervoltage lockout circuit monitors the input voltage and keeps the charger in shutdown mode until V_{IN} rises above the undervoltage lockout voltage(4.0V typical). The UVLO circuit has a built-in hysteresis of 0.1V.

Sleep mode

There is an on-chip sleep comparator. The comparator keeps the charger in sleep mode if V_{IN} falls below sleep mode threshold($V_{BAT}+40\text{mv}$). Once in sleep mode, the charger will not come out of sleep mode until V_{IN} rises 90mv above the battery voltage.

Precharge mode

At the beginning of a charge cycle, if the battery voltage is below 3V, the charger goes into precharge mode , and the charge current is 10% of fast charge current in constant current mode.

Chip Enable/Disable

The CN3051B/CN3052B can be disabled by pulling the CE pin to less than 0.75V. For normal operation, pull the CE pin above 2.0V. Applying a voltage between 0.75V to 2.0V to this pin may cause larger operating current, and the CN3051B/CN3052B may be in uncertain state. When the chip is disabled, the internal linear regulator and the power MOSFET are turned off.

Programming Charge Current

The formula for the battery charge current in constant current mode is:

$$I_{CH} = 1850V / R_{ISET}$$

Where:

I_{CH} is the charge current in ampere

R_{ISET} is the total resistance from the ISET pin to ground in ohm, R_{ISET} 's value can not be less than 8K .

For example, if 100mA charge current is required, calculate:

$$R_{ISET} = 1850V/0.1A = 18.5k$$

For best stability over temperature and time, 1% metal film resistors are recommended. If the charger is in constant-temperature or constant voltage mode, the charge current can be monitored by measuring the ISET pin voltage, and the charge current is calculated as the following equation:

$$I_{CH} = (V_{ISET} / R_{ISET}) \times 925$$

USB and Wall Adapter Power

Although the CN3051B/CN3052B allows charging from a USB port, a wall adapter can also be used to charge Li-Ion/Li-polymer batteries. Figure 3 shows an example of how to combine wall adapter and USB power inputs. A P-channel MOSFET, M1, is used to prevent back conducting into the USB port when a wall adapter is present and Schottky diode, D1, is used to prevent USB power loss through the 1k pull-down resistor.

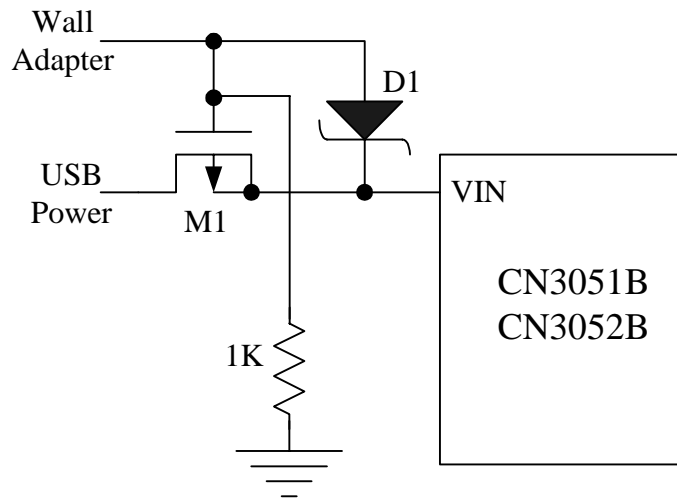

Figure 3 Combining Wall Adapter and USB Power

Battery Temperature Sense

To prevent the damage caused by the very high or very low temperature done to the battery pack, the CN3051B/CN3052B continuously senses battery pack temperature by measuring the voltage at TEMP pin determined by the voltage divider circuit and the battery's internal NTC thermistor as shown in Figure 1.

The CN3051B/CN3052B compares the voltage at TEMP pin (V_{TEMP}) against its internal V_{LOW} and V_{HIGH} thresholds to determine if charging is allowed. In CN3051B/CN3052B, V_{LOW} is fixed at $(45\% \times V_{IN})$, while V_{HIGH} is fixed at $(80\% \times V_{IN})$. If $V_{TEMP} < V_{LOW}$ or $V_{TEMP} > V_{HIGH}$ for 0.15 seconds, it indicates that the battery temperature is too high or too low and the charge cycle is suspended. When V_{TEMP} is between V_{LOW} and V_{HIGH} for more than 0.15 seconds, the charge cycle resumes.

The battery temperature sense function can be disabled by connecting TEMP pin to GND.

Recharge

After a charge cycle has terminated, if the battery voltage drops below the recharge threshold (4.0V for CN3051B, 4.1V for CN3052B), a new charge cycle will begin automatically.

Constant-Current/Constant-Voltage/Constant-Temperature

The CN3051B/CN3052B use a unique architecture to charge a battery in a constant-current, constant-voltage, constant temperature fashion as shown in Figure 2. Amplifiers I_{amp} , V_{amp} , and T_{amp} are used in three separate feedback loops to force the charger into constant-current, constant-voltage, or constant-temperature mode, respectively. In constant current mode the charge current delivered to the battery equal to $1850V/R_{ISET}$. If the power dissipation of the CN3051B/CN3052B results in the junction temperature approaching $115^\circ C$, the amplifier T_{amp} will begin decreasing the charge current to limit the die temperature to approximately $115^\circ C$. As the battery voltage rises, the CN3051B/CN3052B either returns to constant-current mode or it enters constant voltage mode straight from constant-temperature mode.

Open-Drain Status Outputs

The CN3051B/CN3052B have 2 open-drain status outputs: \overline{CHRG} and \overline{FAULT} . \overline{CHRG} is pulled low when the charger is in charging status, otherwise \overline{CHRG} becomes high impedance. \overline{FAULT} is pulled low if battery pack's temperature is in out of temperature condition for more than 0.15S, otherwise \overline{FAULT} becomes high impedance. When the battery is not present, the charger charges the output capacitor to the regulation voltage quickly, then the BAT pin's voltage decays slowly to recharge threshold because of low leakage current at BAT pin, which results in a 100mv ripple waveform at BAT pin, in the meantime, \overline{CHRG} pin outputs a pulse to indicate that the battery's absence. The pulse's frequency is around 10Hz when a 4.7uF output capacitor is used.

The open drain status output that is not used should be tied to ground.

V_{IN} Bypass Capacitor C_{IN}

Many types of capacitors can be used for input bypassing, C_{IN} is typically a 4.7uF capacitor.

Stability

Typically a 4.7uF capacitor in series with a 5% 0.3 resistor from BAT pin to GND is required to stabilize the feedback loop.

In constant current mode, the stability is also affected by the impedance at the ISET pin . With no additional capacitance on the ISET pin, the loop is stable with current set resistors values as high as 50K . However, additional capacitance on ISET pin reduces the maximum allowed current set resistor. The pole frequency at ISET pin should be kept above 200KHz. Therefore, if ISET pin is loaded with a capacitance C, the following equation should be used to calculate the maximum resistance value for R_{ISET}:

$$R_{ISET} < 1 / (6.28 \times 2 \times 10^5 \times C)$$

In order to measure average charge current or isolate capacitive load from ISET pin, a simple RC filter can be used on ISET pin as shown in Figure 4.

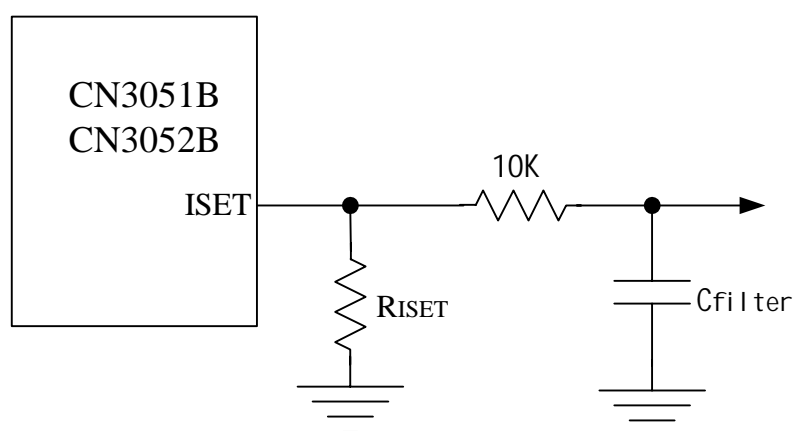
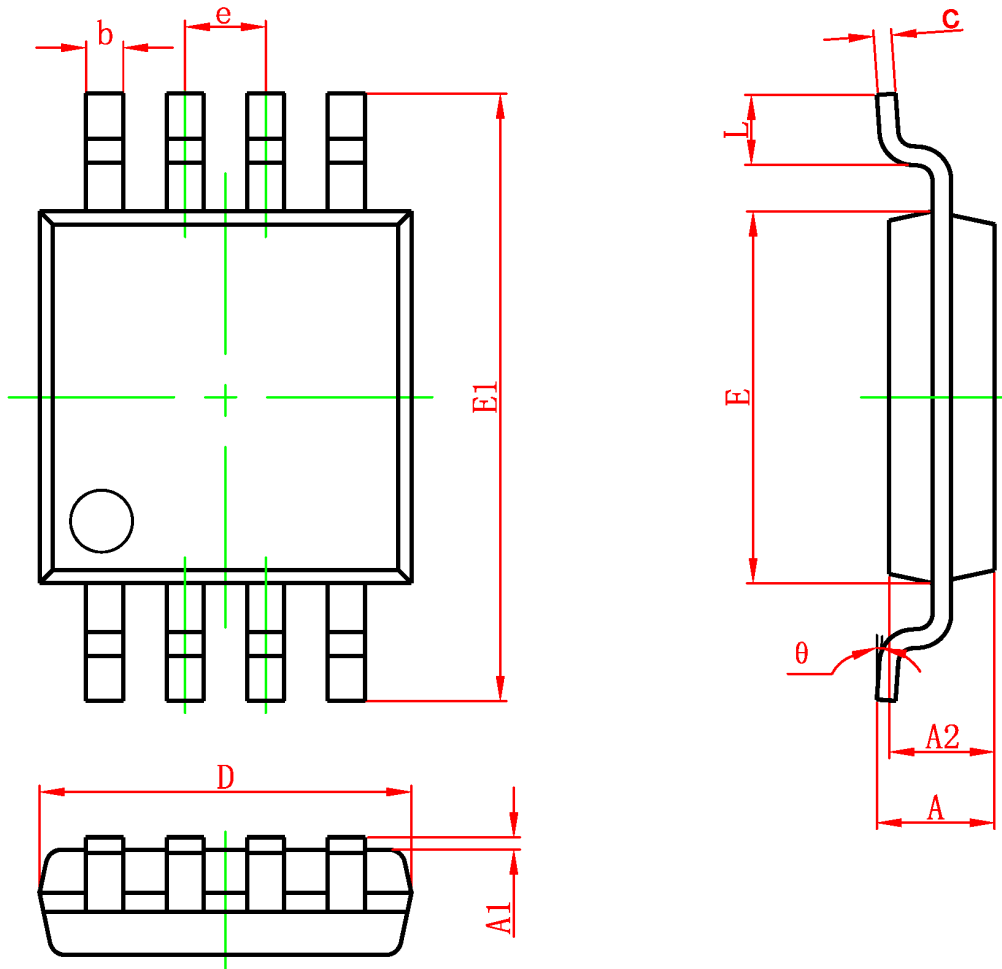

Figure 4 Isolating Capacitive Load on ISET Pin

Board Layout Considerations

Because of the small size of the MSOP8 package, it is very important to use a good thermal PC board layout to maximize the available charge current. The thermal path for the heat generated by the IC is from the die to the copper lead frame, through the package leads, (especially the ground lead) to the PC board copper. The PC board copper is the heat sink. The footprint copper pads should be as wide as possible and expand out to larger copper areas to spread and dissipate the heat to the surrounding ambient. Feedthrough vias to inner or backside copper layers are also useful in improving the overall thermal performance of the charger. Other heat sources on the board, not related to the charger, must also be considered when designing a PC board layout because they will affect overall temperature rise and the maximum charge current.

Package Information(MSOP8)



Symbol	Dimensions In Millimeters		Dimensions In Inches	
	Min	Max	Min	Max
A	0.820	1.100	0.032	0.043
A1	0.020	0.150	0.001	0.006
A2	0.750	0.950	0.030	0.037
b	0.250	0.380	0.010	0.015
c	0.090	0.230	0.004	0.009
D	2.900	3.100	0.114	0.122
e	0.650(BSC)		0.026(BSC)	
E	2.900	3.100	0.114	0.122
E1	4.750	5.050	0.187	0.199
L	0.400	0.800	0.016	0.031
θ	0°	6°	0°	6°