

CL - 203

The CL - 203 is a high - power GaAlAs IRED, with precision optical designed lens. It emits parallel infrared lights.

FEATURES

- Parallel rays
- High reliability
- Flat radiation pattern
- Compact

APPLICATIONS

- Encoders
- High performance - linear sensor

DIMENSIONS

(Unit : mm)

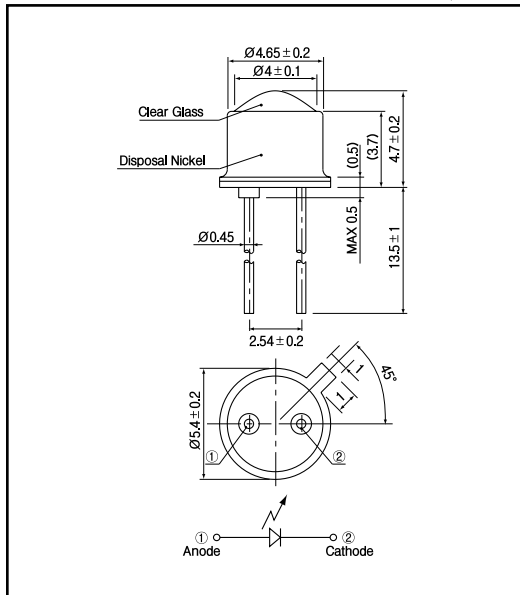

MAXIMUM RATINGS

(Ta=25)

Item	Symbol	Rating	Unit
Reverse voltage	V _R	5	V
Forward current	I _F	80	mA
Pulse forward current	I _{FP}	800	mA
Power dissipation	P _C	160	mW
Operating temp.	T _{opr.}	- 40 - + 100	
Storage temp.	T _{stg.}	- 55 - + 125	
Soldering temp. *1	T _{sol.}	260	

*1. For MAX.5 seconds at the position of 2 mm from the package

ELECTRO-OPTICAL CHARACTERISTICS

(Ta=25)

Item	Symbol	Conditions	Min.	Typ.	Max.	Unit.
Forward voltage	V _F	I _F =50mA		1.4	2.0	V
Reverse current	I _R	V _R =5V			10	μA
Capacitance	C _t	f=1MHz		18		pF
Radiant intensity	P _c	I _F =50mA		2.8		mW/sr
Peak emission wavelength	λ	I _F =50mA		880		nm
Spectral bandwidth 50%		I _F =50mA		50		nm
Half angle					± 9	deg.

Infrared Emitting Diodes(GaAlAs)

CL - 203

Power dissipation Vs. Ambient temperature

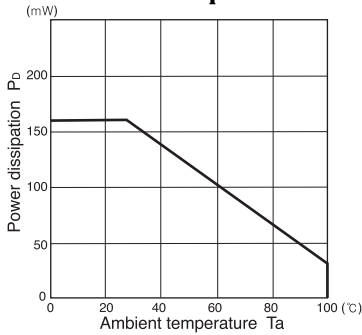

Radiant intensity Vs. Forward current

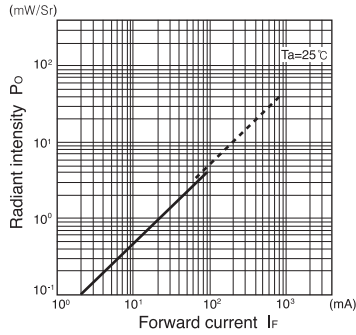

Relative radiant intensity Vs. Ambient temperature

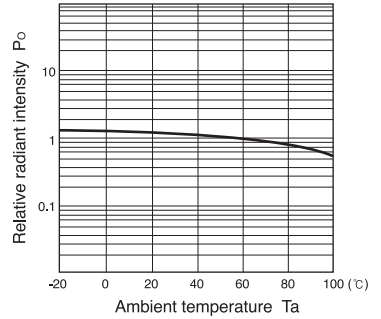

Relative intensity Vs. Wavelength

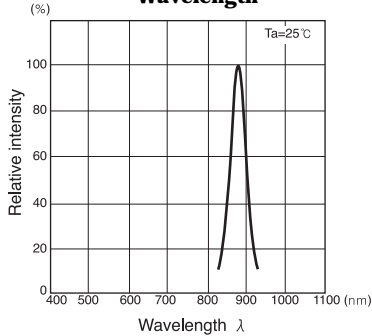

Forward current Vs. Forward voltage

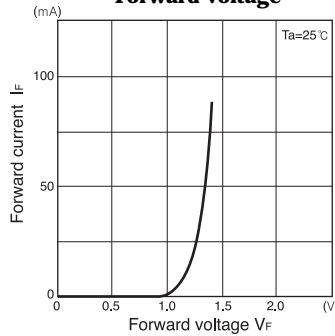

RADIATION PATTERN

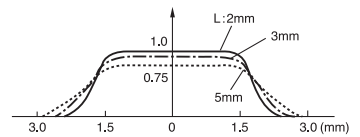

Relative radiant intensity Vs. Distance

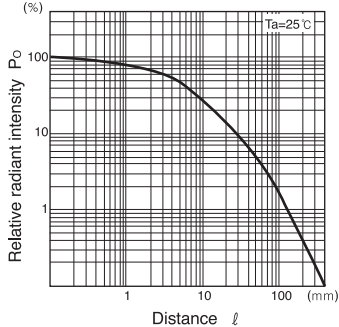

Relative radiant intensity Vs. Distance test method

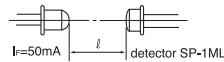

Radiation pattern test method

