

Model No.	POS.1	POS.2
PAL6	OFF	ON
Term. Comm.	OPEN	1-3
SCHEMATIC		

SWITCH FUNCTION

PART NO.	PART NAME	Q'TY
1 MNU-PA01	M12 X 0.75 NUTS	1
2 MNU-1M09	LOCKING WASHER	1
3 MCP-P005	SPLASH PROOF O-RING	1

FILE NAME: HARDWARE-0012

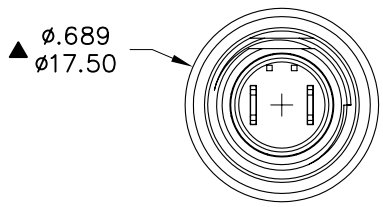

SPECIFICATIONS

Max. current/voltage rating with resistive load: 400mA 24VDC
INITIAL CONTACT RESISTANCE: 100 mΩ max.
INSULATION RESISTANCE: 1 GΩ min. at 500VDC.
DIELECTRIC STRENGTH: 1,000 VAC rms.
ELECTRICAL LIFE AT FULL LOAD: 200,000 cycles.
 OPERATING TEMPERATURE: -30 to 85
PANEL THICKNESS:
 Series: 1.5 mm (.059) min. -5.5 mm (.217) max.
TOTAL TRAVEL: 2.5 mm (.098).
OPERATING FORCE: 4.5N~6.5N.
CONTACT BOUNCE: 10 ms.
 (B) **TORQUE:** 0.5 Nm max. applied to nut.
SOLDERING: 350°C max. for 5 seconds.

PA WITH LED ELECTRO-OPTICAL DATA :

Lens Appearance	Color	Electro-optical Data (AT 20mA)				Viewing Angle 2θ 1/2 (deg)
		Vf(V)		Iv(mcd)		
		Typ.	Max.	Min.	Typ.	
Water Clear	Super Red	2.1	2.6	42.0	100.0	35°
	Super Yellow Green	2.0	2.6	42.0	80.0	
	Super Yellow	2.1	2.6	94.0	200.0	
	Super Blue	2.8	3.2	28.0	70.0	
	Super White	3.5	4.0	140.0	300.0	

MATERIALS

CASE: Glass filled Nylon 6/6(UL94v-0).
CAP: Polyamide 6/6.
BUSHING: Polyamide 6/6.
TERMINAL/CONTACTS: Gold over silver plated.
RoHS: 2002/95/EC

X=CAP COLOR		Y=LED COLOR	
1	White	1	White
2	Black	3	Red
3	Red	5	Yellow
4	Orange	6	Green
5	Yellow	7	Blue
6	Green		
7	Blue		

东莞棠诚电子有限公司
 DongGuan Double Credit Co.,Ltd.

1	符號	原尺寸	修改後尺寸	變更日期	SCALE (比例): 3:2	TITLE 圖名	Sub - Miniature Pushbutton Switches	SIZE 圖紙	A4		
1	(A)		變更版本	MAY - 27 - 2008	TOLERANCE (公差): 0.00 mm ± 0.25mm 0.0 mm ± 0.40mm ANGULAR : ± 5° FILE NAME :	DWG NO. 圖號	PAL6B2M1CESX-5LY	UNIT 單位	inch mm		
2	(B)	1.5Nm max.	0.5Nm max.,增加尺寸標註	FEB - 06 - 2009		REV. 版本	C	DATE 日期	MAY - 21 - 2008	SHEET 張數	1 of 1
3	(C)					CHECKED BY 審核	RICHARD	DRAWN BY 製圖	FION		
4	(D)										
5	(E)										

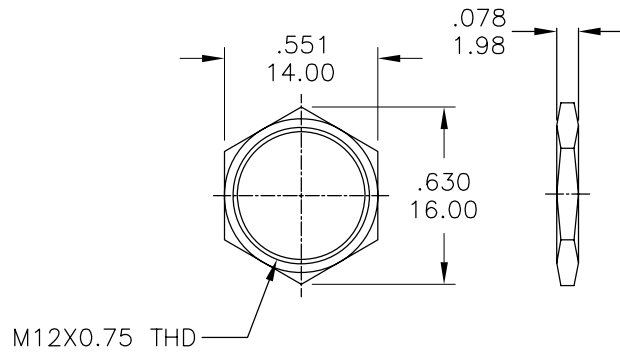

MNU-PA01

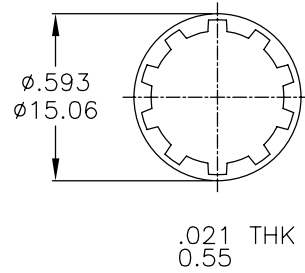

MNU-1M09

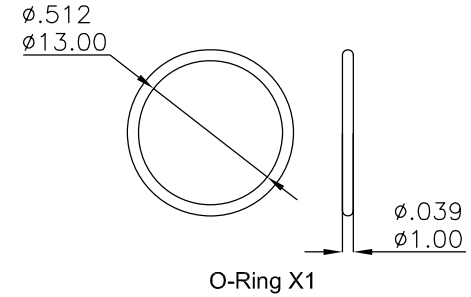

MCP- P005

	PART NO.	PART NAME	Q'TY
1	MNU- PA01	M12 X 0.75 NUTS	1
2	MNU-1M09	LOCKING WASHER	1
3	MCP-P005	SPLASH PROOF O-RING	1

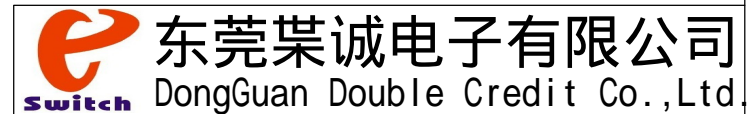

符號	原尺寸	修改後尺寸	變更日期	SCALE (比例): 3:2	TITLE 圖名	HARDWARE		SIZE 圖紙	A4	
1	(A)			TOLERANCE (公差): 0.00 mm \pm 0.25mm 0.0 mm \pm 0.40mm ANGULAR : $\pm 5^\circ$ FILE NAME : HARDWARE-0012	DWG NO. 圖號	M12X0.75 BUSHING PART		UNIT 單位	inch mm	
2	(B)				REV. 版本	A	DATE 日期	MAY - 21 - 2008	SHEET 張數	1 of 1
3	(C)				CHECKED BY 審核	RICHARD		DRAWN BY 製圖	FION	
4	(D)									
5	(E)									