

Reference No. : PD091201001

Customer:

承 認 書

APPROVAL SHEET

零件名稱：積層陶瓷電容

Description : Multi-Layer Chip Capacitor

DATE : 2009/1201

宸遠科技料號 CCT Part Numbers	客戶料號 Customer's Part Numbers

宸 遠 科 技 ChipCera Technology Co., LTD			客 戶 承 認 Customer's Approval
製表 Prepared by	審查 Checked by	核准 Approved by	
Bella		G. Chan	
QA Engineer	QA Manager	Vice G.M.	

深圳市宸远科电子有限公司

ChipCera Technology CO., LTD

深圳市宝安区银田工业区 A9 栋厂房

TEL : +86-755-29120592

FAX : +86-755-29120593

1 Part Number Information

How to order

CC	0805	NP0	8	J	102	R	L
Type CC = Chip Capacitor	Size 0402 0603 0805 1206 1210 1808 1812 2220 1825 2225	Dielectric NP0 X7R Y5V X5R X7E X6S	Dielectric Voltage 2 = 10V 3 = 16V 4 = 25V L=35V 5 = 50V J =63V 6 = 100V 7 = 200V I =400V 9 = 500V H=630V P= 1 KV O=1.2KV R= 2 KV T= 3 KV W=5KV	Tolerance A=±0.05pF B=±0.10pF C=±0.25pF D=±0.50pF F=±1.0% G=±2.0% J=±5.0% K=±10% M=±20% Z=-20~+80%	Capacitance 1st two digits are significant; third digit denotes number of zeros, And A is in place of decimal point. example : 47A=4.7pF 102=10*10 ² pF =1000pF =1nF	Packing Quantity B : Bulk P : 4K/reel 3K/reel R { 2K/reel 1K/reel	RoHS compliance

Tolerance	Capacitance for dielectric				
	NP0		X7R	X5R	Y5V
A=±0.05pF B=±0.10pF C=±0.25pF D=±0.50pF F=±1.0% G=±2.0% J=±5.0% K=±10% M=±20%	10pF and below	More than 10pF	100pF~1 μF (101~105)	1uf~100uf (105~107)	10nF~10uF (103~106)
	B,C,D	G,J	J,K,M	K,M	M,Z

2 Dimension Specification

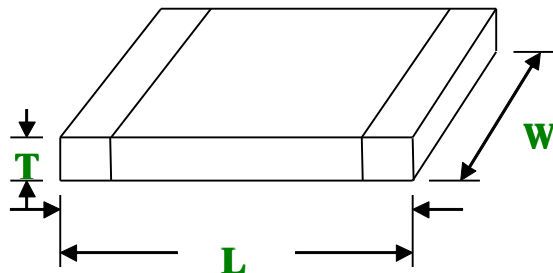
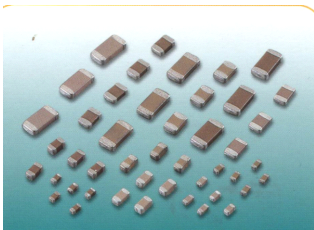

Product dimensions in mm.

Case size	Length(L)	Width(W)	Thickness(T)	Symbol
0402	1.0±0.05	0.50±0.05	0.50±0.05	A
0603	1.6±0.10	0.80±0.10	0.80±0.10	C
0805	2.0±0.10	1.25±0.10	0.60±0.10	B
			0.80±0.10	C
			1.25±0.20	E
1206	3.20±0.15	1.60±0.15	0.80±0.10	C
			1.25±0.20	E
			1.60±0.20	D
1210	3.2±0.15	2.50±0.20	1.25±0.20	E
			1.60±0.20	D
			2.00±0.20	K
			2.40±0.20	G
1808	4.60±0.30	2.00±0.30	1.25±0.20	E
			1.60±0.20	D
			2.00±0.20	K
1812	4.60±0.30	3.20±0.30	1.25±0.20	E
			1.60±0.20	D
			2.00±0.20	K
			2.40±0.20	G
			2.80±0.20	H
2220	5.70±0.40	5.00±0.40	1.25±0.20	E
			1.60±0.20	G
			2.00±0.20	K
			2.40±0.20	G
			2.80±0.20	H
2225	5.70±0.30	6.35±0.40	1.25±0.20	E
			1.60±0.20	D
			2.00±0.20	K
			2.40±0.20	G
			2.80±0.20	H

X7R Series

DIELECTRIC		X7R																																			
SIZE		0402				0603				0805				1206				1210				1808				1812				2220				2225			
CAP	CODE	10V	16V	25V	50V	50V	100V	50V	100V	200V	50V	100V	200V	50V	100V	200V	50V	100V	200V	50V	100V	200V	50V	100V	200V	50V	100V	200V	50V	100V	200V						
180pF	181	A	A	A	A	C	C	C	C	C																											
220pF	221	A	A	A	A	C	C	C	C	C																											
270pF	271	A	A	A	A	C	C	C	C	C	C	C																									
330pF	331	A	A	A	A	C	C	C	C	C	C	C																									
390pF	391	A	A	A	A	C	C	C	C	C	C	C																									
470pF	471	A	A	A	A	C	C	C	C	C	C	C																									
560pF	561	A	A	A	A	C	C	C	C	C	C	C																									
680pF	681	A	A	A	A	C	C	C	C	C	C	C																									
820pF	821	A	A	A	A	C	C	C	C	C	C	C																									
1nF	102	A	A	A	A	C	C	C	C	C	C	C																									
1.2nF	122	A	A	A	A	C	C	C	C	C	C	C																									
1.5nF	152	A	A	A	A	C	C	C	C	C	C	C																									
1.8nF	182	A	A	A	A	C	C	C	C	C	C	C																									
2.2nF	222	A	A	A	A	C	C	C	C	C	C	C																									
2.7nF	272	A	A	A	A	C	C	C	C	C	C	C																									
3.3nF	332	A	A	A	A	C	C	C	C	C	C	C																									
3.9nF	392	A	A	A	A	C	C	C	C	C	C	C	C	E	E	E	E	E	E	E	E	E	E	E	E	E	E	E	E	E							
4.7nF	472	A	A	A	A	C	C	C	C	C	C	C	C	E	E	E	E	E	E	E	E	E	E	E	E	E	E	E	E	E							
5.6nF	562	A	A	A	A	C	C	C	C	C	C	C	C	E	E	E	E	E	E	E	E	E	E	E	E	E	E	E	E	E							
6.8nF	682	A	A	A	A	C	C	C	C	C	C	C	C	E	E	E	E	E	E	E	E	E	E	E	E	E	E	E	E	E							
10nF	103	A	A	A	A	C	C	C	C	C	C	C	C	E	E	E	E	E	E	E	E	E	E	E	E	E	E	E	E	E							
12nF	123	A	A			C	C	C	C	C	C	C	C	E	E	E	E	E	E	E	E	E	E	E	E	E	E	E	E	E							
15nF	153	A	A			C	C	C	C	C	C	C	C	E	E	E	E	E	E	E	E	E	E	E	E	E	E	E	E	E							
18nF	183	A	A			C	C	C	C	C	C	C	C	E	E	E	E	E	E	E	E	E	E	E	E	E	E	E	E	E							
22nF	223	A	A			C	C	C	C	C	C	C	C	E	E	E	E	E	E	E	E	E	E	E	E	E	E	E	E	E							
27nF	273	A	A			C	C	C	C	E	C	C	C	E	E	E	E	E	E	E	E	E	E	E	E	E	E	E	E	E							
33nF	333	A	A			C	C	C	C	E	C	C	C	E	E	E	E	E	E	E	E	E	E	E	E	E	E	E	E	E							
39nF	393	A	A			C	C	C	C	E	C	C	C	E	E	E	E	E	E	E	E	E	E	E	E	E	E	E	E	E							
47nF	473	A	A			C	C	C	C	E	C	C	C	E	E	E	E	E	E	E	E	E	E	E	E	E	E	E	E	E							
56nF	563					C	C	C	C	E	C	C	C	E	E	E	E	E	E	E	E	E	E	E	E	E	E	E	E	E							
68nF	683					C	C	C	C	E	C	C	C	E	E	E	E	E	E	E	E	E	E	E	E	E	E	E	E	E							
100nF	104					C		C	E		C	E	E	E	E	E	E	E	E	E	E	E	E	E	E	E	E	E	E	E							
120nF	124					C		C	E		E	E	E	E	E	E	E	E	E	E	E	E	E	E	E	E	E	E	E	E							
150nF	154					C		C	E		E	E	E	E	E	E	E	E	E	E	E	E	E	E	E	E	E	E	E	E							
180nF	184					C		C	E		E	E	E	E	E	E	E	E	E	E	E	E	E	E	E	E	E	E	E	E							
220nF	224					E		E	E		E	E	E	E	E	E	E	E	E	E	E	E	E	E	E	E	E	E	E	E							
270nF	274							D	E		E	E	E	E	E	E	E	E	E	E	E	E	E	E	E	E	E	E	E	E							
330nF	334							D	E		E	E	E	E	E	E	E	E	E	E	E	E	E	E	E	E	E	E	E	E							
390nF	394							D	E		E	E	E	E	E	E	E	E	E	E	E	E	E	E	E	E	E	E	E	E							
470nF	474							D	E		E	E	E	E	E	E	E	E	E	E	E	E	E	E	E	E	E	E	E	E							
560nF	564										E	E	E	D	D	D	D	D	D	D	D	D	D	D	D	D	D	D	D	D							
680nF	684										E	E	E	D	D	D	D	D	D	D	D	D	D	D	D	D	D	D	D	D							
820nF	824										D	E	D	D	D	D	D	D	D	D	D	D	D	D	D	D	D	D	D	D							
1uF	105										D	D	D	K	G							D	K	D/K	K	K	K	D	K	K							
1.5uF	155										D			G	G							D	K		K	K	K	D	K	K							
2.5uF	225										D			G	G							D	K		K	K	K	D	K	K							
4.7uF	475										D			G	G							D	K		K	K	K	D	K	K							
10uF	106										D			G								D	K		K		D	K	K								

ELECTR		X7R																													
SIZE		0805		1206				1210				1808					1812					2220					2225				
CAP	CODE	250V	500V	250V	500V	1000V	2KV	250V	500V	1KV	2KV	250V	500V	1KV	2KV	3KV	400V	500V	1KV	2KV	3KV	250V	500V	1KV	2KV	3KV	250V	500V	1KV	2KV	3KV
100pF	101																														
120pF	121																														
150pF	151	C	C					E	E							E															
180pF	181	C	C					E	E							E															
220pF	221	C	C					E	E							E															
270pF	271	C	C	C	C			E	E							E															
330pF	331	C	C	C	C			E	E							E															
390pF	391	C	C	C	C			E	E							E															
470pF	471	C	C	C	C			E	E							E															
560pF	561	C	C	C	C			E	E							E															
680pF	681	C	C	C	C			E	E							E															
820pF	821	C	C	C	C			E	E							E															
1nF	102	C	C	C	C			E	E							E															
1.2nF	122	C	C	C	C			E	E							E															
1.5nF	152	C	C	C	C			E	E							E															
1.8nF	182	C	C	C	C			E	E							E															
2.2nF	222	C	C	C	C			E	E							E															
2.7nF	272	C	C	C	C			E	E							E															
3.3nF	332	C	C	C	C			E	E							E															
3.9nF	392	C	C	C	C			E	E							E															
4.7nF	472	C	C	C	C			E	E							E															
5.6nF	562	C	C	C	C			E	E							E															
6.8nF	682	C	C	C	C			E	E							E															
8.2nF	822	C	C	C	C			E	E							E															
10nF	103	C	C	C	C			E	E							E															
12nF	123	C	C	C	C			E	E							E															
15nF	153	C	C	C	C			E																							

X7R/X5R Series

DIELECTRIC		X7R/X5R																															
SIZE		0402				0603				0805				1206				1210				1812				2220							
CAP	CODE	6.3V	10V	10V	25V	35V	50V	6.3V	10V	16V	35V	50V	6.3V	10V	16V	25V	50V	6.3V	16V	25V	35V	50V	6.3V	10V	16V	25V	50V	6.3V	10V	16V	25V	50V	
1uF	105	A		C	C	E	E		C	E	E	E			D	D	D					K					K					K	
1.5uF	155								C	E				E	D	D	D					K					K					K	
2.2uF	225			C	C			C	C	E				E	D	D	D			K	K	K			D	K	K			D	D	K	
3.3uF	335							C	C	E				E	D	D	D			K	K	K			K	K	K			K	K	K	
4.7uF	475			C	C			C	C	E				E	E	D	D	D		K	K	K	K		K	K	K	G		K	K	K	G
10uF	106			C				C	C	E				E	E	D	D	D		K	K	K	G		K	K	K	G		K	K	K	G
22uF	226							C						E	E	D			K	G	G	G		G	G	G	G	G	G	G	G	G	
47uF	476													E	E				K	G				G	G				G	G	G	G	

Y5V Series

DIELECTRIC		Y5V															
SIZE		0402			0603				0805				1206				
CAP	CODE	10V	16V	25V	10V	16V	25V	50V	10V	16V	25V	50V	10V	16V	25V	50V	
10nF	103	A	A	A	C	C	C	C			C	C			C	C	
15nF	153	A	A	A	C	C	C	C			C	C			C	C	
22nF	223	A	A	A	C	C	C	C			C	C			C	C	
33nF	333	A	A		C	C	C	C			C	C			C	C	
47nF	473	A	A		C	C	C	C			C	C			C	C	
68nF	683	A	A		C	C	C	C			C	C			C	C	
100nF	104	A	A		C	C	C	C			C	C			C	C	
150nF	154	A			C	C	C				C	C			C	C	
180nF	184	A			C	C	C				C	C			C	C	
220nF	224	A			C	C	C				C	C			C	C	
330nF	334				C	C	C			C	C			C	C	C	
470nF	474				C	C				C				C	C	C	
680nF	684				C	C			E	C				C	C	C	
820nF	824				C	C			E	C				C	E		
1uF	105				C	C			E	E				C	E		
1.5uF	155								E	E				C	E		
2.2uF	225								E					E	E	E	
3.3uF	335								E					E	E	E	
4.7uF	475								E					E	E	E	
10uF	106								G					E			

4 Specification and Test Method

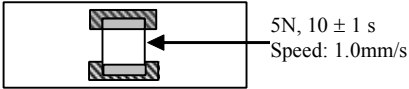
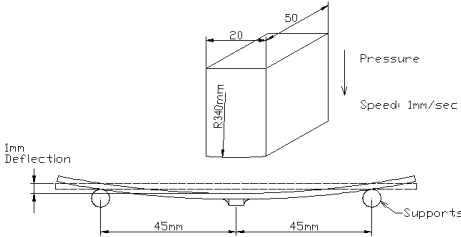
No	Test item	Conditions	Requirements																																
1	Capacitance		Within specified tolerance																																
2	Dissipation Factor (tan δ)	<p>The Capacitance and DF shall be measured at 25°C with HP-4288A</p> <p>NP0 : C ≤ 1000 pF 1±0.2V_{rm}, f = 1 MHz; C > 1000 pF 1±0.2V_{rm}, f = 1 kHz;</p> <p>X5R/ X7R/Y5V : C ≤ 10 μF 1.0±0.2V_{rm} f = @ 1kHz C > 10 μF 0.5±0.2V_{rm} f = @ 120Hz</p>	<p>NP0 :</p> <p>More than 30 pF: Q ≥ 1000 (DF ≤ 0.1%)</p> <p>Less than 30 pF: Q ≥ 400+20 C (Q=1/DF)</p> <p>X7R/X5R :</p> <table border="1" style="width: 100%; border-collapse: collapse;"> <thead> <tr> <th>Rated volt.</th> <th>DF ≤</th> <th colspan="2">Exception of DF ≤</th> </tr> </thead> <tbody> <tr> <td>≥ 50V</td> <td>2.5%</td> <td>3%</td> <td>0603 ≥ 47nF</td> </tr> <tr> <td>25V</td> <td>3.5%</td> <td>—</td> <td>—</td> </tr> <tr> <td>16V</td> <td>3.5%</td> <td>5%</td> <td>0402 ≥ 33nF 0603 ≥ 150nF 0805 ≥ 680nF</td> </tr> <tr> <td>10V</td> <td>5.0%</td> <td>—</td> <td>—</td> </tr> <tr> <td>6.3V</td> <td>7.5%</td> <td>—</td> <td>—</td> </tr> </tbody> </table> <p>Y5V :</p> <table border="1" style="width: 100%; border-collapse: collapse;"> <thead> <tr> <th>Rated volt.</th> <th>DF ≤</th> </tr> </thead> <tbody> <tr> <td>25~250V</td> <td>7%</td> </tr> <tr> <td>16V</td> <td>9%</td> </tr> <tr> <td>10V</td> <td>12.5%</td> </tr> </tbody> </table>	Rated volt.	DF ≤	Exception of DF ≤		≥ 50V	2.5%	3%	0603 ≥ 47nF	25V	3.5%	—	—	16V	3.5%	5%	0402 ≥ 33nF 0603 ≥ 150nF 0805 ≥ 680nF	10V	5.0%	—	—	6.3V	7.5%	—	—	Rated volt.	DF ≤	25~250V	7%	16V	9%	10V	12.5%
Rated volt.	DF ≤	Exception of DF ≤																																	
≥ 50V	2.5%	3%	0603 ≥ 47nF																																
25V	3.5%	—	—																																
16V	3.5%	5%	0402 ≥ 33nF 0603 ≥ 150nF 0805 ≥ 680nF																																
10V	5.0%	—	—																																
6.3V	7.5%	—	—																																
Rated volt.	DF ≤																																		
25~250V	7%																																		
16V	9%																																		
10V	12.5%																																		
3	Insulation resistance	<p>The IR shall be measured with HP-4339B at room temperature.</p> <p>V_r (rated voltage) ≤ 500V At V_r (rated voltage) for 1 minute V_r (rated voltage) > 500V At 500V for 1 minute</p>	RiCr ≥ 500Ω·F, whichever is smaller.																																
4	Dielectric Strength	<p>The withstanding voltage shall be measured with Zentech 9072A.</p> <p>V_r (rated voltage) ≤ 100V At 2.5V_r for 5 seconds V_r (rated voltage) = 200/250V At 1.5V_r+100V for 5 seconds V_r (rated voltage) = 500V At 1.5V_r for 5 seconds V_r (rated voltage) > 500V At 1.2V_r for 5 seconds</p>	<p>No breakdown</p> <p>No flashover</p>																																
5	Adhesion	<p>A force of 5 N shall be applied to the line joining the terminations and in a plane parallel to the substrate time: 10 ± 1 s</p> 	No visible damage																																
6	Bending Strength	<p>Mounting in accordance with IEC 384 10, para 4.4 conditions: bending 1 mm at a rate of 1 mm/s</p> 	<p>No visible damage</p> <p>NPO: ΔC/C within ±5 %</p> <p>X7R/X5R: ΔC/C within ±10 %</p> <p>Y5V: ΔC/C within ±30 %</p>																																

7	Resistance to soldering heat	<p>Preheat the capacitor at 120°C to 150°C for 1 minute. Immerse the capacitor in an eutectic solder solution at 270±5°C for 10±1seconds. After set it at room temperature for 24±2hours (temperature compensation type) or 48±4hours (high dielectric constant type), then measure.</p> <p>*High dielectric constant type : Initial measurement of X7R/X5R and Y5V. Perform a heat treatment at 150±5°C for one hour and then set it at room temperature for 48±4hours. Perform the initial measurement.</p>	<table border="1"> <tr> <td>Dielectric</td> <td>NP0</td> <td>X7R/ X5R</td> <td>Y5V</td> </tr> <tr> <td>Appearance</td> <td colspan="3">No defect</td> </tr> <tr> <td>Capacitance Change</td> <td><±2.5% or <±0.25pF</td> <td>±7.5%</td> <td>±20%</td> </tr> <tr> <td>DF</td> <td colspan="3">The same as No.2</td> </tr> <tr> <td>IR</td> <td colspan="3">More than 500Ω-F (whichever is smaller)</td> </tr> <tr> <td>Dielectric Strength</td> <td colspan="3">No failure</td> </tr> </table>	Dielectric	NP0	X7R/ X5R	Y5V	Appearance	No defect			Capacitance Change	<±2.5% or <±0.25pF	±7.5%	±20%	DF	The same as No.2			IR	More than 500Ω-F (whichever is smaller)			Dielectric Strength	No failure		
			Dielectric	NP0	X7R/ X5R	Y5V																					
Appearance	No defect																										
Capacitance Change	<±2.5% or <±0.25pF	±7.5%	±20%																								
DF	The same as No.2																										
IR	More than 500Ω-F (whichever is smaller)																										
Dielectric Strength	No failure																										
8	Resistance to leaching	The capacitors are dipped into the solder at 260±5°C for 30±1 seconds, and then check the soldering by measuring the areas covered with solder.	95% of the terminations are to be soldered evenly and continuously.																								
9	Solder ability of termination	Zero hour test, and test after storage (20 to 24 months) in original atmosphere in normal atmosphere; un-mounted chips completely immersed for 2 ± 0.5 s in a solder bath of 235 ± 5°C.	95% of the termination is to be soldered evenly and continuously.																								
10	Rapid change of temperature	<p>NPO/X7R: -55°C to +125°C, 5 cycle</p> <p>X5R: -55°C to +85°C, 5 cycle</p> <p>Y5V: -25°C to +85°C, 5 cycle</p> <p>Duration: 30 mins.</p> <p>Recovery: 24 ± 2 hrs.</p>	<p>No visible damage after 24 h recovery</p> <p>Class I NPO: ΔC/C ≤ 2.5 % or ± 0.25 pF</p> <p>Class II X7R/X5R: ΔC/C ≤ ±15 %</p> <p>Y5V: ΔC/C ≤ ±20 %</p>																								
11	Damp heat, steady state	500±12hours at 40±2°C; 90 to 95 % RH	<p>No visible damage after 24 ± 2 (NPO) or 48 ± 4 hours recovery</p> <p>Class I (NPO)</p> <ol style="list-style-type: none"> ΔC/C ± 5 % or 1 pF, whichever is greater C<10pF ; Q ≥ 200+10C 10≤C≤30pF ; Q≥275+5/2C C>30pF ; Q≥350 IR ≥ 4000 MΩ or RiCR ≥ 40ΩF, whichever is less <p>Class II (X7R/X5R)</p> <ol style="list-style-type: none"> ΔC/C within ± 15 % tan δ ≤ 7% R ≥ 2000 MΩ or RiCR ≥ 50ΩF, whichever is less <p>Class II (Y5V)</p> <ol style="list-style-type: none"> ΔC/C within ± 30 % 50/25V: tan δ ≤ 9% 16V: tan δ ≤ 12.5% 10V: tan δ ≤ 15% IR ≥ 2000 MΩ or RiCR ≥ 50ΩF, whichever is less 																								
12	Endurance	<p>1000 h at maximum temperature</p> <p>Vr (rated voltage) ≤ 250V At 2×Vr Vr (rated voltage) = 500V At 1.5Vr Vr (rated voltage) > 500V At 1.2Vr C>0..1UF,At1.5Vr</p>	<p>No visible damage after 24 ± 2 (NPO) or 48 ± 4 hours recovery</p> <p>Class 1 (NPO)</p> <ol style="list-style-type: none"> ΔC/C ± 2 % or 1 pF, whichever is greater tan δ ≤ 2 x specified value IR ≥ 4000 MΩ or RiCR ≥ 40ΩF, whichever is less <p>Class 2 (X7R/X5R)</p> <ol style="list-style-type: none"> ΔC/C within ± 15 % tan δ ≤ 7% IR ≥ 2000 MΩ or RiCR ≥ 50ΩF, whichever is less <p>Class 2 (Y5V)</p> <ol style="list-style-type: none"> ΔC/C within ± 30 % 50/25V: tan δ ≤ 9% 16V: tan δ ≤ 12.5% IR ≥ 2000 MΩ or RiCR ≥ 50ΩF, whichever is less 																								

Paper Tape $T \leq 1.1$ mm

Embossed Tape $T \leq 2.60$ mm

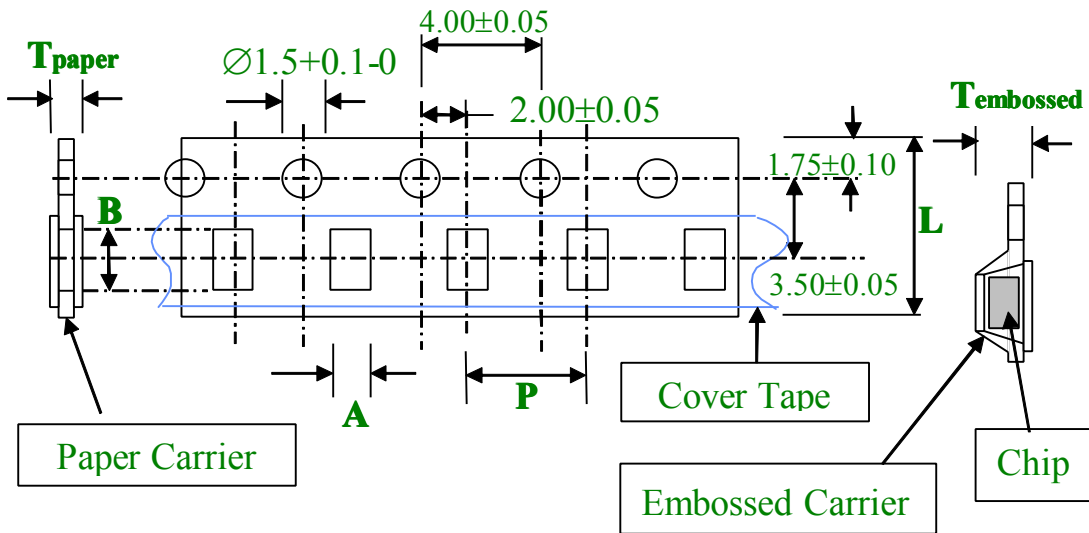

All dimensions in mm

Size	Symbol					
	A	B	P	L	T(Paper)	T(Embossed)
0402	0.62±0.05	1.12±0.05	2.00±0.05	8.00±0.20	0.60±0.05	N/A
0603	1.10±0.10	1.90±0.10	4.00±0.10	8.00±0.20	1.00±0.05	N/A
0805	1.65±0.05	2.40±0.05	4.00±0.10	8.00±0.20	1.00±0.05	N/A
1206	2.00±0.10	3.50±0.10	4.00±0.10	8.00±0.20	1.00±0.05	Max.2.0
1210	2.80±0.20	3.70±0.20	4.00±0.10	8.00±0.20	N/A	Max.2.0
1808	2.50±0.30	4.90±0.30	4.00±0.10	12.0±0.20	N/A	Max.2.5
1812	3.60±0.30	4.90±0.30	8.00±0.10	12.0±0.20	N/A	Max.2.5

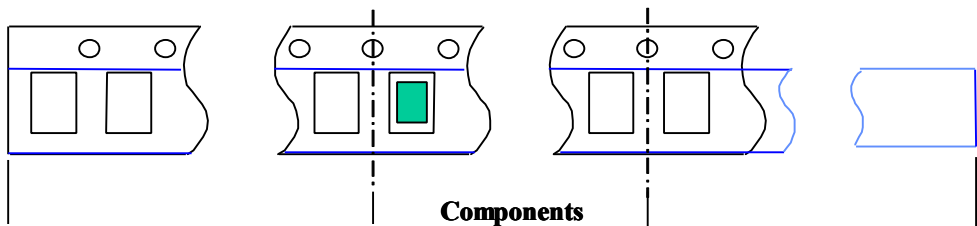

No Components, 180~220 mm
sealed with cover tape

No Components, 220~260 mm

EIA Reel Dimension

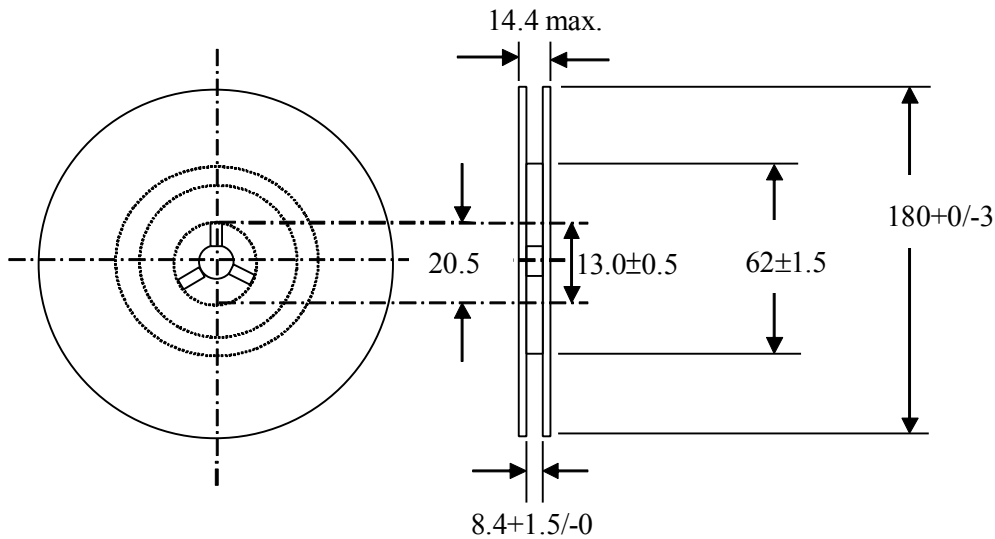

All dimensions in mm

Standard Packing Quantity per Reel

Chip Size	Thickness(mm)	Code	Amount per reel	
			Paper	Embossed
0402	0.50±0.05	A	10K	—
0603	0.80±0.10	C	4K	—
0805	0.60±0.10	B	4K	—
	0.80±0.10	C	4K	—
	1.25±0.20	E	—	2K/3K
1206	0.60±0.10	B	4K	—
	0.80±0.10	C	4K	—
	1.25±0.20	E	—	2K/3K
	1.60±0.20	D	—	2K
1210	1.25±0.20	E	—	2K/3K
	1.60±0.20	D	—	2K
	2.00±0.20	K	—	2K
1808	1.25±0.20	E	—	2K/3K
	1.60±0.20	D	—	2K
	2.00±0.20	K	—	2K
1812/2220/2225	1.25±0.20	E	—	1K
	1.60±0.20	D	—	1K
	2.00±0.20	K	—	1K
	2.40±0.20	G	—	700PCS
	2.80±0.20	H	—	500PCS

6.1 Capacitor Classification

Multi-layer ceramic capacitors are available in wide range of characteristics. Electronic Industries Association (EIA) and the military have established categories to help divide the basic characteristics into more easily specified classes. The basic industry specification for ceramic capacitor is EIA specification RS-198 and as noted in the general section, it specifies temperature-compensating capacitors as class I capacitors. These are specified by the military under specification MIL-C-20. General-purpose capacitors with non-linear temperature coefficients are called Class II capacitors by EIA and specified by military under MIL-C-11015 and MIL-C-39014. The new high reliability military specification, MIL-C-123 covers both class I and class II dielectrics.

Class I — Class I capacitors or temperature-compensating capacitors are usually made from mixtures of titanates where barium titanate is normally not a major part of mix. They have predictable temperature coefficients and in general, do not have an aging characteristic. Thus they are the most stable capacitor available. Normally the T.C.s of Class I temperature-compensating capacitors are NP0 ($\pm 30 \text{ ppm}/^\circ\text{C}$).

Class II — General-purpose ceramic capacitors are called Class II capacitors and have become extremely popular because of the high capacitance values available in very small size. These capacitors are ferroelectrics and vary in capacitance value under the influence of the environmental and electrical operating conditions. Class II capacitors are affected by temperature, voltage, frequency and time. Temperature effects for Class II ceramic capacitors are exhibited as non-linear capacitance changes with temperature. Industry standards for Mid-K dielectrics, such as X7R/X5R and High-K dielectrics, such as Z5U.

6.2 The Characterization of Materials

Designation	Class	Temperature Range ($^\circ\text{C}$)	Temp. Characteristics
NP0(COG)	I	-55 ~ +125	$\pm 30 \text{ ppm}/^\circ\text{C}$
X7R	II	-55 ~ +125	$\pm 15 \%$
X5R	II	-55 ~ +85	$\pm 15 \%$
Y5V	II	-25 ~ +85	-82 ~ +22 %

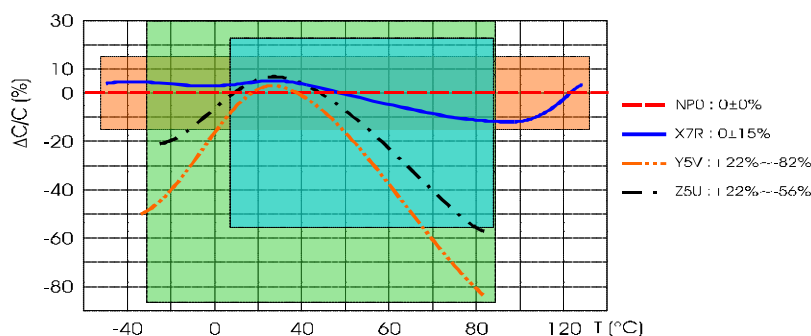

The T.C curve of each material (for reference)

6.3 Recommend IR reflow and wave soldering profile(Pb-Free)

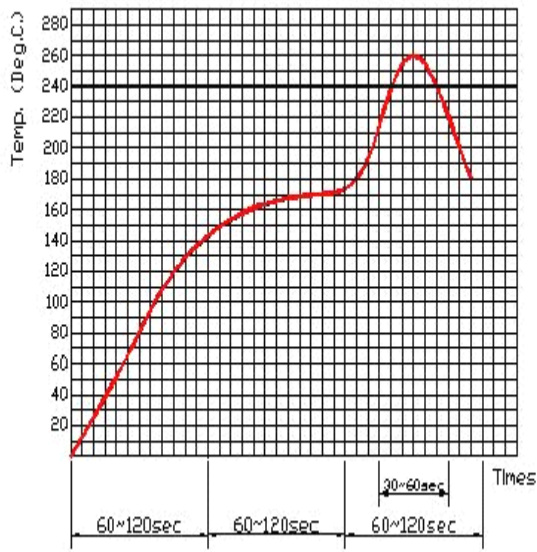

Typical profile band of IR reflow

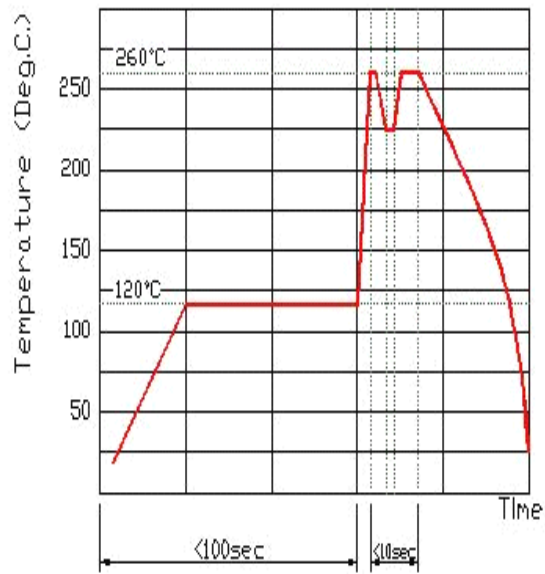

Typical profile band of wave soldering