



Doc. version :	0.2
Total pages :	22
Date :	2004.02.20

Product Specification

1.8" COLOR TFT-LCD MODULE

MODEL NAME: A018AN03 V3

<◆> Preliminary Specification

< > Final Specification

Note: The content of this specification is subject to change.

Contents:

A. Physical specification **P5**

B. Electrical specifications **P6**

 1. Pin assignment **P6**

 a. TFT-LCD panel driving section **P7**

 b. LED Backlight driving section **P8**

 2. Equivalent circuit of I/O **P8**

 3. Absolute maximum ratings **P8**

 4. Electrical characteristics **P9**

 a. Typical operating conditions **P9**

 b. Current consumption **P9**

 c. LED driving conditions **P10**

 5. AC Timing **P10**

 a. Timing conditions **P10**

 b. Timing diagram **P11**

 6. DC-DC converter circuit **P11**

 a. Boost converter **P11**

 b. Shutdown mode **P12**

 c. Oscillator circuit **P12**

C. Optical specifications..... P13

D. Reliability test items..... P15

E. Packing form..... P16

Appendix:

Fig1 DC-DC converter block diagram..... **P10**
Fig2 DCCK block diagram..... **P11**
Fig3.PWM control state diagram..... **P11**
Fig.4 Outline dimension of TFT-LCD module..... **P16**
Fig.5 Input signal timing relationship **P17**
Fig.6 Input vertical timing **P18**
Fig.7 Horizontal input timing..... **P19**
Fig.8 Extraction of display data from memory to Panel..... **P20**
Fig.9 Hsync, Vsync, Data, DCLk relationship..... **P21**
Fig.10 Application circuit..... **P22**

For SAC Internal Use Only

A. Physical specifications

NO.	Item	Specification	Remark
1	Display resolution(dot)	280(W) x220(H)	
2	Active area(mm)	35.6(W) x26.6(H)	
3	Screen size(inch)	1.75(Diagonal)	
4	Dot pitch(mm)	0.127(W) x0.121(H)	
5	Color configuration	R. G. B. delta	
6	Overall dimension(mm)	48.6(W) x39.8(H) x3.9(D)	Note 1
7	Weight(g)	12.7± 2 typ.	
8	Panel surface treatment	Hard coating (3H)	

Note 1: Refer to Fig. 4

For SAC Internal Use Only

B. Electrical specifications

1. Pin assignment

a. TFT-LCD panel driving section

Pin no	Symbol	I/O	Description	Remark
1	GND	-	Ground for gate	
2	V _{CC}	P	Supply voltage of logic control circuit for scan driver	
3	V _{GL}	P	Negative power for scan driver	
4	V _{GH}	P	Positive power for scan driver	
5	FRP	O	Gate driver input signal that is frame polarity output for V _{com}	
6	VCOM	I	Common electrode driving signal	
7	DRV	VO	Power transistor gate signal for the boost converter	
8	GND	-	Ground	
9	FB	VI	Main boost regulator feedback input (FB threshold is 1.2V)	
10	SHL	I	Left/Right scan control input	Note 1
11	STB	I	Stand by mode setting pin.	Note 2
12	V _{CC}	P	Supply voltage for source driver	
13	SHDB	I	Shutdown input. Active low.	Note 3 Note 6
14	AGND	P	Ground pins for analog circuits	
15	VLED	I	LED Anode	
16	GLED	O	LED Cathode	
17	AVDD	P	Power supply for analog circuits	
18	HSYNC	I	Horizontal sync input. Negative polarity	
19	VSYNC	I	Vertical sync input. Negative polarity.	
20	DCLK	I	Clock signal; latch data onto line latches at the rising edge.	
21	D07	I	Data input. :MSB	
22	D06	I	Data input	
23	D05	I	Data input	
24	D04	I	Data input	
25	D03	I	Data input	
26	D02	I	Data input. :LSB	

27	SEL0	I	Select pin for interface definition	Note 4
28	GRB	I	Global reset pin.	Note 5 Note 6
29	U/D	I	Up/Down scan control input	Note 1
30	GND	-	GND for logic circuit	
31	AVDD1	P	Supply of positive power for level shift circuit.	
32	AGND1	P	Ground for level shift circuit	

I: Input; O: Output. VI: voltage input VO: voltage output P:power

Note 1: Selection of scanning mode

Mode	Setting of scan control input		Scanning direction
	U/D	SHL	
			Note 5
Normal mode	L	H	From up to down, and from left to right.
Reverse mode	H	L	From down to up, and from right to left.

Refer to figure as below:

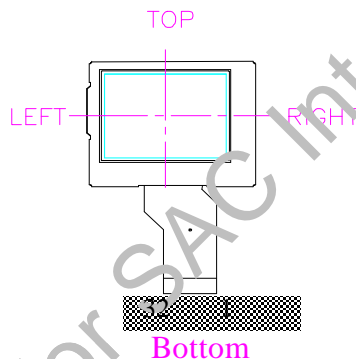

Note 2: Stand by mode(STB).If STB high, it is normal operation.

If it is low, it is standby function. Normally pulled high.

Note 3:Shutdown input(SHDB).Active low, DC-DC converter is off when SHDB is low, Normally pulled low.

Note 4: interface select pin, Pull Low for UPS051 interface.

Note 5:Global reset pin. It should be connected to VCC in normal operation. If Connected to GND, the controller is in reset state, normally pulled high.

Note 6:Be sure to apply GRB to low and SHDB to low first, before turn off DCLK.

Note 7: Definition of scanning direction.

b. LED driving section (Refer to Fig.1)

No.	Symbol	I/O	Description	Remark
Pin15	VLED		LED Anode	
Pin 16	GLED	-	LED Cathode	

2. Equivalent circuit of I/O

Pin no & Pin name	Schematics
7.DRV	
8.FB 9.SHL 10.STB 12.SHDB 17.HSYNC 18.VSYNC 19.DCLK 20.D07 21.D06 22.D05 23.D04 24.D03 25.D02 26.GRB 27.U/D	

3. Absolute maximum ratings

Item	Symbol	Condition	Min.	Max.	Unit	Remark
Power voltage	V_{CC}	GND=0	-0.5	5.	V	
	AV_{DD}	$AV_{SS}=0$	-0.5	5.5	V	
	V_{GH}	GND=0	-0.3	21	V	
	V_{GL}		-17	0.3	V	
	$V_{GH} - V_{GL}$		-	38	V	
Operating temperature	Topa		0	60	°C	Ambient temperature
Storage temperature	Tstg		-25	80	°C	Ambient temperature

4. Electrical characteristics

a. Typical operating conditions (GND=AVss=0V)

Item	Symbol	Min.	Typ.	Max.	Unit	Remark
Power supply	V _{CC}	2.5	3.3	3.6	V	
	AV _{DD}	3.2	3.3	4.5	V	
	AV _{DD1}	4.0	5.6	6.0	V	Note 5
	V _{GH}	14	16	18	V	
	V _{GL_AC}	-	5.6	-	Vp-p	AC component of V _{GL} . Note 1
	V _{GL_H}	-13.5	-11.5	-9.5	V	High level of V _{GL} .
VCOM	V _{CAC}	-	5.6	-	Vp-p	AC component, Note 2
	V _{CDC}	0.1	0.5	0.8	V	DG component, Note 3 Note 4
Output Signal voltage	H Level	V _{OH}	V _{CC} -0.4	V _{CC}	V	
	L Level	V _{OL}	GND	GND+0.4	V	
Input Signal voltage	H Level	V _{IH}	0.7V _{CC}	V _{CC}	V	
	L Level	V _{IL}	GND	0.3V _{CC}	V	
DRV output voltage	V _{DRV}	0		V _{CC}	V	
DRV output	IDRV			10	mA	
Feedback voltage	V _{FB}		1.2	1.25	V	
Output current	H Level	I _{OH}		10	uA	
	L Level	I _{OL}		-10	uA	
Analog stand by current	I _{st}			200	uA	DCLK is stopped
FRP output current	H Level	I _{OHF}		20	mA	For Vcom circuits.
	L Level	I _{OLF}		20	mA	

Note 1: The same phase and amplitude with common electrode driving signal (VCOM).

Note 2: The brightness of LCD panel could be adjusted by the adjustment of the AC component of VCOM.

Note 3: V_{CDC} could be adjusted so as to minimize vertical straight line, flicker and maximum contrast on each module.

Note 4: AV_{DD1} is supply voltage for VCOM swing circuit, this circuit output FRP signal. The voltage will decide VCOM peak to peak value,(and VCOM peak to peak is 5.6V).

Note 5: The applicable pins are SHL, STB, SHDB, HSYNC, VSYNC, DCLK, D05~D00,GRB,U/D :

b. Current consumption (GND=AVss=0V)

Parameter	Symbol	Condition	Min.	Typ.	Max.	Unit	Remark
Current for driver	I _{GH}	V _{GH} =14.7V	-	0.25	1.0	mA	
	I _{GL}	V _{GL_H} =-11V	-	-0.14	-0.8	mA	
	I _{CC}	V _{CC} =3.3V	-	3.0	6	mA	
	I _{DD}	AV _{DD} =3.3V	-	1.5	3	mA	
	I _{DD1}	AV _{DD1} =5.6V	-	0.5	0.7	mA	

c. LED driving conditions

Parameter	Symbol	Min.	Typ.	Max.	Unit	Remark
LED current			20		mA	
LED voltage	V_L			12	V	
LED Life Time	L_L	10000			Hr	Note 1,2

Note 1 : $T_a = 25^\circ\text{C}$, $I_L = 20\text{mA}$

Note 2 : Brightness to be decreased to 50% of the initial value.

5. AC Timing

a. Timing conditions

Parameter		Symbol	Min.	Typ.	Max.	Unit.	Remark
DCLK	Frequency	$1/T_{vc}$	5.37	5.67	6.0	MHz	
	High time	T_{vch}	15			ns	
	Low time	T_{vcl}	15			ns	
Rising time		t_r	-	-	10	ns	Note 1
Falling time		t_f	-	-	10	ns	Note 1
HSYNC	Period	TH	60	63.56	67	us	Note 2
				360		DCLK	
	Display period	THd		49.4		us	
	Pulse width	THp	1	25		DCLK	
HSYNC-Clk timing		THc	15		$T_{vc}-15$	ns	
Hsync setup time		T_{vst}	12			ns	
Hsync hold time		T_{hhd}	12			ns	
Horizontal lines per field		t_v	256	262	268	t_H	
VSYNC	Period	TV		16.6		ms	Note 2
				262		t_H	
	Display period	TVd		13.97		ms	
	Pulse width	TVp	1			DCLK	
				3		TH	
Vsync setup time		T_{vst}	12			ns	
Vsync hold time		T_{vhd}	12			ns	
DATA D00~D05	DCLK-DATA timing	T_{ds}	10	-	-	ns	
	DATA-CLK timing	T_{dh}	10	-	-	ns	
	Rising time Falling time	T_{drf}	-	-	30	ns	

Note 1: For all of the logic signals.

Note 2: Display position

A.. Horizontal display position

The display starts from the data of (57DCLK, $T_{He}=57\text{DCLK}$) as shown in Fig 5.

(The : From Hsync falling edge to 1st displayed data.)

B. Vertical display position

Parameter	Symbol	Min.	Typ.	Max.	Unit	Remark
Vertical display position	TVS		25		TH	NTSC

b. Timing diagram

Please refer to the attached drawing, from Fig.5 to Fig.8.

6. DC-DC Converter Circuit

A018AN03 V3 contains one high-power step-up DC-DC converter, and backplane drive circuitry for active matrix TFT LCDs. The output voltage of the main boost converter can be set from VCC to 13.5V with external resistors. Also included in A018AN03 V3 are a precision 1.2V reference voltage, fault detection and logic shutdown.

a .Boost Converter

A018AN03 V3 main boost converter uses a boost PWM architecture to produce a positive regulated voltage, Please refer to the below figures to see the block diagram.

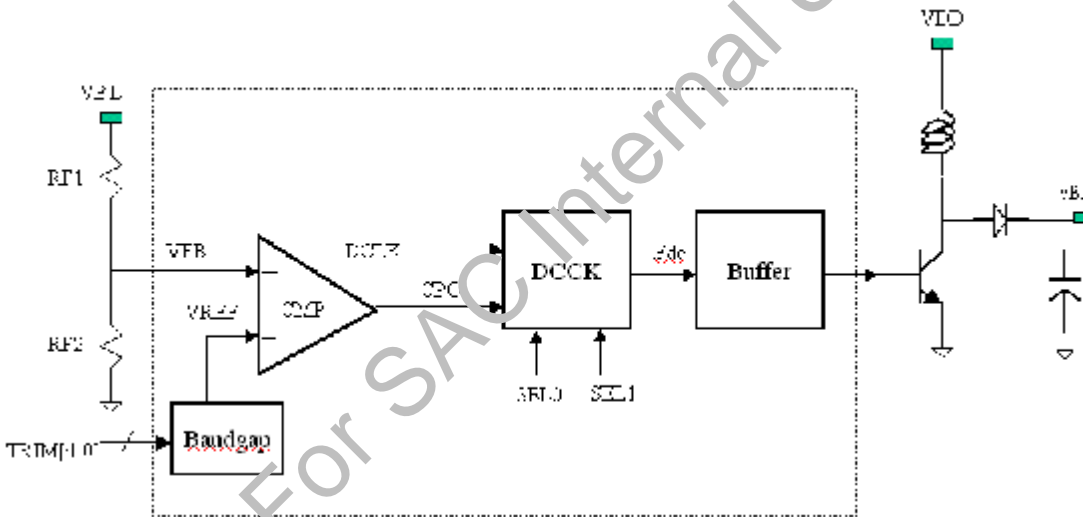

Fig 1 DC-DC converter block diagram

In the internal architecture of DC-DC converter. The feedback voltage(VFB) will connect to the tri-angle waveform comparator ,and generates the output signal (CP0) which determines the duty cycle for (Fdc).

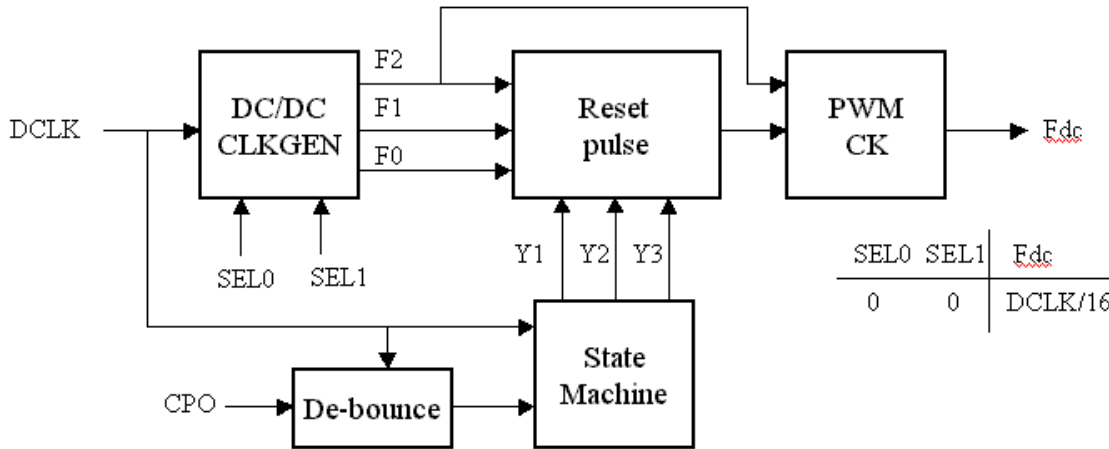

Fig 2 DCCK block diagram

To reduce the noise affect,CP0 will processed by De-bounce circuit. State-machine will generate the duty cycle by CP0 signal. To make sure that VFB can reach default VREF quickly, so State-machine's is designed as a discrete step by step function. please refer to Fig 3. If CP0 is low , Duty cycle will work from 0% to 75%. The maximum duty ratio is 75%.

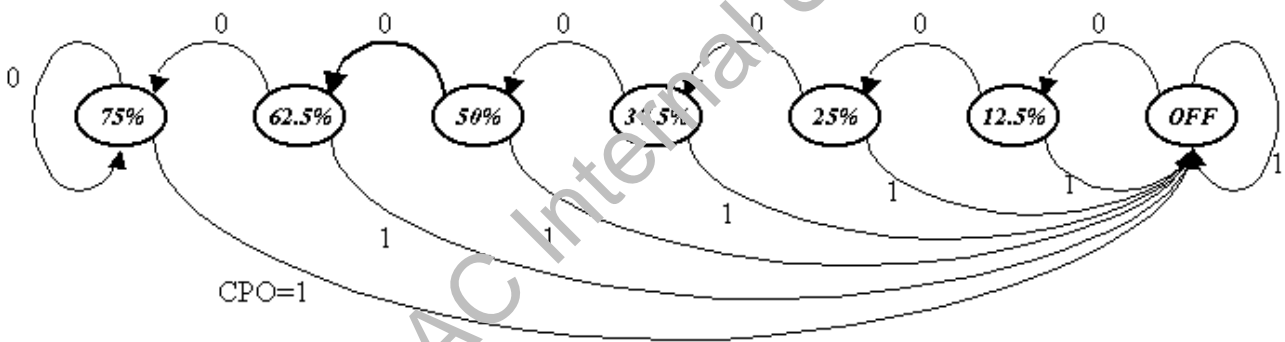

Fig 3 PWM Control state diagram

b.Shutdown Mode

In shutdown mode, a logic-low level on SHDB, pwm controller and the reference are disabled. The supply current drops to maximize battery life and the reference is pulled to ground. Every output voltage will decay. If unused, connect SHDB to VCC.

c.Oscillator Circuit

The boost-converter operating frequency was set at 1/16 times the system clock, DCLK. In A018AN03 V3's model. the DC-DC converter osc frequency is $DCLK/16=354.4\text{khz}$

C. Optical specification (Note 1, Note 2, Note 3)

Item	Symbol	Condition	Min.	Typ.	Max.	Unit	Remark
Response time	Rise	$\theta = 0^\circ$	-	25	50	ms	Note 4
	Fall		-	30	60	ms	
Contrast ratio	CR	At optimized viewing angle	60	150	-		Note 5,6
Viewing angle	Top	$CR \geq 10$	10	-	-	deg.	Note 7
	Bottom		30	-	-		
	Left		40	-	-		
	Right		40	-	-		
Brightness	Y_L	$\theta = 0^\circ$	180	240	-	cd/m ²	Note 8
White chromaticity	X	$\theta = 0^\circ$	0.26	0.31	0.36		
	y	$\theta = 0^\circ$	0.29	0.35	0.40		

Note 1. Ambient temperature =25°C. And backlight current $I_L=20\text{ mA}$

Note 2. To be measured in the dark room.

Note 3. To be measured on the center area of panel with a field angle of 1° by Topcon luminance meter BM-7, after 10 minutes operation.

Note 4. Definition of response time:

The output signals of photo detector are measured when the input signals are changed from “black” to “white”(falling time) and from “white” to “black”(rising time), respectively. The response time is defined as the time interval between the 10% and 90% of amplitudes. Refer to figure as below.

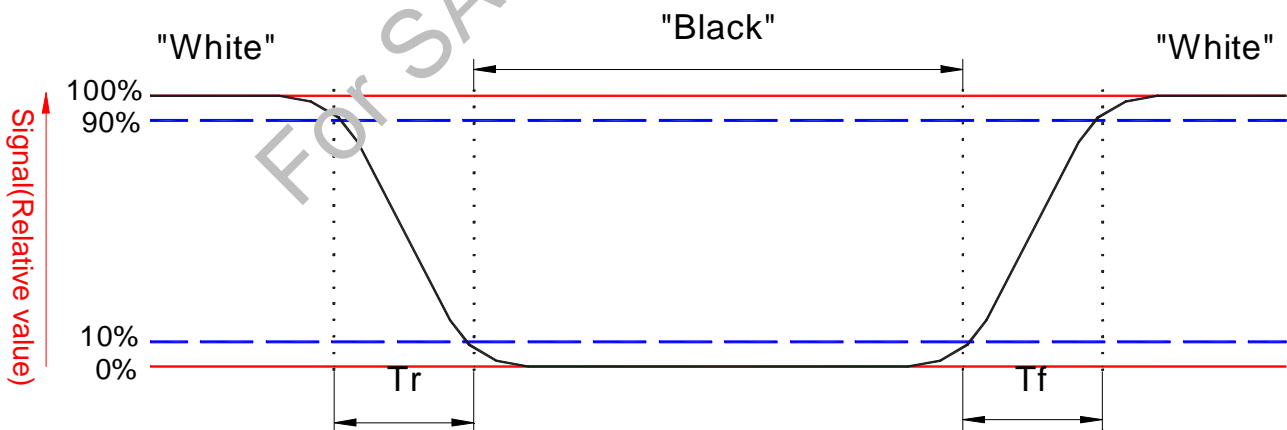

Note 5. Definition of contrast ratio:

Contrast ratio is calculated with the following formula.

$$\text{Contrast ratio (CR)} = \frac{\text{Photo detector output when LCD is at "White" state}}{\text{Photo detector output when LCD is at "Black" state}}$$

Note 6. White $V_i = V_{i50} \mp 1.5V$

Black $V_i = V_{i50} \pm 2.0V$

“±” Means that the analog input signal swings in phase with COM signal.

“ $\frac{-}{+}$ ” Means that the analog input signal swings out of phase with COM signal.
 V_{150} : The analog input voltage when transmission is 50%
 The 100% transmission is defined as the transmission of LCD panel when all the input terminals of module are electrically opened.

Note 7. Definition of viewing angle:, refer to figure as below.

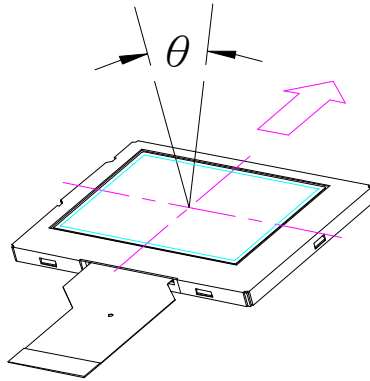

Note 8. Measured at the center area of the panel when all the input terminals of LCD panel are electrically opened.

For SAC Internal Use Only

D. Reliability test items:

No.	Test items	Conditions	Remark
1	High temperature storage	Ta= 80°C 240Hrs	
2	Low temperature storage	Ta= -25°C 240Hrs	
3	High temperature operation	Ta= 60°C 240Hrs	
4	Low temperature operation	Ta= 0°C 240Hrs	
5	High temperature and high humidity	Ta= 60°C . 90% RH 240Hrs	Operation
6	Heat shock	-25°C ~80°C, 50 cycle, 2Hrs/cycle	Non-operation
7	Electrostatic discharge	±200V,200pF(0Ω), once for each terminal	Non-operation
8	Vibration	Frequency range : 10~55Hz Stoke : 1.5mm Sweep : 10~55Hz~10Hz 2 hours for each direction of X,Y,Z (6 hours for total)	Non-operation JIS C7021, A-10 condition A
9	Mechanical shock	100G . 6ms, ±X,±Y,±Z 3 times for each direction	Non-operation JIS C7021, A-7 condition C
10	Vibration (with carton)	Random vibration: 0.015G ² /Hz from 5~200Hz -6dB/Octave from 200~500Hz	IEC 68-34
11	Drop (with carton)	Height: 60cm 1 corner, 3 edges, 6 surfaces	
12	The copper's strength for FPC	The strength is larger 0.7 kg/cm	IPC TM650
13	The film's strength for FPC	The strength is larger 0.35 kg/cm	IPC TM650
14	Flexible ability for FPC	1. curved radius: 2mm 2. curved angle: 270° 3. Pulling force: 500g	MIT folm: Diagram of test set up for folding endurance

Note: Ta: Ambient temperature.



E. Packing form

For SAC Internal Use Only

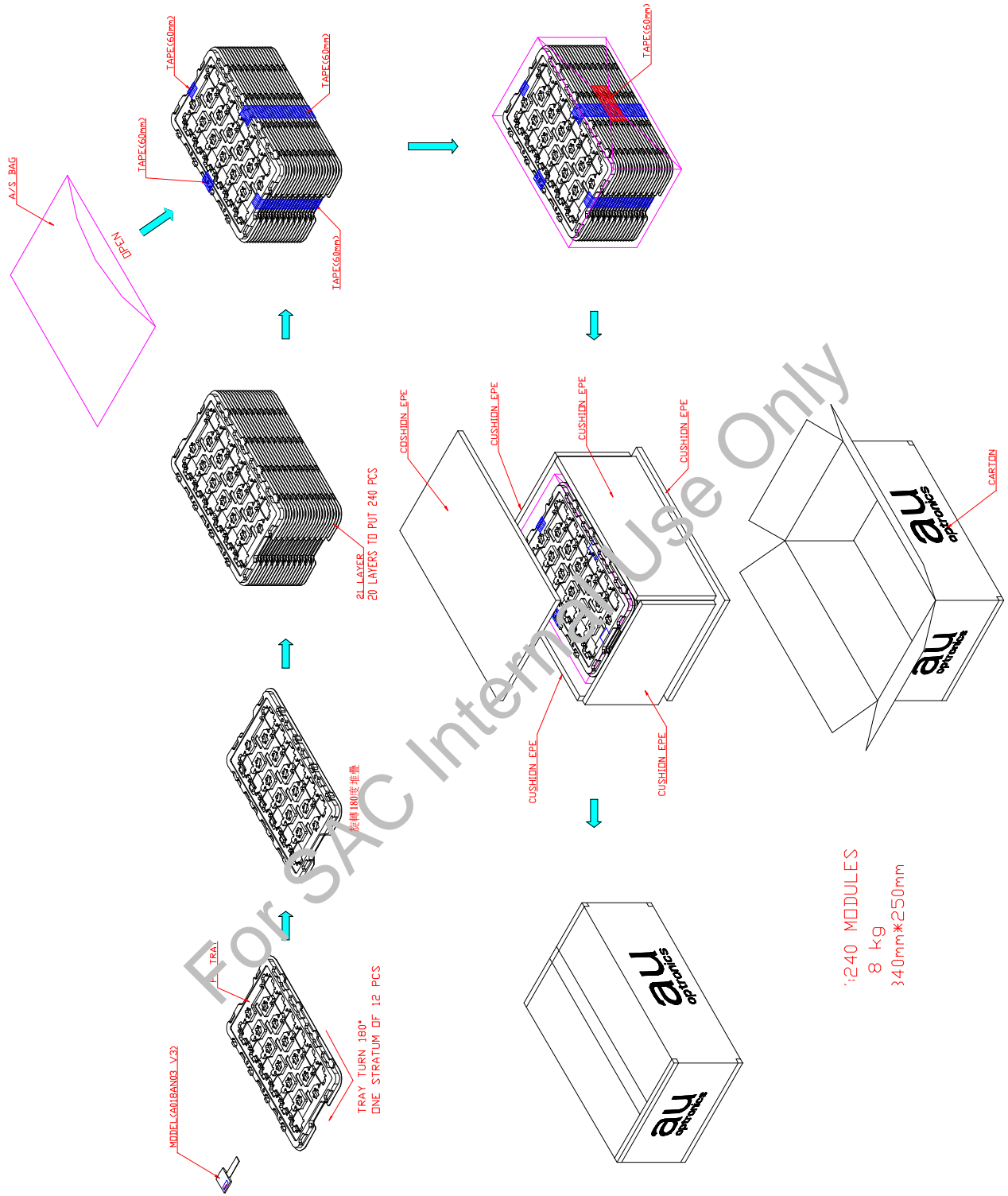

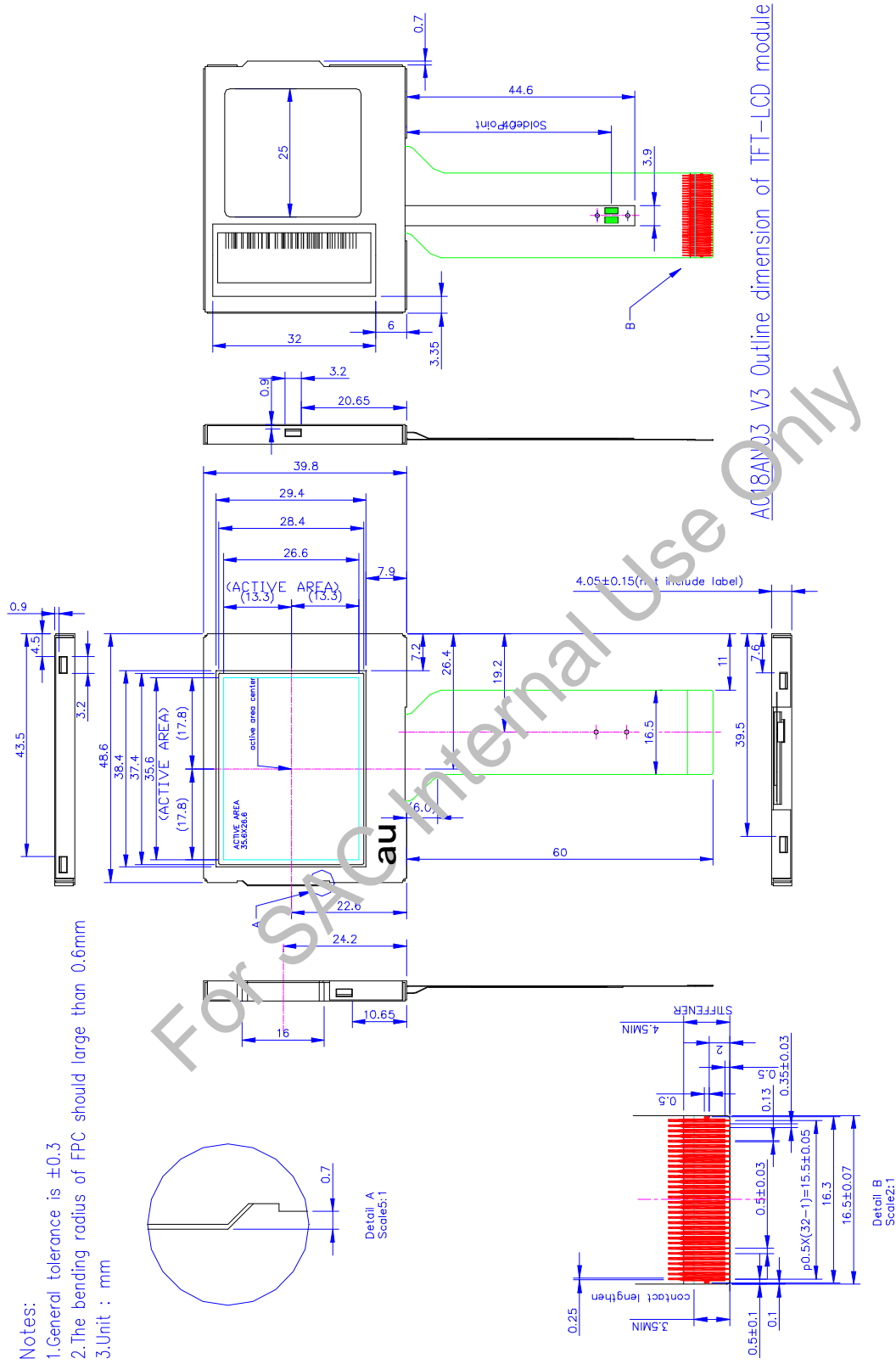

Fig. 4 outline dimension of TFT-LCD module

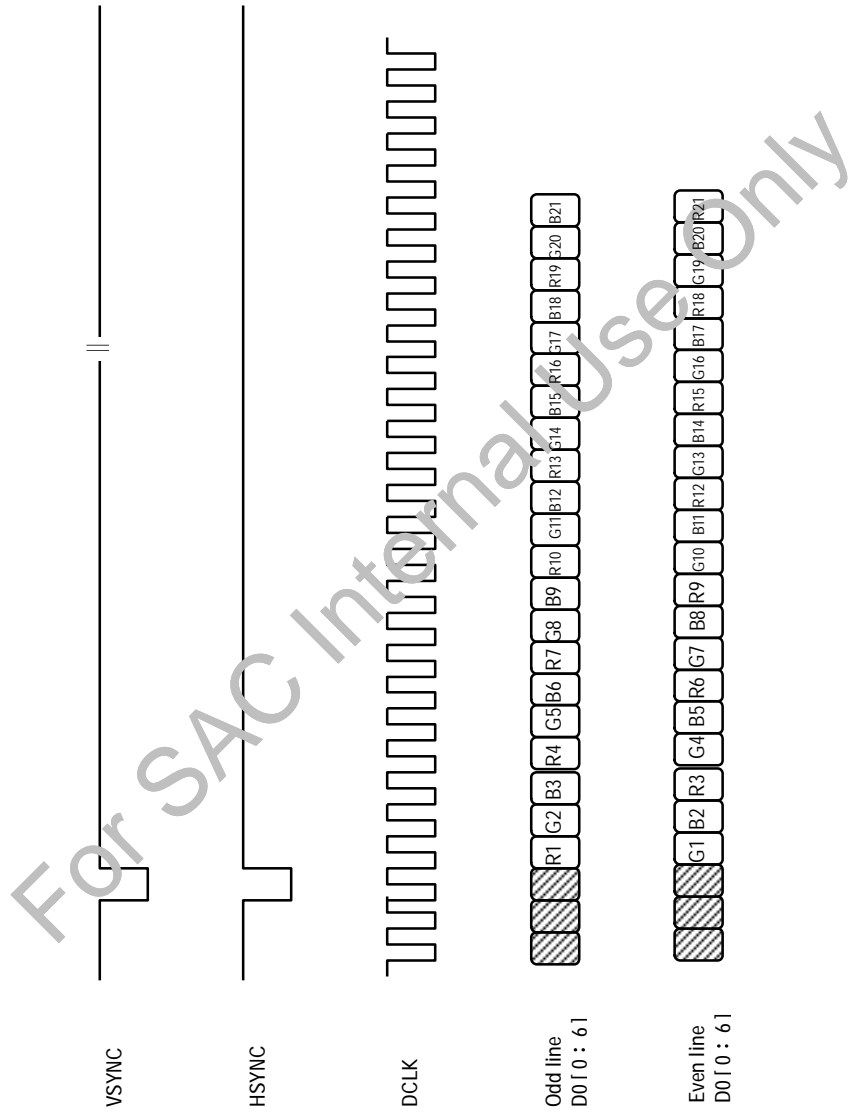

Fig. 5 Input signals timing relationship

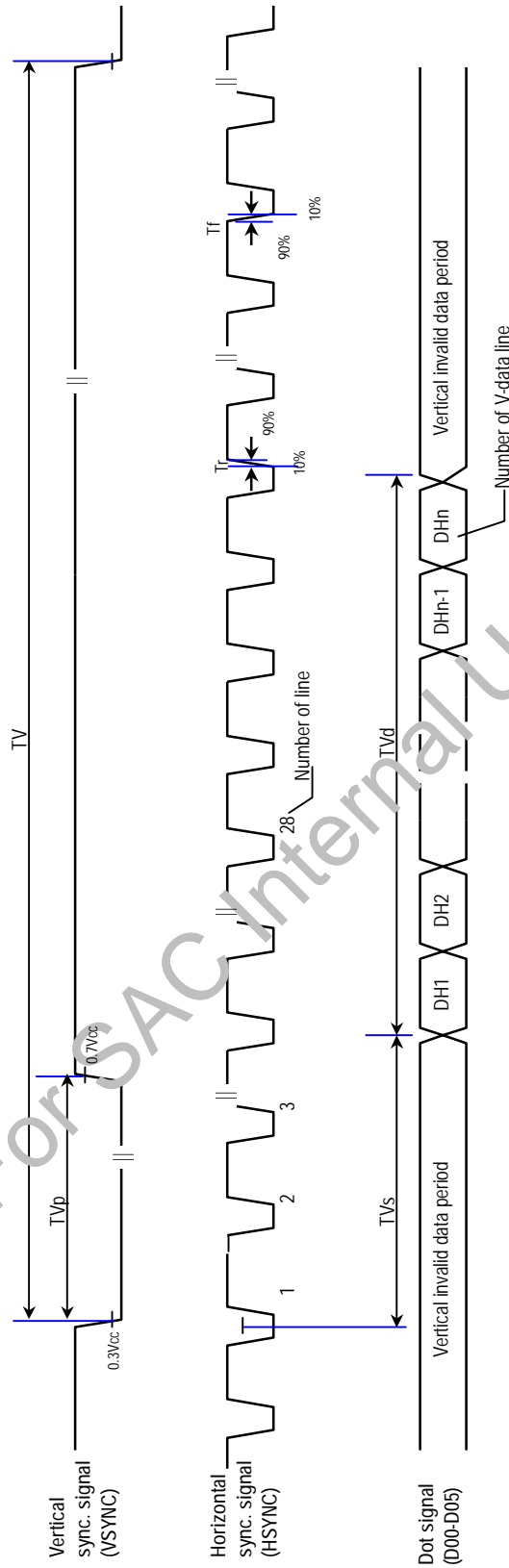

Fig. 6 Input Vertical Timing

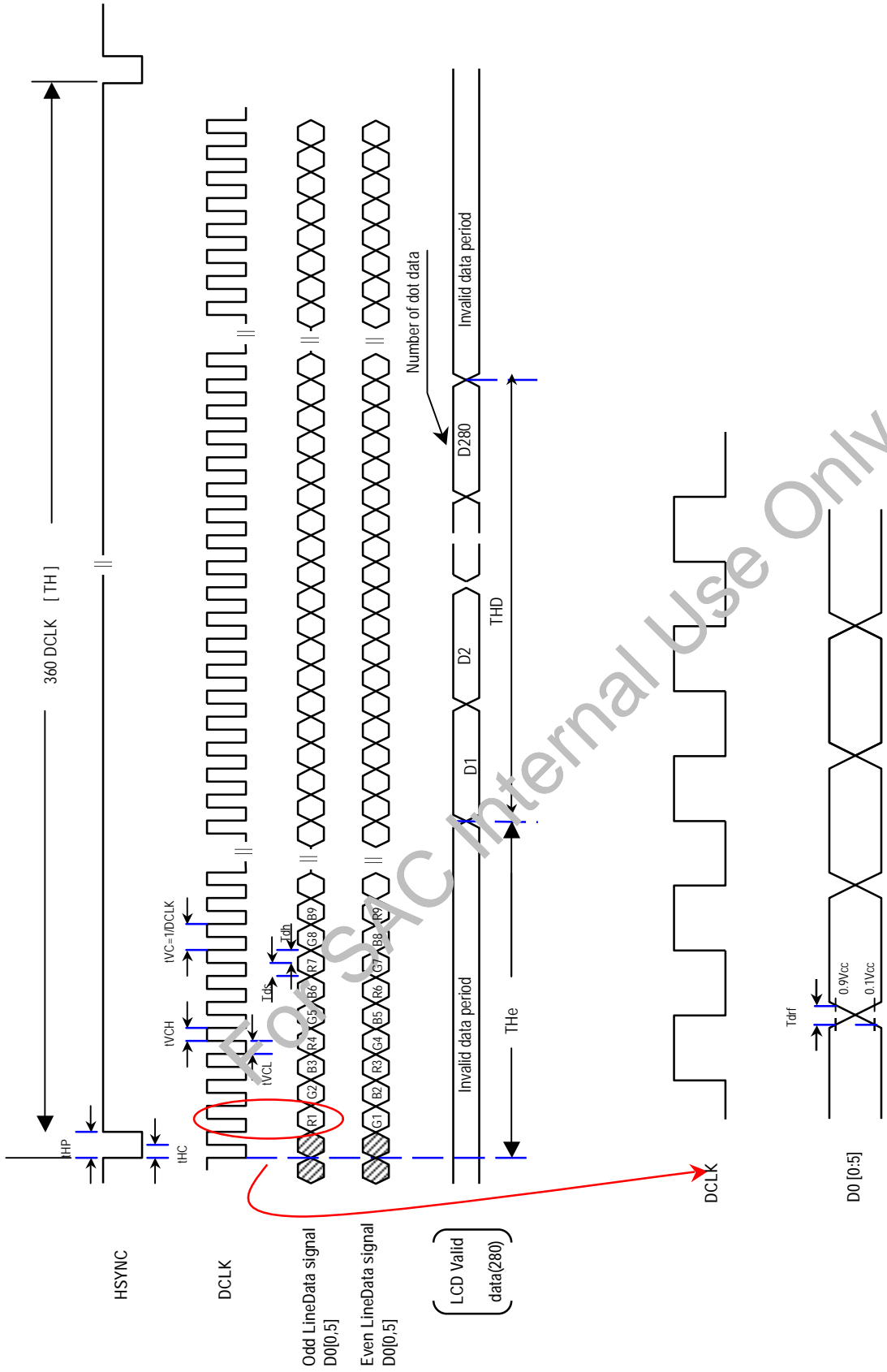

Fig. 7 Horizontal Input Timing)

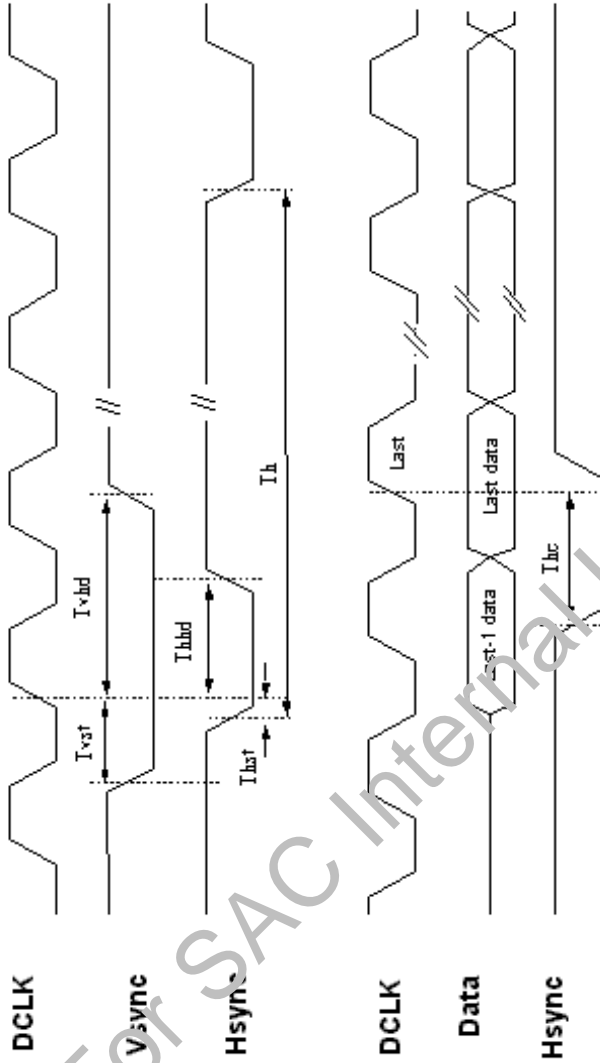

Fig. 9 Hsync, Vsync, Data, DCLK relationship

Application Circuit

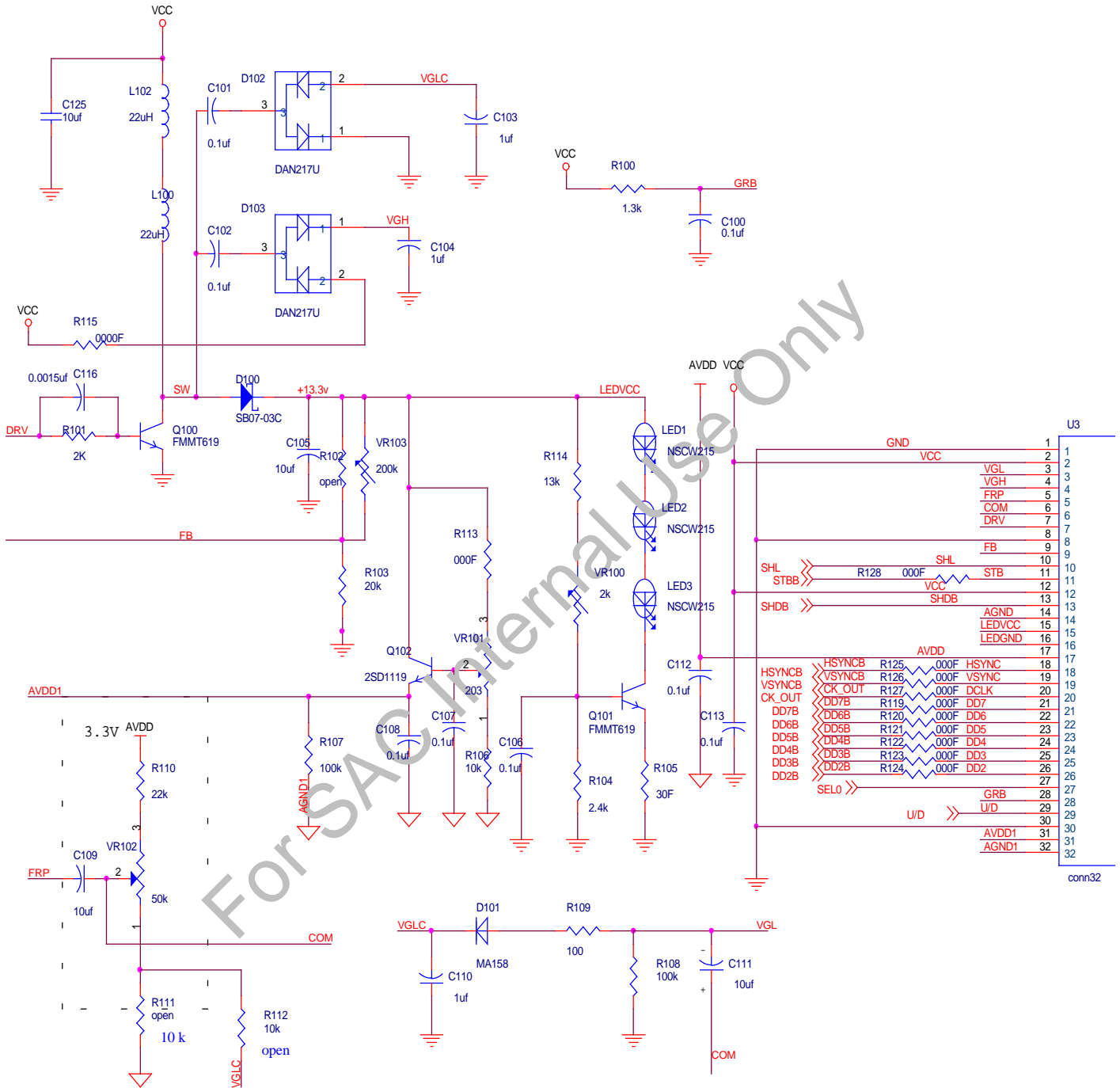

Fig. 10 Typical application circuit (for reference)