

① PHYSICAL DIMENSION

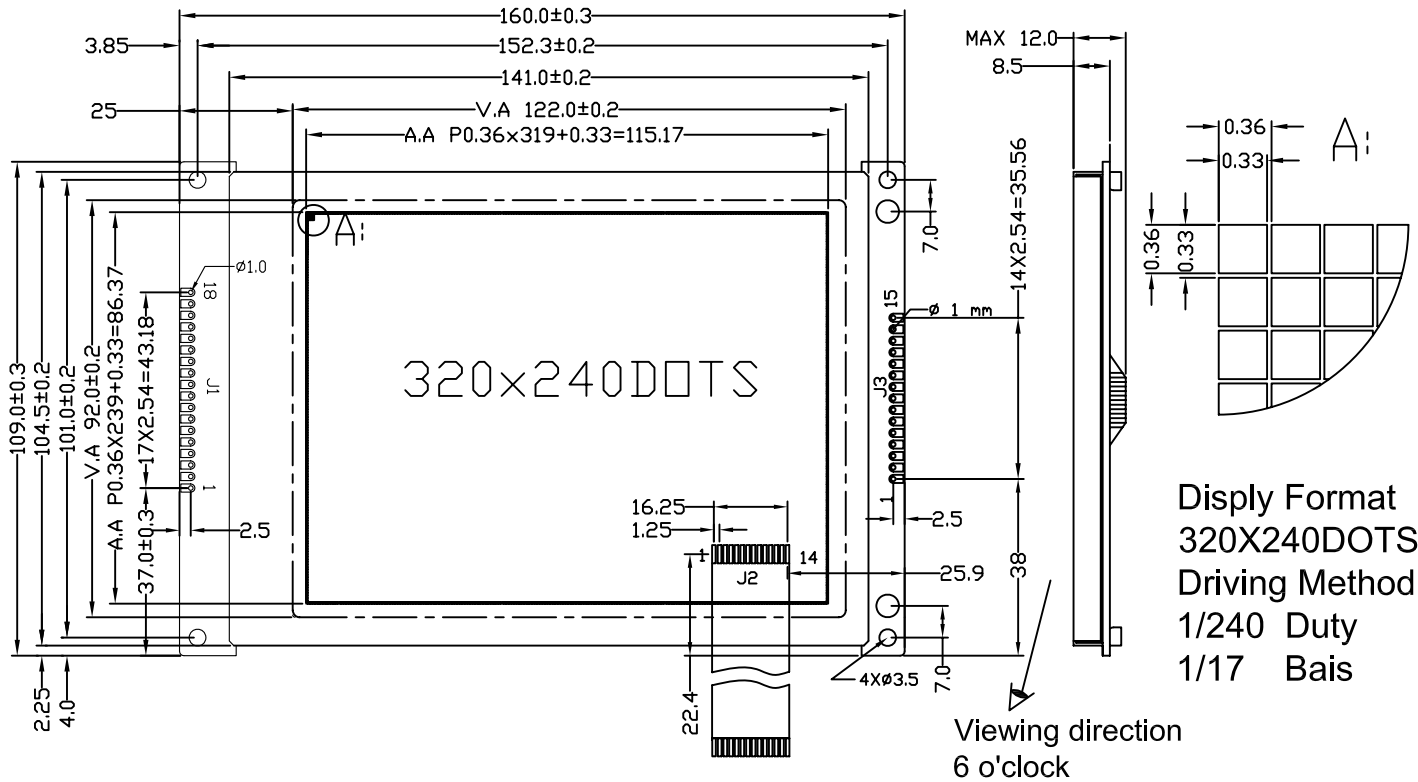

② MECHANICAL DATA

ITEM	SPECIFICATION	UNIT
Module Size With B/L (W X H X T)	160X109X12	mm
Viewing Area (W X H)	122X92	mm
Number of Dots (W X H)	320X240	dots
Dot Pitch (W X H)	0.36X0.36	mm
Dot Size (W X H)	0.33X0.33	mm
Weight	100.0 (With B/L)	g

④ BLOCK DIAGRAM

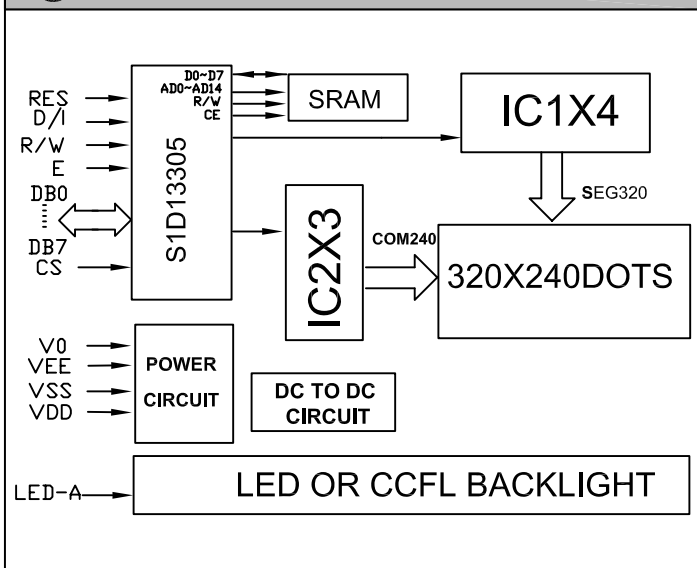

③ PIN CONFIGURATION

ITEM	J1	DESCRIPTION(带控制器)	J3	DESCRIPTION(不带控制器)
1	GND	Power Ground	D0 D3	Data bus [0~3]. There state I/O common terminal.
2	VCC	Power Positive		
3	V0	Negative Volt Adjust		
4	WR	Write Signal		
5	RD	Read Signal	DISP	Display ON/OFF
6	CS	Chip Select	FLM	Frame signal
7	A0	H:Data L:Instruction Code	M	Alternate signal for LCD
8	RST	Reset Signal	LP	Data Latch Pulse
9	DB0 DB7	Data bus [0~7]. There state I/O common terminal.	CP	Data shift Pulse
10			VCC	Power Positive
11			GND	Power Ground
12			VOUT	Negative Volt Output
13			V0	Negative Volt Adjust
14			FG	Frame Ground
15			LED-A	Backlight Anode(+5V)
16	DB7			
17	LED-A	Backlight Anode(+5V)		
18	VEE	Negative Volt Supply		

⑤ ABSOLUTE MAXIMUM RATINGS (25°C)

PARAMETER	SYMBOL	MIN.	MAX.	UNIT
SUPPLY VOLTAGE LOGIC	VDD	0	5.5	V
SUPPLY VOLTAGE DRIVER	VDD-VEE	0	23	V
INPUT VOLTAGE	VIN	0	VDD	V