

REV.	ECN. NO.	APPD
X1		Corel

NOTES:

- HOOK ACCEPT P.C.B. THICKNESS 1.57 ± 0.08 [.062±.003]
- SPECIFICATION:
 - ELECTRICAL CHARACTERISTICS:
 - CONTACT CURRENT RATING: 3 AMPERES .
 - CONTACT RESISTANCE: 35 milliohms(MAX.).
 - INSULATION RESISTANCE: 5000 Megohms (MIN).
 - DIELECTRIC WITHSTANDING VOLTAGE: 1000 VAC (MIN).
AT SEA LEVEL.
 - MECHANICAL CHARACTERISTICS
 - CONTACT RETENTION FORCE: 1.82 Kgf MIN.
 - OPERATING TEMPERATURE: -55 °C TO +105 °C
 - DURABILITY: 500 CYCLES.
 - FOXNUT IS AN INTEGRAL PART THAT COULDN'T BE SCREWED OFF.
- "RoHS" COMPLIANT.

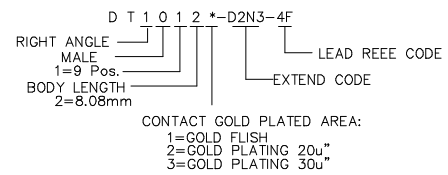
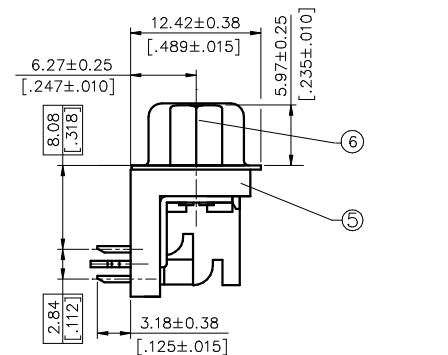
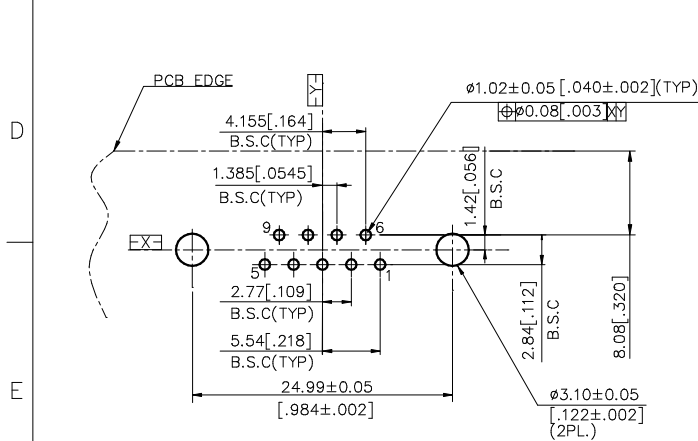
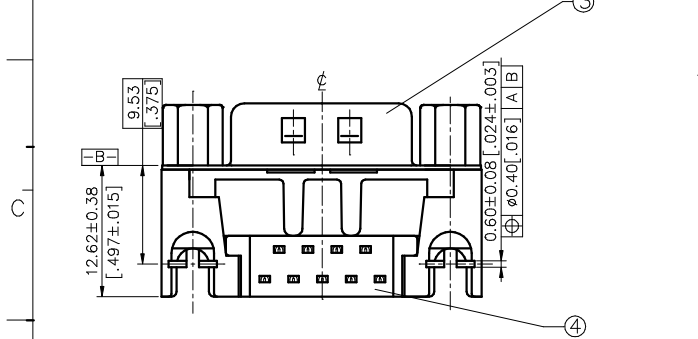
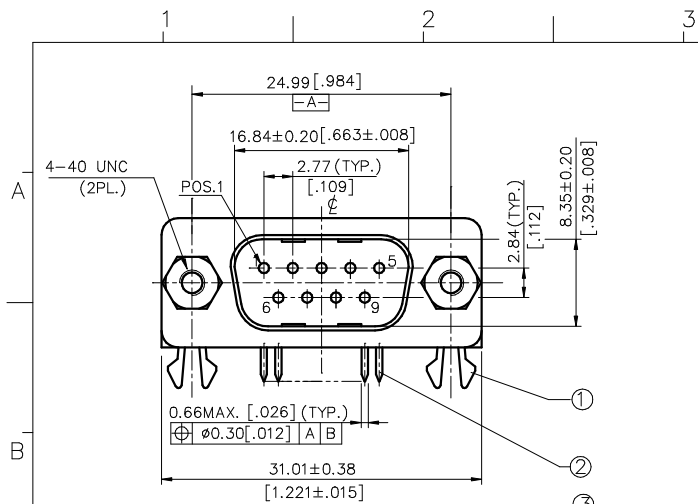
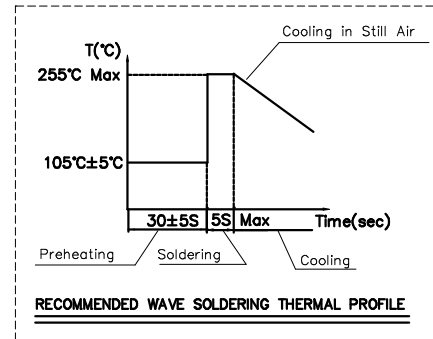

ITEM	DESC.	Q'TY	MATERIAL	TREATMENT
6	FOXNUT	2	ZINC	NICKEL PLATED
5	HOUSING	1	THERMOPLASTIC UL 94V-0	MOLDED TEAL 322C
4	SPACER	1	THERMOPLASTIC UL 94V-0	MOLDED TEAL 322C
3	SHELL	1	STEEL	TIN PLATED
2	CONTACT	9	COPPER ALLOY	GOLD PLATING AT CONTACT AREA, 100- 200u"Sn ALLOY (LEAD FREE)PLATED AT TAIL, OVER 50u" NICKEL OVERALL
1	BOARD LOCK	2	STEEL	TIN PLATED

x.±	x°.±	UNITS mm [INCH]	NAME(INTENDED USE)	FOXCONN HON HAI PRECISION IND. CO.,LTD. TAIPEI, TAIWAN, R.O.C.
.x ±	.x°.±	MAT'L	CUSTOMER	
.xx ± ^{0.25} [.010]	.xx°.±	N/A	PART NO.(INTENDED USE)	TITLE: DYNASTY "D" MALE P/M R/A .318
.xxx ±	.xxx°.±	FINISH	DT1012*-D2N3-4F	DWG NO.: 301-0000-****
THESE DRAWINGS AND SPECIFICATIONS ARE THE PROPERTY OF HON HAI PRECISION IND. CO., LTD. AND SHALL NOT BE REPRODUCED, COPIED OR USED IN ANY MANNER WITHOUT THE PRIOR WRITTEN CONSENT OF HON HAI PRECISION IND. CO., LTD.		Q'TY	APPD: Corel Zhu 4/28'07	CHKD: X.H. Xiang 4/28'07
			DR: Wan Wei 4/28'07	SCALE SHEET REV. 1:1 1/1 X1

