

CRS05

Angular Rate Sensor



A robust and affordable mass-produced gyroscope for automotive and commercial customers.

Angular rate sensors are used wherever rate of turn sensing is required without a fixed point of reference. The sensor will output a DC voltage proportional to the rate of turn and input voltage.

High performance motion sensing even under severe shock and vibration.

Whatever your application, the unique silicon ring technology, coupled with closed loop electronics, gives advanced and stable performance over time and temperature, overcoming the mount sensitivity problems experienced with simple beam or tuning fork based sensors.

Key Features

- Excellent performance over temperature
- Repeatable drift characteristic
- High shock and vibration operation
- Automotive approved part
- Low mass and small size
- High temperature operation
- Built in Test (BIT)



CRS05

Angular Rate Sensor

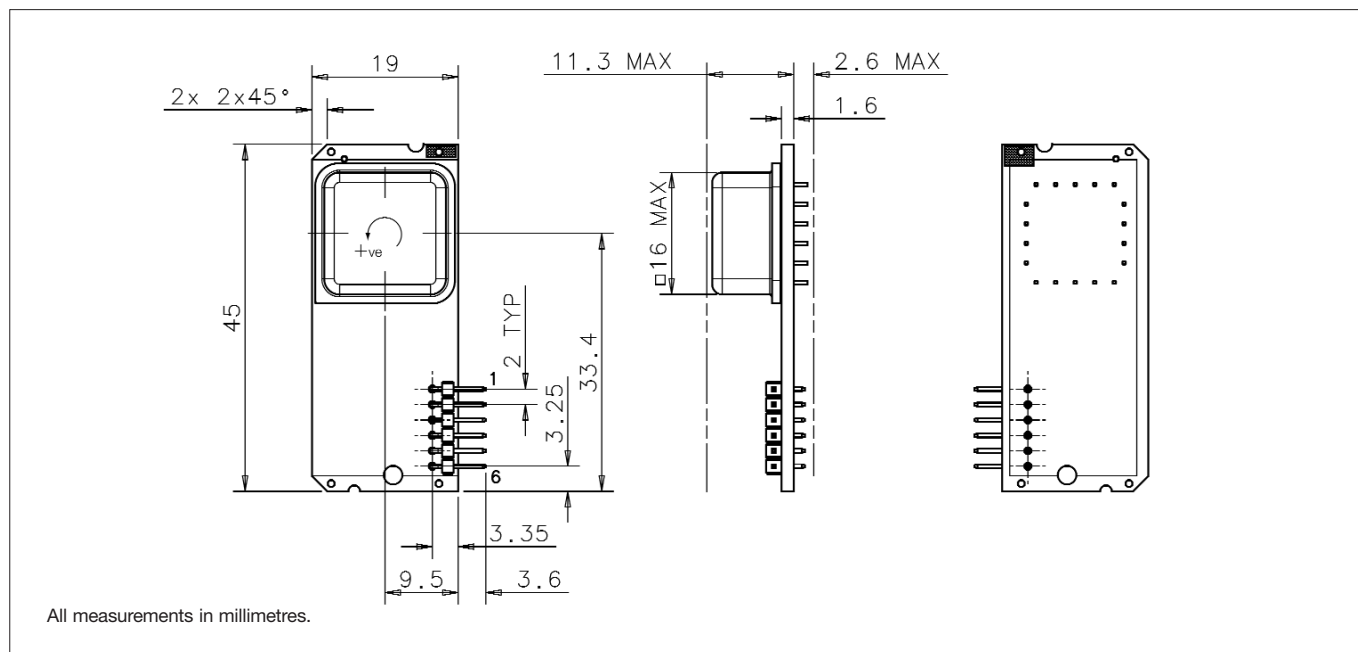

Specification

Specification (Typical Data)	-01	-02	-75
Angular Rate Range	±50°/s	±200°/s	±75°/s
Output	Analogue voltage (ratiometric)		
Scale Factor			
Nominal	40mV/°/s	10mV/°/s	27mV/°/s
Variation over temperature range	< ±3%		
Nonlinearity	< ±1.0% of full scale		
Bias			
Setting tolerance	< ±1.5°/s		
Variation over temperature range	< ±3°/s		
Ratiometric error	< ±1°/s		
Drift vs. time	< ±0.5°/s (after start-up time)		
g sensitivity	< ±0.025°/s/g on any axis		
Bandwidth (-90° Phase)	80Hz	30Hz	40Hz
Quiescent Noise	< 85mV rms	< 4mV rms	< 8mV rms
Environment			
Temperature	-40°C to +100°C		
Linear acceleration	< 100g		
Shock	200g (1ms, ½ sine)		
Vibration	2g rms (20Hz to 2kHz, random)		
Cross-axis sensitivity	< 5%		
Mass	< 11 gram		
Electrical			
Supply voltage	+4.75V to +5.25V		
Supply current	< 35mA (running)		
Noise and ripple	< 10mV rms (up to 10kHz)		
Start-up time	< 0.5s		
RoHS Compliance	No		

Pin Connections

1	Rate Output
2	+5V
3	CBIT
4	0V
5	BIT
6	N/C

Silicon Sensing Systems Limited
Cliffatford Road Southway
Plymouth Devon
PL6 6DE United Kingdom

T: +44 (0)1752 723330
F: +44 (0)1752 723331
E: sales@siliconsensing.com
W: siliconsensing.com

Silicon Sensing Systems Japan Limited
1-10 Fuso-Cho
Amagasaki
Hyogo 6600891 Japan

T: +81 (0)6 6489 5868
F: +81 (0)6 6489 5910
E: sales@siliconsensing.com
W: siliconsensing.com

Specification subject to change without notice.

© Copyright 2007
Silicon Sensing Systems Limited
All rights reserved.
Printed in England 04/07