

MM3Z2V0~MM3Z120

SILICON PLANAR ZENER DIODES

FEATURES

- Total power dissipation : max. 300 mW
- Small plastic package suitable for surface mounted design
- Tolerance approximately $\pm 5\%$

DESCRIPTION

Silicon planar zener diode in a small plastic SMD SOD-323 package

PINNING

PIN	DESCRIPTION
1	Cathode
2	Anode

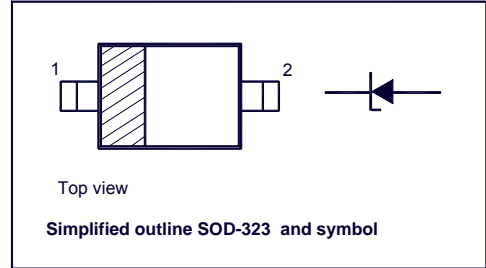

Absolute Maximum Ratings ($T_a = 25\text{ }^\circ\text{C}$)

Parameter	Symbol	Value	Unit
Power Dissipation	P_{tot}	300	mW
Junction Temperature	T_j	150	$^\circ\text{C}$
Storage Temperature Range	T_s	- 55 to + 150	$^\circ\text{C}$

Characteristics at $T_{amb} = 25\text{ }^\circ\text{C}$

Parameter	Symbol	Max.	Unit
Thermal Resistance Junction to Ambient Air	R_{thA}	0.3	K/mW
Forward Voltage at $I_F = 10\text{ mA}$	V_F	0.9	V

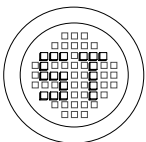

®

SEMTECH ELECTRONICS LTD.

(Subsidiary of Semtech International Holdings Limited, a company listed on the Hong Kong Stock Exchange, Stock Code: 724)



Dated : 02/08/2006

MM3Z2V0~MM3Z120

Type	Marking Code	Zener Voltage Range ¹⁾			Dynamic Impedance ²⁾		Reverse Leakage Current		Temp. coefficient of Zener Voltage
		V _{znom} V	I _{ZT} mA	for V _{ZT} V	Z _Z (Max) Ω	at I _Z mA	I _R (Max) μA	at V _R V	TKvz %/K
MM3Z2V0	B0	2.0	5	1.80...2.15	100	5	120	0.5	-0.09...-0.06
MM3Z2V2	C0	2.2	5	2.08...2.33	100	5	120	0.7	-0.09...-0.06
MM3Z2V4	1C	2.4	5	2.28...2.56	100	5	120	1	-0.09...-0.06
MM3Z2V7	1D	2.7	5	2.5...2.9	110	5	120	1	-0.09...-0.06
MM3Z3V0	1E	3.0	5	2.8...3.2	120	5	50	1	-0.08...-0.05
MM3Z3V3	1F	3.3	5	3.1...3.5	130	5	20	1	-0.08...-0.05
MM3Z3V6	1H	3.6	5	3.4...3.8	130	5	10	1	-0.08...-0.05
MM3Z3V9	1J	3.9	5	3.7...4.1	130	5	5	1	-0.08...-0.05
MM3Z4V3	1K	4.3	5	4...4.6	130	5	5	1	-0.06...-0.03
MM3Z4V7	1M	4.7	5	4.4...5	130	5	2	1	-0.05...+0.02
MM3Z5V1	1N	5.1	5	4.8...5.4	130	5	2	1.5	-0.02...+0.02
MM3Z5V6	1P	5.6	5	5.2...6	80	5	1	2.5	-0.05...+0.05
MM3Z6V2	1R	6.2	5	5.8...6.6	50	5	1	3	0.03...0.06
MM3Z6V8	1X	6.8	5	6.4...7.2	30	5	0.5	3.5	0.03...0.07
MM3Z7V5	1Y	7.5	5	7...7.9	30	5	0.5	4	0.03...0.07
MM3Z8V2	1Z	8.2	5	7.7...8.7	30	5	0.5	5	0.03...0.08
MM3Z9V1	2A	9.1	5	8.5...9.6	30	5	0.5	6	0.03...0.09
MM3Z10	2B	10	5	9.4...10.6	30	5	0.1	7	0.03...0.1
MM3Z11	2C	11	5	10.4...11.6	30	5	0.1	8	0.03...0.11
MM3Z12	2D	12	5	11.4...12.7	35	5	0.1	9	0.03...0.11
MM3Z13	2E	13	5	12.4...14.1	35	5	0.1	10	0.03...0.11
MM3Z15	2F	15	5	13.8...15.6	40	5	0.1	11	0.03...0.11
MM3Z16	2H	16	5	15.3...17.1	40	5	0.1	12	0.03...0.11
MM3Z18	2J	18	5	16.8...19.1	45	5	0.1	13	0.03...0.11
MM3Z20	2K	20	5	18.8...21.2	50	5	0.1	15	0.03...0.11
MM3Z22	2M	22	5	20.8...23.3	55	5	0.1	17	0.04...0.12
MM3Z24	2N	24	5	22.8...25.6	60	5	0.1	19	0.04...0.12
MM3Z27	2P	27	5	25.1...28.9	70	2	0.1	21	0.04...0.12
MM3Z30	2R	30	5	28...32	80	2	0.1	23	0.04...0.12
MM3Z33	2X	33	5	31...35	80	2	0.1	25	0.04...0.12
MM3Z36	2Y	36	5	34...38	90	2	0.1	27	0.04...0.12
MM3Z39	2Z	39	2.5	37...41	100	2	2	30	0.04...0.12
MM3Z43	3A	43	2.5	40...46	130	2	2	33	0.04...0.12
MM3Z47	3B	47	2.5	44...50	150	2	2	36	0.04...0.12
MM3Z51	3C	51	2.5	48...54	180	2	1	39	0.04...0.12
MM3Z56	3D	56	2.5	52...60	180	2	1	43	0.04...0.12
MM3Z62	3E	62	2.5	58...66	200	2	0.2	47	0.04...0.12
MM3Z68	3F	68	2.5	64...72	250	2	0.2	52	0.04...0.12
MM3Z75	3H	75	2.5	70...79	300	2	0.2	57	0.04...0.12
MM3Z82	3J	82	2.5	77...87	300	2	0.2	63	0.05...0.12
MM3Z91	3K	91	1	85...96	700	1	0.2	69	0.05...0.12
MM3Z100	3M	100	1	94...106	700	1	0.2	76	0.05...0.12
MM3Z110	3N	110	1	104...116	800	1	0.2	84	0.05...0.12
MM3Z120	3P	120	1	114...127	900	1	0.2	91	0.05...0.12

¹⁾ V_Z is tested with pulses (20 ms).

²⁾ Z_Z is measured at I_Z by given a very small A.C. current signal.

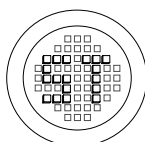

SEMTECH ELECTRONICS LTD.

(Subsidiary of Semtech International Holdings Limited, a company listed on the Hong Kong Stock Exchange, Stock Code: 724)



ISO/TS 16949 : 2002 Certificate No. 05103
 ISO 14001:2004 Certificate No. 7116
 ISO 9001:2000 Certificate No. 0506098

Dated : 02/08/2006

MM3Z2V0~MM3Z120

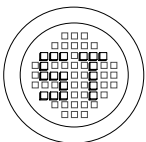
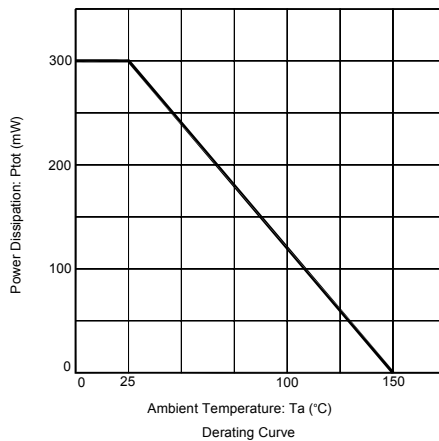
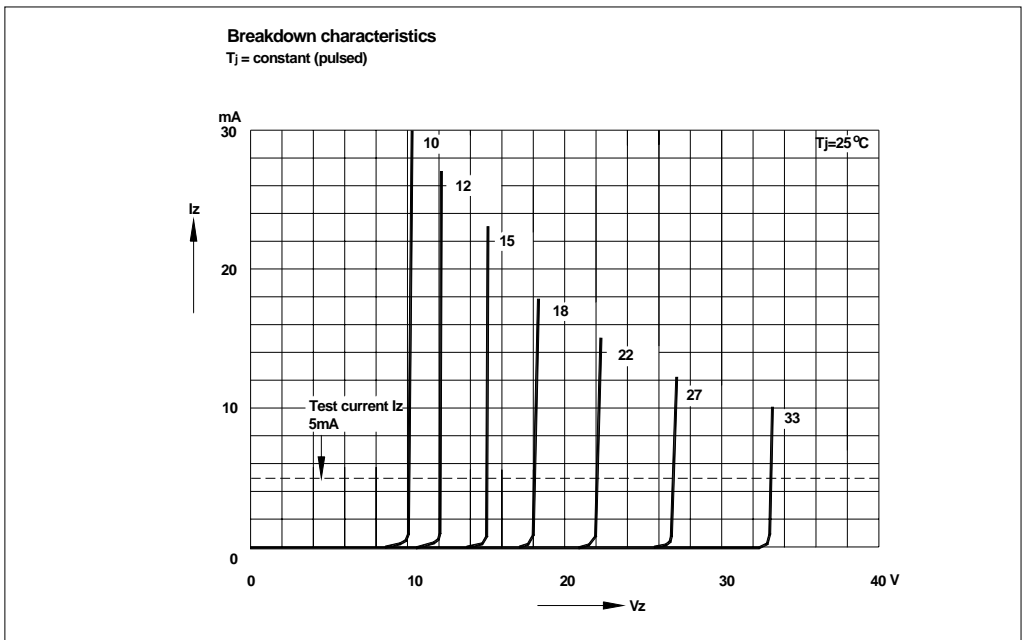
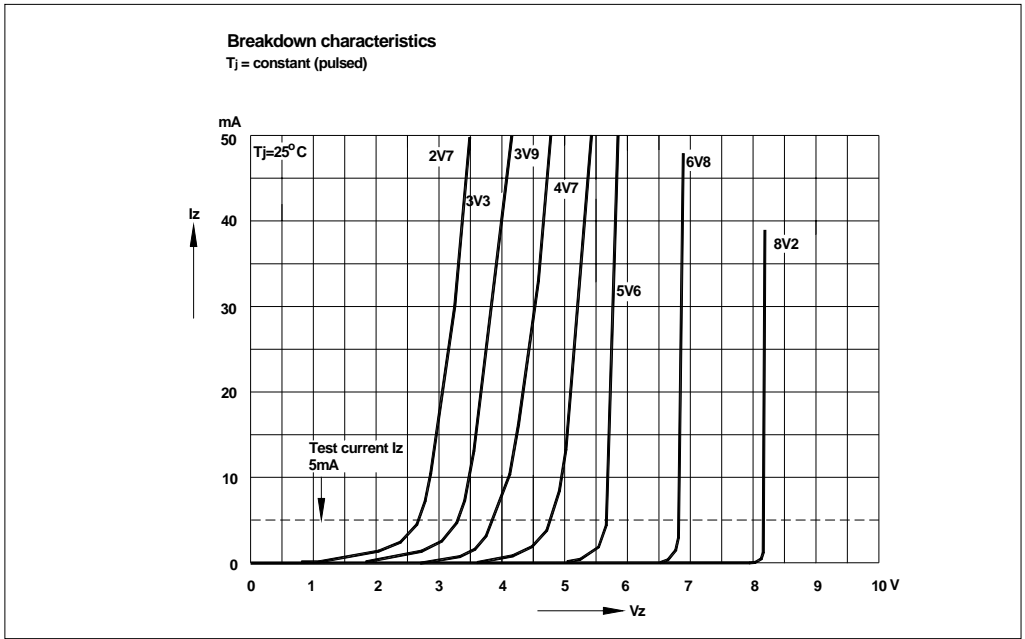

SEMTECH ELECTRONICS LTD.

(Subsidiary of Semtech International Holdings Limited, a company listed on the Hong Kong Stock Exchange, Stock Code: 724)



ISO/TS 16949 : 2002
 Certificate No. 05103



ISO 14001:2004
 Certificate No. 7116



ISO 9001:2000
 Certificate No. 0506098

Dated : 02/08/2006

MM3Z2V0~MM3Z120

PACKAGE OUTLINE

Plastic surface mounted package; 2 leads

SOD-323

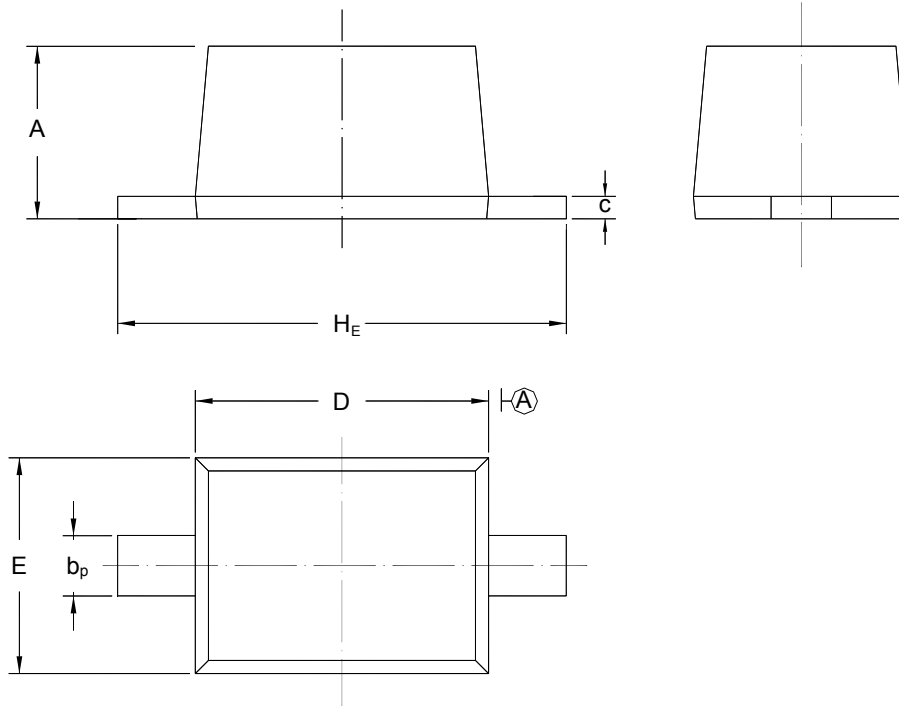

UNIT	A	b _p	C	D	E	H _E
mm	1.10 0.80	0.40 0.25	0.15 0.00	1.80 1.60	1.35 1.15	2.80 2.30

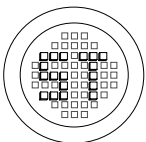

SEMTECH ELECTRONICS LTD.

(Subsidiary of Semtech International Holdings Limited, a company listed on the Hong Kong Stock Exchange, Stock Code: 724)

®



Dated : 02/08/2006