



General Description

The DSC1001 is a silicon MEMS based CMOS oscillator offering excellent jitter and stability performance over a wide range of supply voltages and temperatures. The device operates from 1 to 150MHz in increments of 100Hz (up to four decimal point resolution) with supply voltages between 1.8 to 3.3 Volts and extended temperatures from -40°C to 105°C.

The DSC1001 incorporates an all silicon resonator that is extremely robust and nearly immune to stress related fractures, common to crystal based oscillators. Without sacrificing the performance and stability required of today's systems, a crystal-less design allows for a higher level of reliability, making the DSC1001 ideal for rugged, industrial, and portable applications where stress, shock, and vibration can damage quartz crystal based systems.

Available in industry standard packages, the DSC1001 can be "dropped-in" to the same PCB footprint as standard crystal oscillators.

Block Diagram

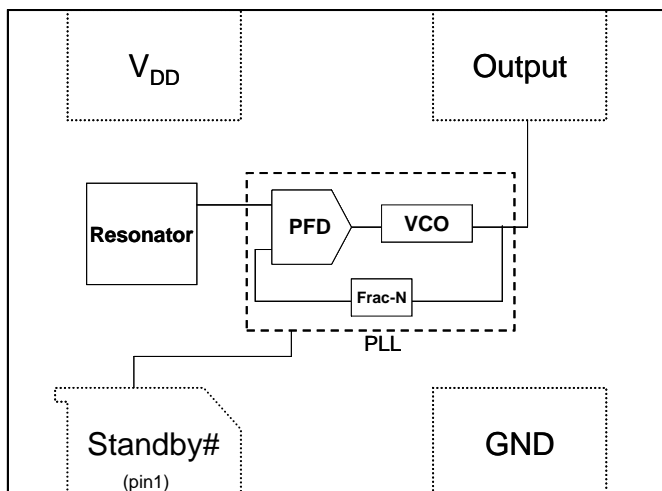

Features

- Frequency Range: 1 to 150MHz
- Exceptional Stability over Temperature
 - ±10 PPM, ±25 PPM, ±50 PPM
- Operating voltage
 - 1.7 to 3.6V
- Operating Temperature Range
 - Ext. Industrial -40°C to 105°C
 - Industrial -40°C to 85°C
 - Ext. Commercial -20°C to 70°C
 - Commercial 0°C to 70°C
- Low Operating and Standby Current
 - 5mA Operating (40MHz)
 - 15uA Standby
- Ultra Miniature Footprint
 - 2.5 x 2.0 x 0.85 mm
 - 3.2 x 2.5 x 0.85 mm
 - 5.0 x 3.2 x 0.85 mm
 - 7.0 x 5.0 x 0.85 mm
- Excellent shock and Vibration Resistance
- Lead Free, RoHS & Reach SVHC Compliant

Benefits

- Pin for pin "drop in" replacement for industry standard oscillators
- Semiconductor level reliability, significantly higher than quartz
- Frequency Resolution to 4 decimals
- Short mass production lead-times
- Longer Battery Life / Reduced Power
- Compact Plastic package
- Cost Effective

Applications

- Mobile Applications
- Consumer Electronics
- Portable Electronics
- DVR, CCTV, Surveillance Cameras
- Low Profile Applications
- Industrial Applications

More products information please contact telephone : 13418796700 Mr.Xiong

Can also send E-mail to : xander@yangxing.hk

Products website : www.fxyg86.cn.alibaba.com

Absolute Maximum Ratings¹

Item	Min.	Max	Unit	Condition
Supply Voltage	-0.3	+4.0	V	
Input Voltage	-0.3	VDD+0.3	V	
Junction Temp	-	+150	°C	
Storage Temp	-55	+150	°C	
Soldering Temp	-	+260	°C	40 sec max.
ESD	-		V	
HBM		4000		
MM		200		
CDM		1500		

Ordering Code

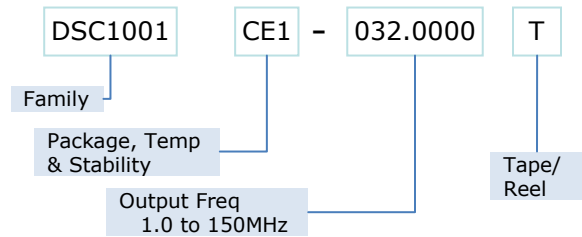

* See Ordering Information for details

Recommended Operating Conditions

Parameter	Symbol	Range
Supply Voltage	V _{DD}	1.7 – 3.6V
Output Load	Z _L	R>10KΩ, C≤15pF
Operating Temperature		
Option 1		-40 to +105 °C
Option 2	T	-40 to +85 °C
Option 3		-20 to +70 °C
Option 4		0 to +70 °C

Specifications (VDD = 1.8 to 3.3v) T_A=85°C unless otherwise specified

Parameter	Symbol	Condition	Min.	Typ	Max.	Unit
Frequency	f ₀	Single Frequency	1		150	MHz
Frequency Tolerance Ext. Industrial Industrial Extended Commercial Commercial	Δf	Includes frequency variations due to initial tolerance, temperature and power supply voltage			±25,±50 ±10,±25,±50 ±10,±25,±50 ±10,±25,±50	ppm
Aging	Δf	1 year @25°C			±5	ppm
Supply Current, standby	I _{DD}	T=25°C			15	uA
Output Logic Levels Output logic high Output logic low	V _{OH} V _{OL}	-4mA 4mA	0.8*V _{DD} -		- 0.2*V _{DD}	Volts
Output Startup Time ²	t _{SU}	T=25°C		3	8	ms
Output Disable Time	t _{DA}			20	100	ns
Output Duty Cycle	SYM		45		55	%
Input Logic Levels Input logic high Input logic low	V _{IH} V _{IL}		0.75*V _D D-		- 0.25* V _{DD}	Volts

VDD = 1.8v

Parameter	Symbol	Condition		Min.	Typ.	Max.	Unit
Supply Current, no load	I_{DD}	$C_L=0p$ $R_L=\infty$ $T=25^\circ C$	1 to 40MHz		5		mA
			40 to 80MHz		6		
			80 to 125MHz		7		
			125 to 150MHz		8	12	
Output Transition time		$C_L=15pF; T=25^\circ C$					
Rise Time	t_R	$20\%/80\%*V_{DD}$			1.8	3	ns
Fall Time	t_F				1.0	3	
Period Jitter					7		Ps rms
Jitter, Max Cycle to Cycle	J_{CC}	$F = 100MHz^2$			60		Ps

VDD = 2.5v

Parameter	Symbol	Condition		Min.	Typ.	Max.	Unit
Supply Current, no load	I_{DD}	$C_L=0p$ $R_L=\infty$ $T=25^\circ C$	1 to 40MHz		6		mA
			40 to 80MHz		7		
			80 to 125MHz		8		
			125 to 150MHz		9	13	
Output Transition time		$C_L=15pF; T=25^\circ C$					
Rise Time	t_R	$20\%/80\%*V_{DD}$			1.0	2	ns
Fall Time	t_F				0.9	2	
Period Jitter					6		Ps rms
Jitter, Max Cycle to Cycle	J_{CC}	$F = 100MHz^2$			50		ps

VDD = 3.3v

Parameter	Symbol	Condition		Min.	Typ.	Max.	Unit
Supply Current, no load	I_{DD}	$C_L=0p$ $R_L=\infty$ $T=25^\circ C$	1 to 40MHz		7		mA
			40 to 80MHz		8		
			80 to 125MHz		9		
			125 to 150MHz		10	14	
Output Transition time		$C_L=15pF; T=25^\circ C$					
Rise Time	t_R	$20\%/80\%*V_{DD}$			1.0	2	ns
Fall Time	t_F				0.9	2	
Period Jitter					6		Ps rms
Jitter, Max Cycle to Cycle	J_{CC}	$F = 100MHz^2$			50		ps

Notes:

1. Absolute maximum ratings are those values beyond which the safety of the device cannot be guaranteed. The device should not be operated beyond these limits.
2. Measured over 50k clock cycles.

Nominal Performance Characteristics

Supply Current

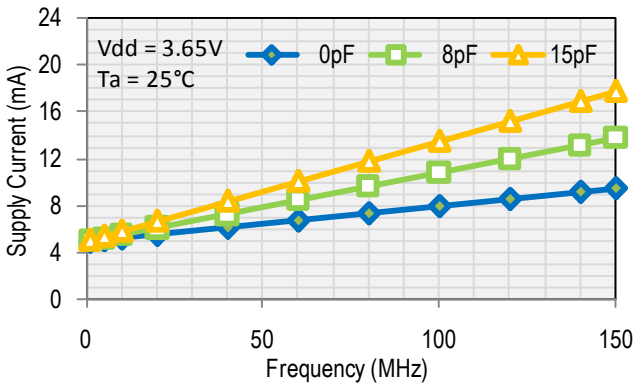

Supply Current

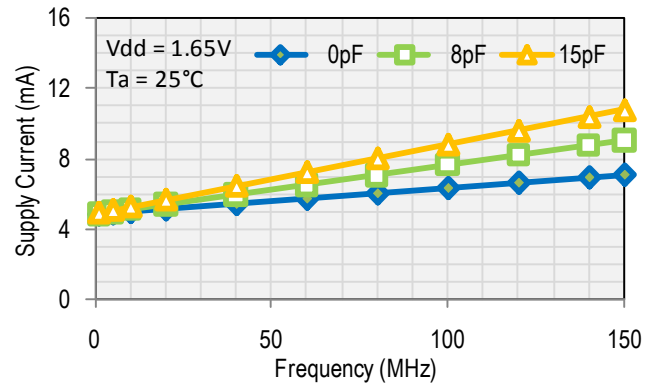

Rise Time

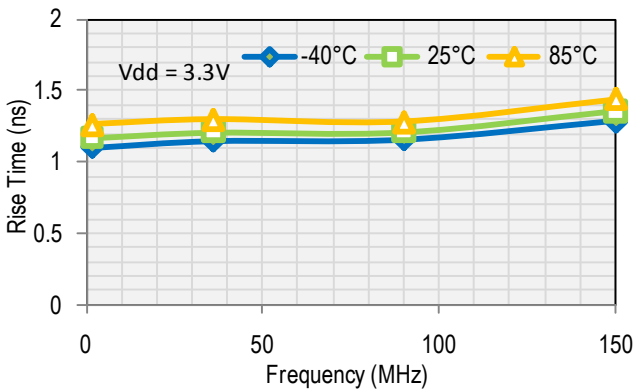

Fall Time

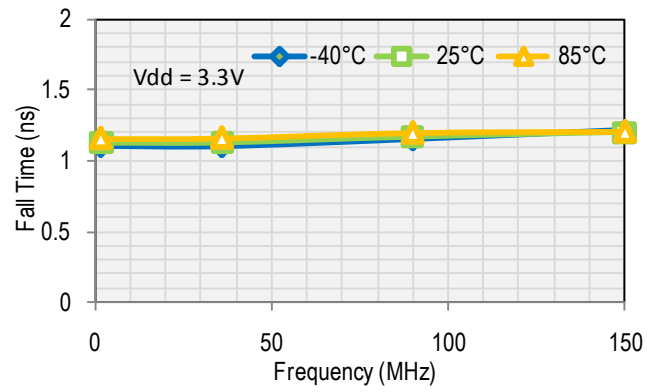

Rise Time

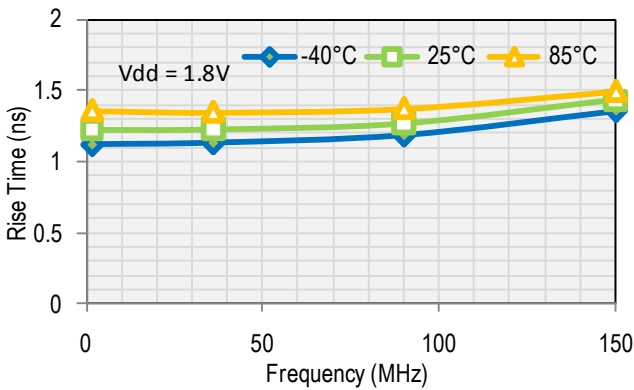

Fall Time

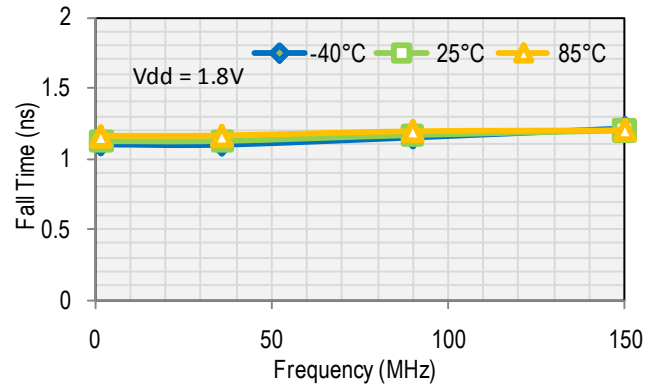

Output Waveform

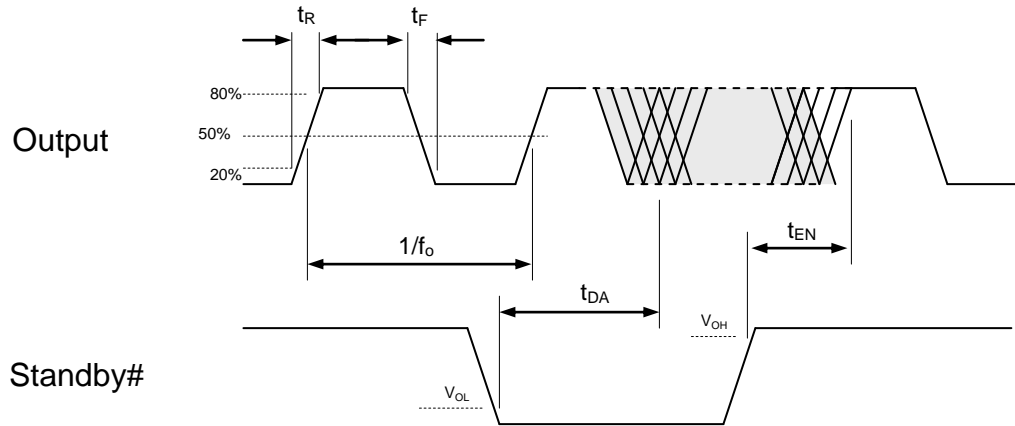

Standby Function

Standby# (pin 1)	Output (pin 3)
Hi Level	Output ON
Open (no connect)	Output ON
Low Level	High Impedance

Test Circuit

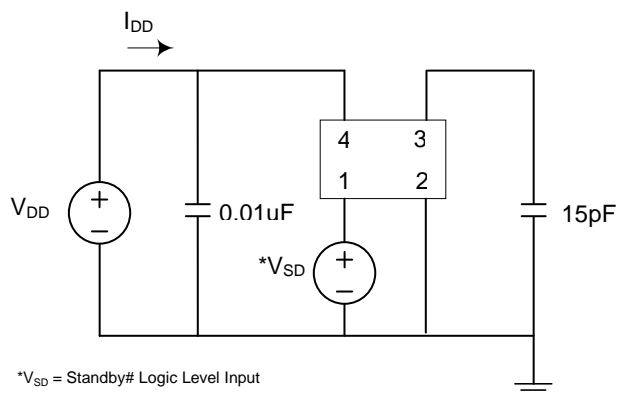

Board Layout (recommended)

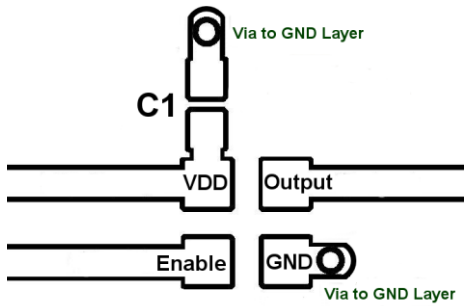

Solder Reflow Profile

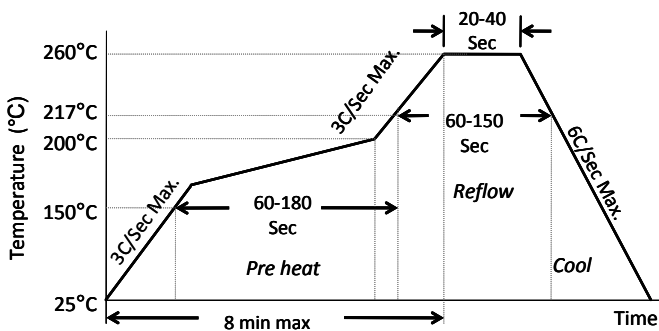

MSL 1 @ 260°C refer to JSTD-020C	
Ramp-Up Rate (200°C to Peak Temp)	3°C/Sec Max.
Preheat Time 150°C to 200°C	60-180 Sec
Time maintained above 217°C	60-150 Sec
Peak Temperature	255-260°C
Time within 5°C of actual Peak	20-40 Sec
Ramp-Down Rate	6°C/Sec Max.
Time 25°C to Peak Temperature	8 min Max.

Package Dimensions

7.0 x 5.0 mm Plastic Package

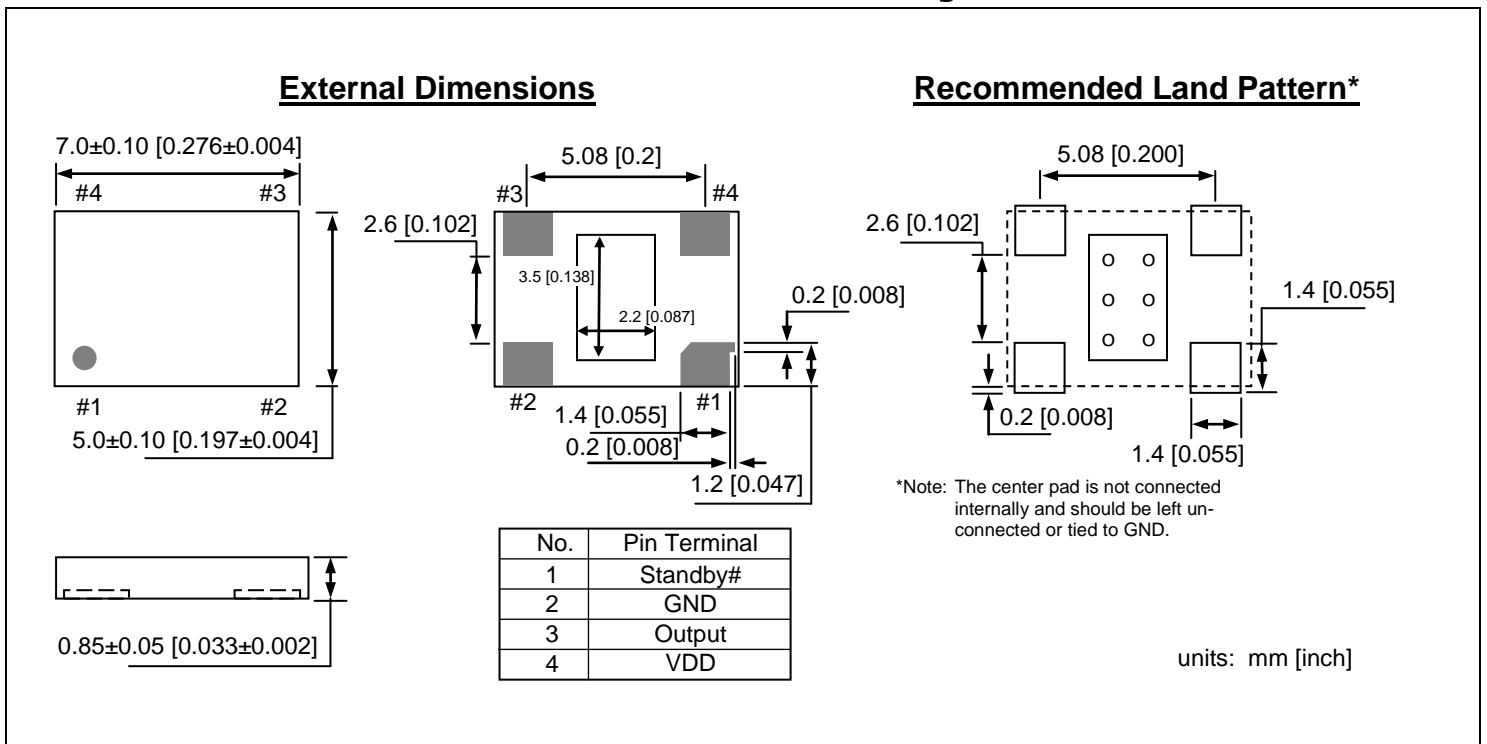

5.0 x 3.2 mm Plastic Package

External Dimensions

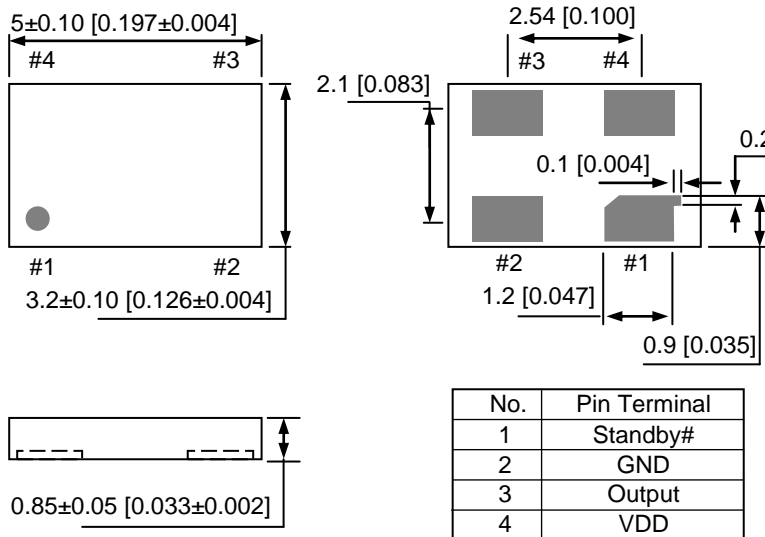

Recommended Land Pattern

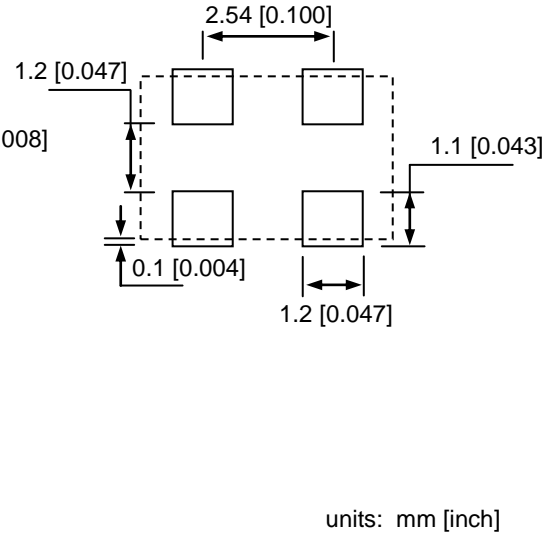

3.2 x 2.5 mm Plastic Package

External Dimensions

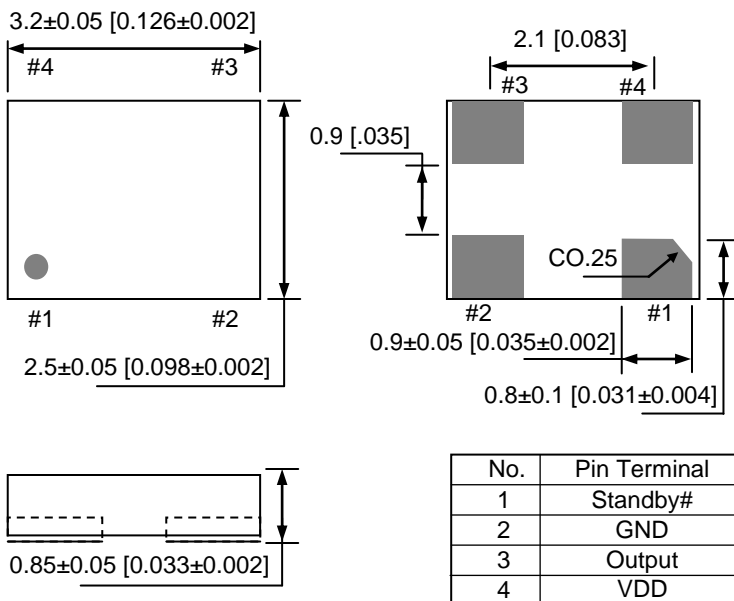

Recommended Land Pattern

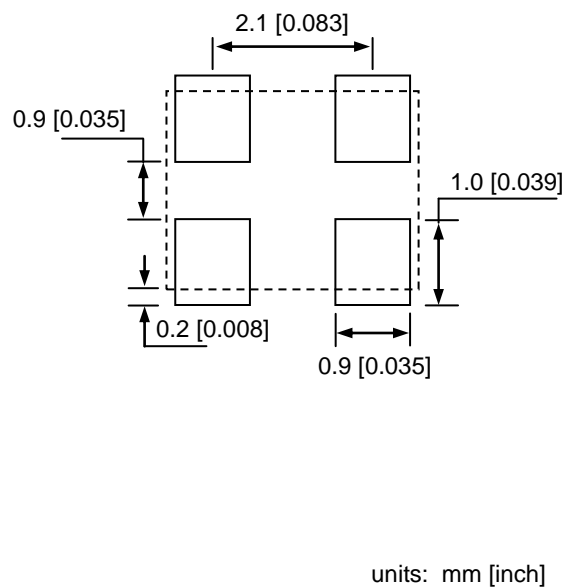

2.5 x 2.0 mm Plastic Package

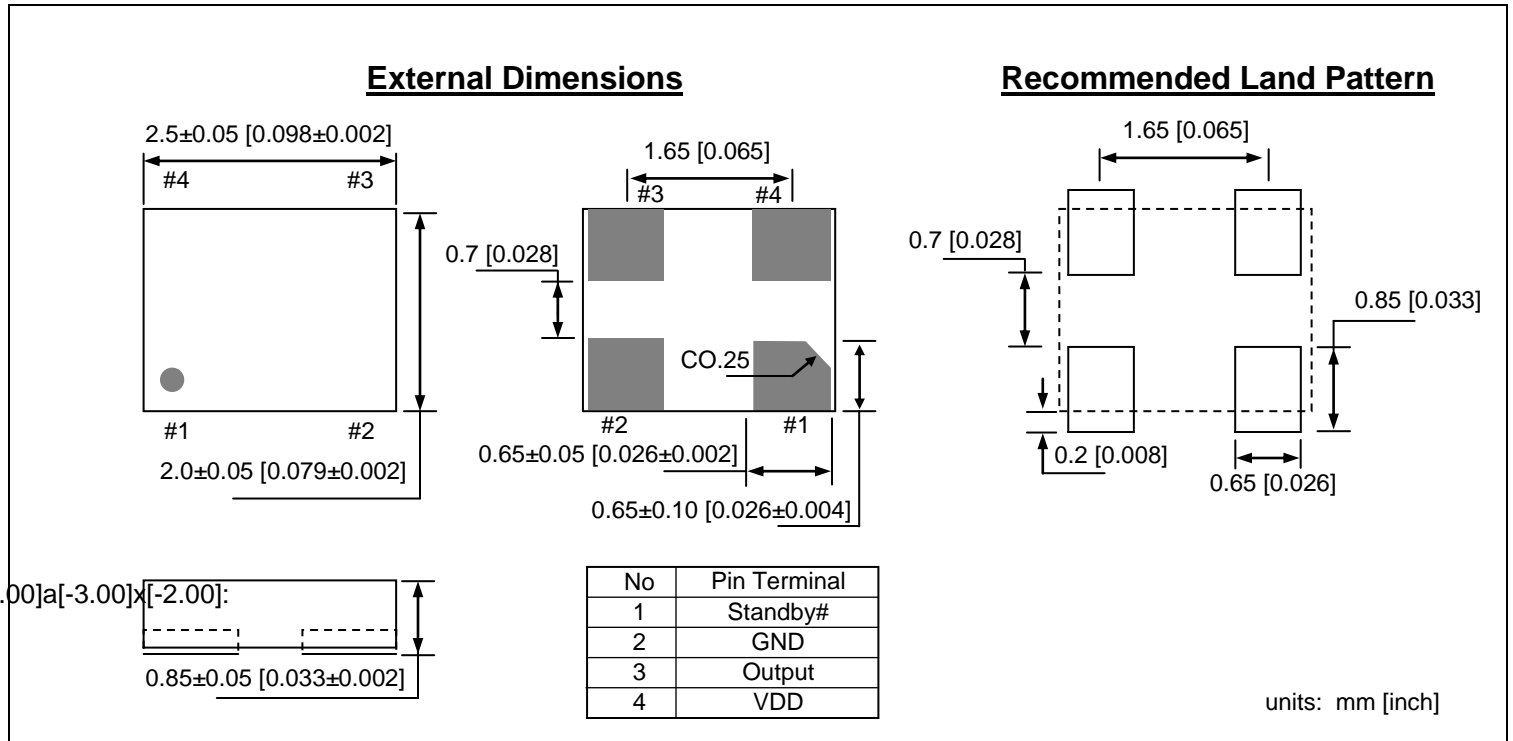

Ordering Information

DSC1001 PTS – xxx.xxxx T

PART NUMBERING GUIDE				
Package (Plastic QFN)	Temperature	Stability	Frequency	Packing Option
P=A: 7.0x5.0mm P=B: 5.0x3.2mm P=C: 3.2x2.5mm P=D: 2.5x2.0mm	T=C: 0° ~ +70° C T=E: -20° ~ +70° C T=I: -40° ~ +85° C T=L: -40° ~ +105° C	S=1: ±50ppm S=2: ±25ppm S=5: ±10ppm	XXX.XXXX (4 decimal places)	Blank: Tubes T: Tape & Reel

Example: DSC1001CE1-123.0000T

The example part number above is a 123.0000MHz oscillator in Plastic 3.2x2.5mm package, with ±50ppm stability over an operating temperature of -20 to +70°C, shipped in Tape and Reel.

SHENBEN YANG XING TECHNOLOGY CO., LTD.

Tel: +86 -755-28444777

Phone: +86 1341879 6700

Fax: +86 -755-83696007 • Email: xander@yangxing.hk

• DISCERA

• www.fxyg86.cn.alibaba.com