

GPS Engine Board

Gstar—GS-87



N 23.13044.
E 113.32230.

Guang Zhou Xin TU Technology, Inc.

Fax: 020-87598610 [Http://www.gzxintu.com](http://www.gzxintu.com)

TEL : 020-85667648.85667948.85660812.85660813 FAX:020-85667648-12

TABLE OF CONTENTS

1. Introduction	3
2. Main Feature	4
3. Technical Specifications	5
3.1. Electrical Characteristics	5
3.2. Environmental Characteristics	6
3.3. Physical Characteristics	6
4. Software Interface	7
4.1 NMEA Transmitted Messages	7
4.2 RTCM Received Data	13
4.3 . Manufacturing Default:	14
5. Mechanical Dimensions	15
5.1 . GS-87-T0A, GS-87-T0C outline:	15
5.2 . GS-87-T0B, GS-87-T0D outline:	16
5.3 . Pin assignment of connector :	17
6. Operation and Test	19
7. Ordering Information	22
7.1 Products Options	22
7.2 Accessories	22
7.3 Other Products	22
Appendix A : Reference Design	23
Appendix B : Connector	23

1.Introduction

The GS-87 series consists of SiRF star III chipsets technology, LNA and proprietary software. The system function block is described as follows.

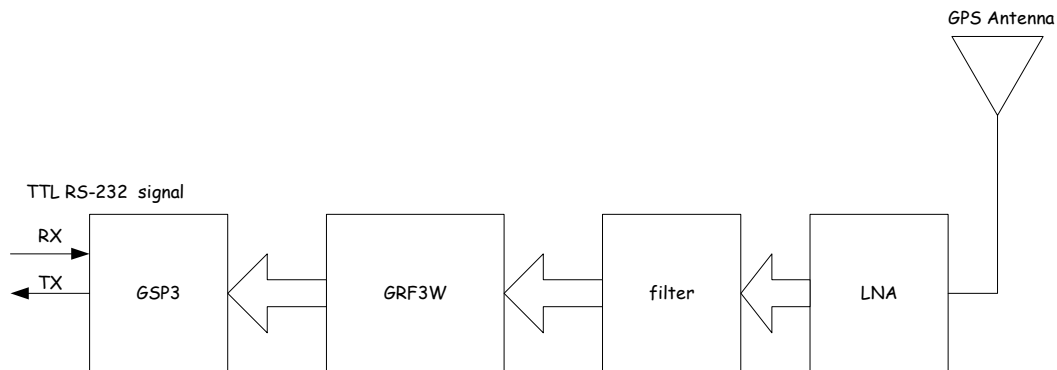

Gstar GS-87 is a high performance, low power consumption, small size, very easy integrated GPS engine board designed for a broad spectrum of OEM system applications. This product is based on the proven technology found in other Gstar 20 channel GPS receivers and SiRFstar III chipset solution. The GPS engine board will track up to 12 satellites at a time while providing fast time-to-first-fix and one-second navigation updates. Its far reaching capability meets the sensitivity requirements of car navigation as well as other location-based applications. Therefore, Gstar GS-87 engine board is very fit to the customers who devote themselves to AVL system integration and location-based service.

The GS-87 design utilizes the latest surface mount technology (BGA) and high level circuit integration to achieve superior performance while minimizing space and power requirements. This hardware capability combined with software intelligence makes the board easy to be integrated and used in all kinds of navigation applications or products. The application system may communicate with the engine board set via two RS232 compatible bi-directional communication channels with CMOS/CMOS 3V voltage level.

2. Main Feature

- Build on high performance SiRF StarIII chipset.
- Average Cold Start time and under 45 seconds.
- Low power consumption
- 20 channels “All-in-View” tracking.
- 200,000+ effective correlators for fast TTFF and high sensitivity acquisitions
- Integrated ARM7TDMI CPU with software engineering services and available for embedded customer defined applications.
- On chip 1Mb SRAM.
- Dual CMOS 3V level serial ports with one for GPS receiver command message interface, another one for RTCM-104 DGPS input.
- Compact Board Size 1”x1”x0.27”(25.4x25.4x7mm) for easy integration into hand-held device.
- Reacquisition Time 0.1 seconds
- Support Standard NMEA-0183 and SiRF Binary protocol
- Support Accurate 1PPS Output Signal Aligned with GPS Timing
- Multi-path Mitigation Hardware
- On-board RTCM SC-104 DGPS and WAAS /EGNOS Demodulator
- Built-in a lithium battery make GPS fast positioning

3. Technical Specifications

3.1. Electrical Characteristics

3.1.1 General

- 1). Frequency : L1, 1575.42 MHz.
- 2). C/A code : 1.023 MHz chip rate.
- 3). Channels : 20.

3.1.2 Accuracy (Open Sky)

- 1). Position : 10 meters, 2D RMS.
- 2). 7 meters 2D RMS, WAAS corrected.
- 3). 1-5 meters, DGPS corrected.
- 4). Altitude : $< \pm 35\text{m}$ Vertical in term of 95%.
- 5). Velocity : 0.1 meters/second.
- 6). Time 1 microsecond synchronized to GPS time.

3.1.3 Datum

- 1). Default : WGS-84.
- 2). Other Support different datum by request.

3.1.4 Acquisition Rate (Open sky, stationary requirements)

- 1). Reacquisition : 0.1 sec., average.
- 2). Hot start : 1 sec., average.
- 3). Warm start : 38 sec., average.
- 4). Cold start : 42 sec., average.

3.1.5 Dynamic Conditions

- 1). Altitude : 18,000 meters (60,000 feet)max.
- 2). Velocity : 515 meters/second (1000 knots) max.
- 3). Acceleration : 4g, max.
- 4). Jerk : 20 meters/second, max.

3.1.6 Power

- 1). Input power input : 3.3~5.5 VDC input.
- 2). Input current: Less than 80 mA (without antenna) .
- 3). Backup power: 3V Rechargeable Lithium cell battery, up to 500 hours discharge.

3.1.7 RF interface

- 1). Antenna connector type: MMCX, 2.8 VDC output. (optional output VCC_IN)
- 2). Minimum signal tracked: -159 dBm.

3.1.8 Serial Port

- 1). Two full duplex serial communication, CMOS 3V interface, with user selectable baud rate (4800-Default, 9600, 19200, 38400).
- 2). NMEA 0183 Version 2.2 ASCII output (GGA, GSA, GSV, RMC (VTG , GLL and ZDA for optional)).
- 3). DGPS protocol RTCM SC-104 message types 1, 2 and 9.
- 4). SiRF binary-position, velocity, altitude, status output.

3.1.9 TIMEMARK-1PPS Pulse

- 1). Level CMOS 3V.
- 2). Pulse duration 1 microsecond.
- 3). Time reference At the pulse positive edge.
- 4). Measurements Aligned to GPS second, ± 1 microsecond.

3.2. Environmental Characteristics

- 1). Operating temperature range -40°C to $+85^{\circ}\text{C}$.
- 2). Storage temperature range -40°C to $+125^{\circ}\text{C}$.

3.3. Physical Characteristics

- 1) Active Size: 25.4(W) x 25.4(D) x 7(H) (mm) .
- 2) Weight: 7 g.
- 3) Interface connector 6-pin straight male header, 1.25 mm pitch .
(Please refer to the appendix B)

4. Software Interface

The GS-87 interface protocol is based on the National Marine Electronics Association's NMEA 0183 ASC II interface specification, which is defined in NMEA 0183, Version 2.2 and the Radio Technical Commission for Maritime Services (RTCM Recommended Standards For Differential Navstar GPS Service, Version 2.1, RTCM Special Committee No.104).

As soon as the initial self-test is complete, the GS-87 begins the process of satellite acquisition and tracking automatically. Under normal circumstances, it takes approximately 45 seconds to achieve a position fix, 38 seconds if ephemeris data is known. After a position fix has been calculated, information about valid position, velocity and time is transmitted over the output channel.

The GS-87 utilizes initial data, such as last stored position, date, time and satellite orbital data, to achieve maximum acquisition performance. If significant inaccuracy exists in the initial data, or the orbital data is obsolete, it may take more time to achieve a navigation solution. The GS-87 Auto-locate feature is capable of automatically determining a navigation solution without intervention from the host system. However, acquisition performance can be improved as the host system initializes the GS-87 in the following situation:

- Moving further than 500 kilometers.
- Failure of Data storage due to the inactive internal memory battery.

4.1 NMEA Transmitted Messages

The default communication parameters for NMEA output are 4800 baud, 8 data bits, stop bit, and no parity.

Table 4-1 NMEA-0183 Output Messages

NMEA Record	Description
GPGGA	Global positioning system fixed data
GPGLL	Geographic position- latitude/longitude
GPGSA	GNSS DOP and active satellites
GPGSV	GNSS satellites in view
GPRMC	Recommended minimum specific GNSS data

GPVTG	Course over ground and ground speed
GPMSS	Radio-beacon Signal-to-noise ratio, signal strength, frequency, etc.
GPZDA	PPS timing message (synchronized to PPS)

4.1.1 Global Positioning System Fix Data (GGA)

Table 4-2 contains the values for the following example:

```
$GPGGA,161229.487,3723.2475,N,12158.3416,W,1,07,1.0,9.0,M,, , ,0000*18
```

Table 4-2 GGA Data Format

Name	Example	Units	Description
Message ID	\$GPGGA		GGA protocol header
UTC Time	161229.487		hhmmss.sss
Latitude	3723.2475		ddmm.mmmm
N/S Indicator	N		N=north or S=south
Longitude	12158.3416		dddmm.mmmm
E/W Indicator	W		E=east or W=west
Position Fix Indicator	1		See Table 5-3
Satellites Used	07		Range 0 to 12
HDOP	1.0		Horizontal Dilution of Precision
MSL Altitude (1)	9.0	Meters	
Units	M	Meters	
Geoid Separation(1)		Meters	
Units	M	Meters	
Age of Diff. Corr.		second	Null fields when DGPS is not used
Diff. Ref. Station ID	0000		
Checksum	*18		
<CR> <LF>			End of message termination

(1). SiRF Technology Inc. does not support geoid corrections. Values are WGS84 ellipsoid heights.

Table 4-3 Position Fix Indicator

Value	Description
0	0 Fix not available or invalid
1	GPS SPS Mode, fix valid
2	Differential GPS, SPS Mode, fix valid

3	GPS PPS Mode, fix valid
---	-------------------------

4.1.2 Geographic Position with Latitude/Longitude(GLL)

Table 4-4 contains the values for the following example:

\$GPGLL,3723.2475,N,12158.3416,W,161229.487,A*2C

Table 4-4 GLL Data Format

Name	Example	Units	Description
Message ID	\$GPGLL		GLL protocol header
Latitude	3723.2475		ddmm.mmmm
N/S Indicator	N		N/S Indicator N N=north or S=south
Longitude	12158.3416		dddmm.mmmm
E/W Indicator	W		E=east or W=west
UTC Position	161229.487		hhmmss.sss
Status	A		A=data valid or V=data not valid
Checksum	*2C		
<CR> <LF>			End of message termination

4.1.3 GNSS DOP and Active Satellites (GSA)

Table 4-5 contains the values for the following example:

\$GPGSA,A,3,07,02,26,27,09,04,15, , , , , ,1.8,1.0,1.5*33

Table 4-5 GSA Data Format

Name	Example	Units	Description
Message ID	\$GPGSA		GSA protocol header
Mode 1	A		See Table 5-6
Mode 2	3		See Table 5-7
Satellite Used(1)	07		Sv on Channel 1
Satellite Used(1)	02		Sv on Channel 2
.....		
Satellite Used(1)			Sv on Channel 12
PDOP	1.8		Position Dilution of Precision
HDOP	1.0		Horizontal Dilution of Precision
VDOP	1.5		Vertical Dilution of Precision

Checksum	*33		
<CR> <LF>			End of message termination

1. Satellite used in solution.

Table 4-6 Mode 1

Value	Description
M	Manual—forced to operate in 2D or 3D mode
A	2DAutomatic—allowed to automatically switch 2D/3D

Table 4-7 Mode 2

Value	Description
1	Fix Not Available
2	2D
3	3D

4.1.4 GNSS Satellites in View (GSV)

Table 4-8 contains the values for the following example:

\$GPGSV,2,1,07,07,79,048,42,02,51,062,43,26,36,256,42,27,27,138,42*71

\$GPGSV,2,2,07,09,23,313,42,04,19,159,41,15,12,041,42*41

Table 4-8 GSV Data Format

Name	Example	Units	Description
Message ID	\$GPGSV		GSV protocol header
Number of Messages(1)	2		Range 1 to 3
Message Number(1)	1		Range 1 to 3
Satellites in View	07		
Satellite ID	07		Channel 1 (Range 1 to 32)
Elevation	79	degrees	Channel 1 (Maximum 90)
Azimuth	048	degrees	Channel 1 (True, Range 0 to 359)
SNR (C/No)	42	dBHz	Range 0 to 99, null when not tracking
....		
Satellite ID	27		Channel 4 (Range 1 to 32)
Elevation	27	degrees	Channel 4 (Maximum 90)
Azimuth	138	degrees	Channel 4 (True, Range 0 to 359)

SNR (C/No)	42	dBHz	Range 0 to 99, null when not tracking
Checksum	*71		
<CR> <LF>			End of message termination

(1). Depending on the number of satellites tracked multiple messages of GSV data may be required.

4.1.5 Recommended Minimum Specific GNSS Data (RMC)

Table 4-9 contains the values for the following example:

\$GPRMC,161229.487,A,3723.2475,N,12158.3416,W,0.13,309.62,120598, ,*10

Table 4-9 RMC Data Format

Name	Example	Units	Description
Message ID	\$GPRMC		RMC protocol header
UTC Time	161229.487		hhmmss.sss
Status	A		A=data valid or V=data not valid
Latitude	3723.2475		ddmm.mmmm
N/S Indicator	N		N=north or S=south
Longitude	12158.3416		dddmm.mmmm
E/W Indicator	W		E=east or W=west
Speed Over Ground	0.13	knots	
Course Over Ground	309.62	degrees	True
Date	120598		ddmmyy
Magnetic Variation ⁽¹⁾		degrees	E=east or W=west
Checksum	*10		
<CR> <LF>			End of message termination

(1). SiRF Technology Inc. does not support magnetic declination. All "course over ground" data are geodetic WGS84 directions.

4.1.6 Course Over Ground and Ground Speed (VTG)

Table 4-10 contains the values for the following example:

\$GPVTG,309.62,T, ,M,0.13,N,0.2,K*6E

Table 4-10 VTG Data Format

Name	Example	Units	Description
Message ID	\$GPVTG		VTG protocol header
Course	309.62	degrees	Measured heading
Reference	T		True
Course		degrees	Measured heading
Reference	M		Magnetic ⁽¹⁾
Speed	0.13	knots	Measured horizontal speed
Units	N		Knots
Speed	0.2	km/hr	Measured horizontal speed
Units	K		Kilometers per hour
Checksum	*6E		
<CR> <LF>			End of message termination

(1). SiRF Technology Inc. does not support magnetic declination. All "course over ground" data are geodetic WGS84 directions.

4.1.7 MSK Receiver Signal (MSS)

Table 4-11 contains the values for the following example:

\$GPMSS,55,27,318.0,100,*66

Table 4-11 MSS Data Format

Name	Example	Units	Description
Message ID	\$GPMSS	MSS	protocol header
Signal Strength	55	dB	dB SS of tracked frequency
Signal-to-Noise Ratio	27	dB	SNR of tracked frequency
Beacon Frequency	318.0	kHz	Currently tracked frequency
Beacon Bit Rate	100		100 bits per second
Checksum	66		
<CR> <LF>			End of message termination

Note – The MSS NMEA message can only be polled or scheduled using the MSK NMEA input message.

4.1.8 ZDA—SiRF Timing Message

Outputs the time associated with the current 1 PPS pulse. Each message will be output within a few hundred ms after the 1 PPS pulse is output and will tell the time of the pulse that just occurred.

Table 4-12 contains the values for the following example:

\$GPZDA,181813,14,10,2003,00,00*4F

Table 4-12 ZDA Data Format

Name	Example	Units	Description
Message ID	\$GPZDA		ZDA protocol header
UTC Time	181813		Either using valid IONO/UTC or estimated from default leap seconds
Day	14		01 TO 31
Month	10		01 TO 12
Year	2003		1980 to 2079
Local zone hour	00	knots	Offset from UTC (set to 00)
Local zone hour	00		Offset from UTC (set to 00)
Checksum	4F		
<CR> <LF>			End of message termination

4.2 RTCM Received Data

The default communication parameters for DGPS Input are 9600 baud, 8 data bits, stop bit, and no parity. Position accuracy of less than 5 meters can be achieved with the GPS-82 by using Differential GPS (DGPS) real-time pseudo-range correction data in RTCM SC-104 format, with message types 1,2, or 9. As using DGPS receiver with different communication parameters, GPS-82 may decode the data correctly to generate accurate messages and save them in battery-back SRAM for later computing.

4.3 . Manufacturing Default:

Parameter	Com A	Com B
Input Protocol	NMEA Binary	RTCM SC-104
Output Protocol	NMEA Binary	None
Baud Rate	4800	9600
Parity None	None	
Stop Bits	1	1
Data Bits	8	8
Datum:	WGS84.	
Protocol	GGA, GSA, GSV, RMC or by demand.	

4.3.1 Setting Syntax

Datum change syntax:

```
>DOS\Sirfprog /Fdataxx.dat -Px -Bx -Csh1
```

-Px: x is com port, 1= COM1 2 = COM2

-Bx: Baud rate, 4800, 9600, 19200 or 38400

Example:

Change Datum to WGS84,

```
Sirfprog /Fdata58.dat -P1 -B4800 -Csh1 <Entry>
```

After change datum, the new datum will keep in SRAM. If long time (more than 7 days) no power supplied to GS-87, user must resend datum to GS-87 when power on.

4.3.2 Addition Software

SiRFDemo is the Evaluation Receiver configuration and monitoring software provided with the GS-87. This software can be used to monitor real-time operation of the GS-87 Receiver, log data for analysis, upload new software to the Receiver, and configure the Receiver operation. See setup.pdf for more information on the use and operation of SiRFDemo software.

5. Mechanical Dimensions

5.1 . GS-87-T0A, GS-87-T0C outline:

- Picture

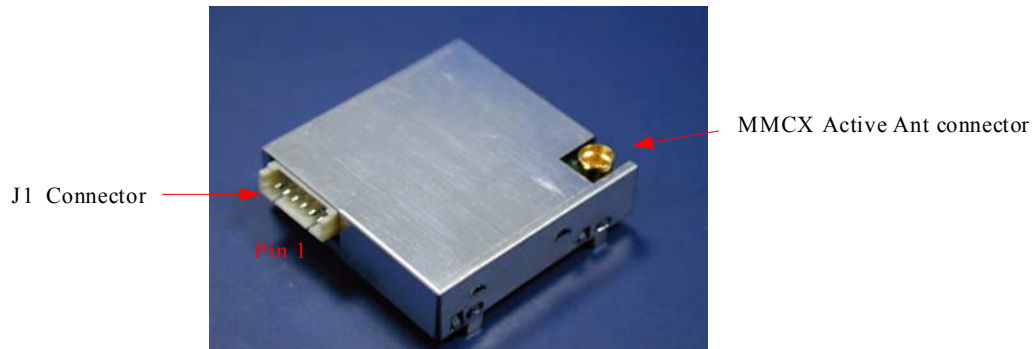

- Design Layout Diagram: (unit mm)

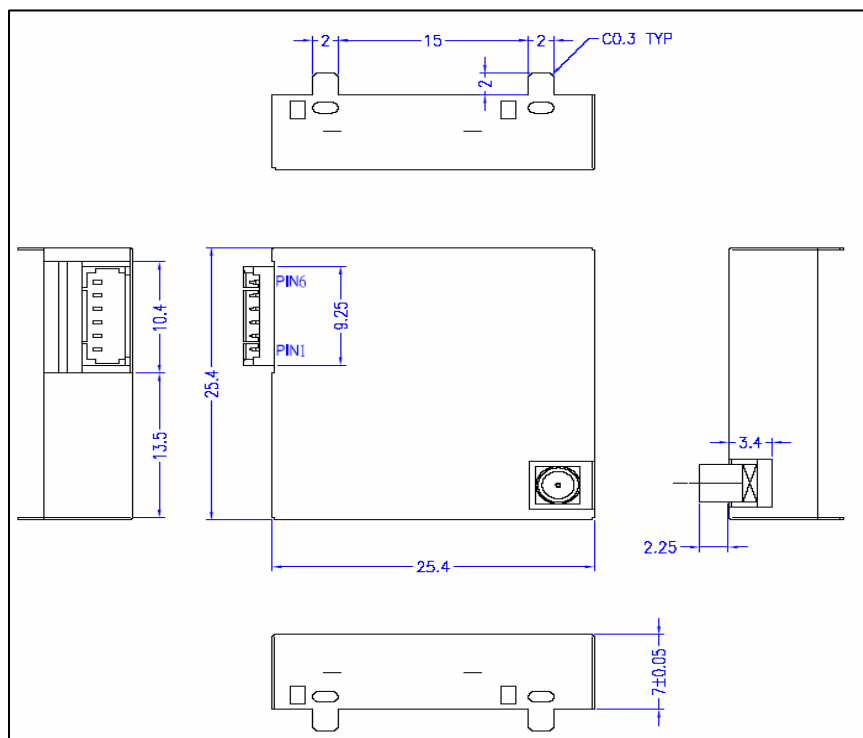

5.2 . GS-87-T0B, GS-87-T0D outline:

- Picture

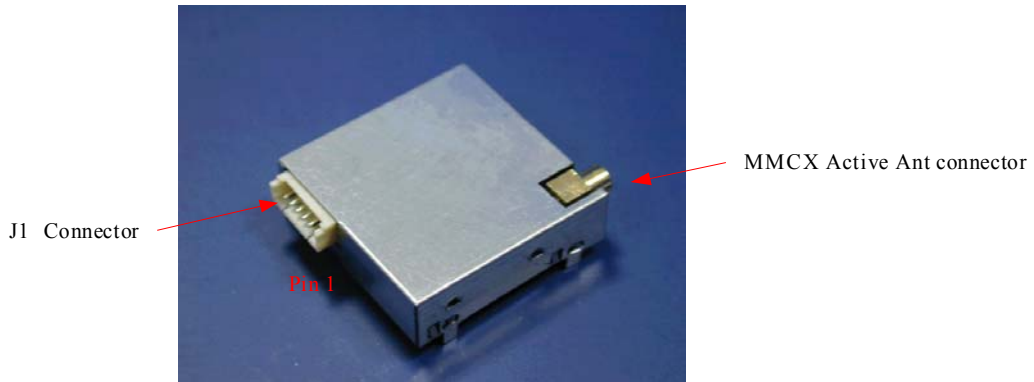

- Design Layout Diagram: (unit mm)

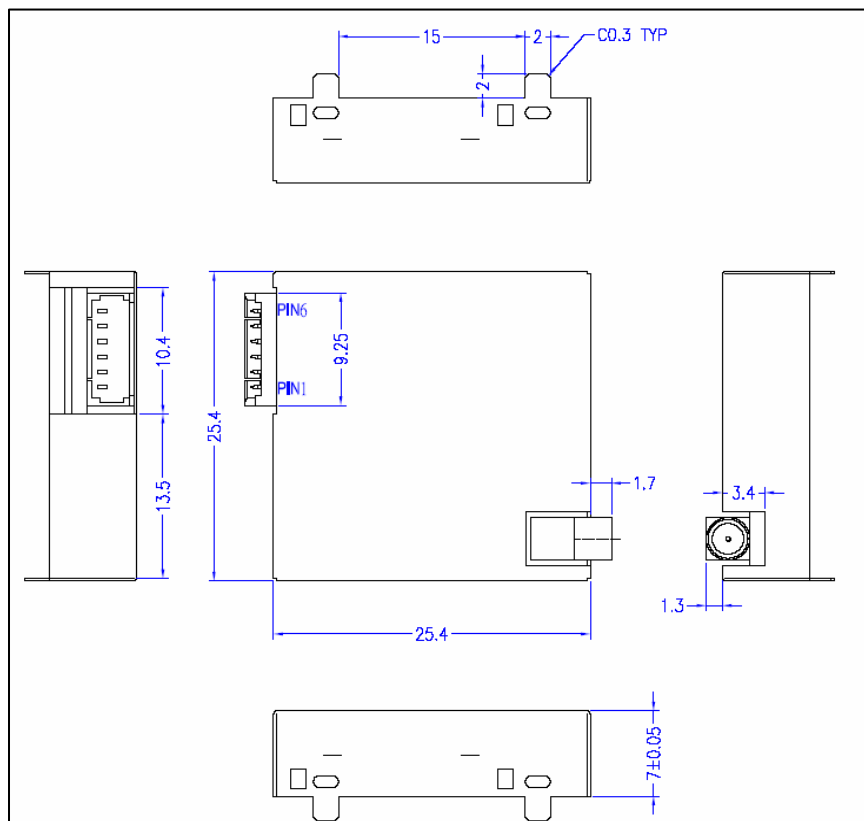

5.3 . Pin assignment of connector :

Table 5-1 is pin list of the 6-Pin Interface Connector. Connector is Male header 1.25mm pitch DIP R/A type. Actual pin size see appendix B.

Table 5-1 J1 connector pin definition:

Pin	Pin Name	Function description
1	VCC_5V	+3.3~5.5Vdc power input
2	TXA	Serial Data output port A(CMOS 3V Level: $V_{oh} \geq 2.4V$ $V_{ol} \leq 0.4V$ $I_{oh}=I_{ol}=2mA$)
3	RXA	Serial Data input port A(CMOS 3V Level $V_{ih} \geq 0.7*VCC$ $V_{il} \leq 0.3*VCC$)
4	RXB	Serial Data input port B(CMOS 3V Level $V_{ih} \geq 0.7*VCC$ $V_{il} \leq 0.3*VCC$)
5	GND	Power ground
6	TIMEMARK/ RESET (option)	TIMEMARK: 1PPS Time mark output($V_{il} \leq 0.2V$ Pulse Width 10ms). RESET: Reset Input (Active Low)(option function)

5.3.1 VCC_5V

This is the main DC power supply for a +3.3~ 5.5 V engine board.

5.3.2 TXA

This is the main transmitting channel and is used to output navigation and measurement data for user written software.

5.3.3 RXA

This is the main receiving channel and is used to receive software commands to the board from user written software.

5.3.4 RXB

This is the auxiliary receiving channel and is used to input differential corrections to the board to enable DGPS navigation.

5.3.5 GND

GND provides the ground for the board. Connect all grounds.

5.3.6 TIMEMARK (default)/ RESET (option)

This pin default is provides 1 pulse per second output from the GS-87 engine board, which is synchronized to within 1 microsecond of GPS time. The output is a CMOS 3V positive level signal. Only upon a situation of tracking or navigating will output once per second. This is not available in Trickle-Power mode.

The secondary option function is provides an active-low reset input to the engine board. It causes the engine board to reset and start searching for satellites. (This second function setting need contact factory).

6. Operation and Test

The customers can use Gstar GPSView.exe to test the engine board. GPSViewer.exe is compatible with Microsoft Pocket PC or other operation system alike.

- 1). Install Microsoft ActiveSync to your PC, refer to your Pocket PC manual for installation procedure, as Fig. 6.1.
- 2). Setup your Pocket PC cradle to Desktop PC UART port. The Microsoft ActiveSync will detect your Pocket PC automatically.

Setup your Pocket PC cradle to Desktop PC UART port. The Microsoft ActiveSync will detect your Pocket PC automatically, as Fig. 6.1.



(Fig. 6.1)

- 3). Double click the GPSViewer.exe on your PC, then Holux GPSViewer.exe program will install automatically, as Fig. 6.2.



(Fig. 6.2)

- 4) Open “GPSViewer” on PC, as Fig. 6.3.



(Fig. 6.3)

- 5) The following window is show after executing
6) GPSViewer, as Fig. 6.4.

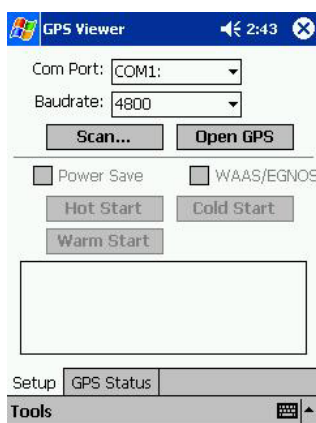

(Fig. 6.4)

- 7) Setup Baud rate: 4800, then push “Scan” bottom to scan your COM Port . Select your COM Port (COM1 ~ COM10), then push “Open GPN” bottom, as Fig. 6.5, Fig. 6.6, and Fig. 6.7.

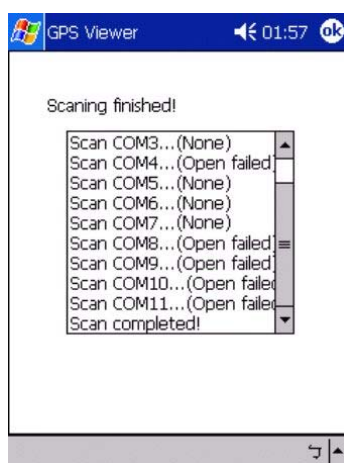

(Fig. 6.5)

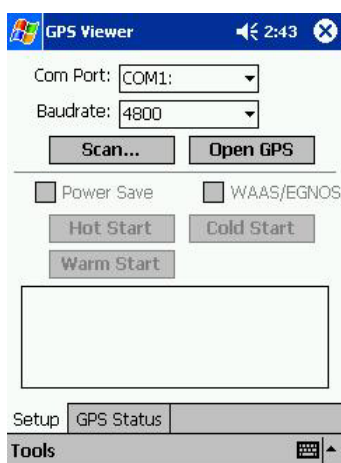

(Fig. 6.6)

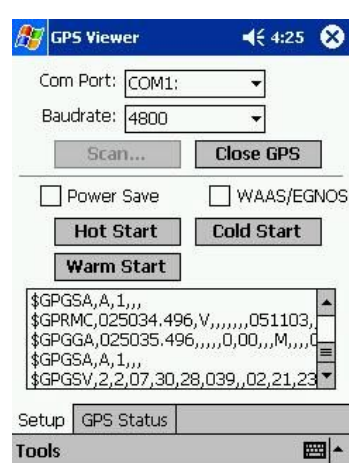

(Fig. 6.7)

8) Select "GPS Status" to show the satellite diagram like below, as Fig. 6.8.

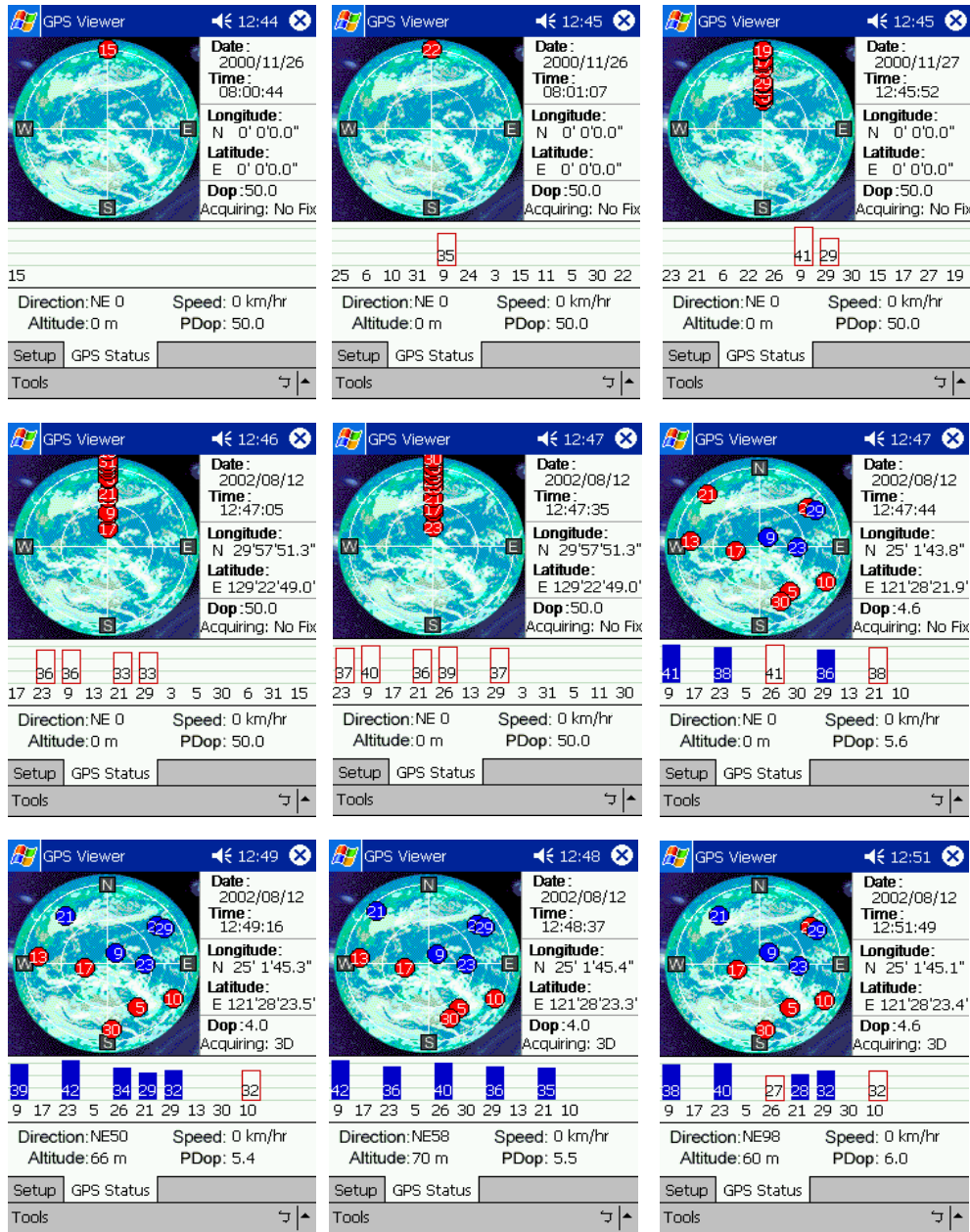

(Fig. 6.8)

7. Ordering Information

7.1 Products Options

Model No.	Output Level (CMOS 3V or RS-232)	RF interface output voltage (V)	Back-up battery (Rechargeable Lithium)	Power Saving	RF Connector Type
GS-87-T0A	CMOS 3V	2.8	Y	Y	MMCX(180°)
GS-87-T0B	CMOS 3V	2.8	Y	Y	MMCX(90°)
GS-87-T0C	CMOS 3V	VCC_IN	Y	Y	MMCX(180°)
GS-87-T0D	CMOS 3V	VCC_IN	Y	Y	MMCX(90°)

7.2 Accessories

Option Active antenna type.

Part No.	Cable length		Connector type(MMCX)	
	2 M	5M	90°	180°
68011-00	Y		Y	
68011-10		Y	Y	
68012-00	Y			Y
68012-10		Y		Y

Appendix A : Reference Design

Fig A-1 is GS-87 connects to RS-232 transceiver solutions intended for portable or hand-held applications such as notebook and palmtop computers.

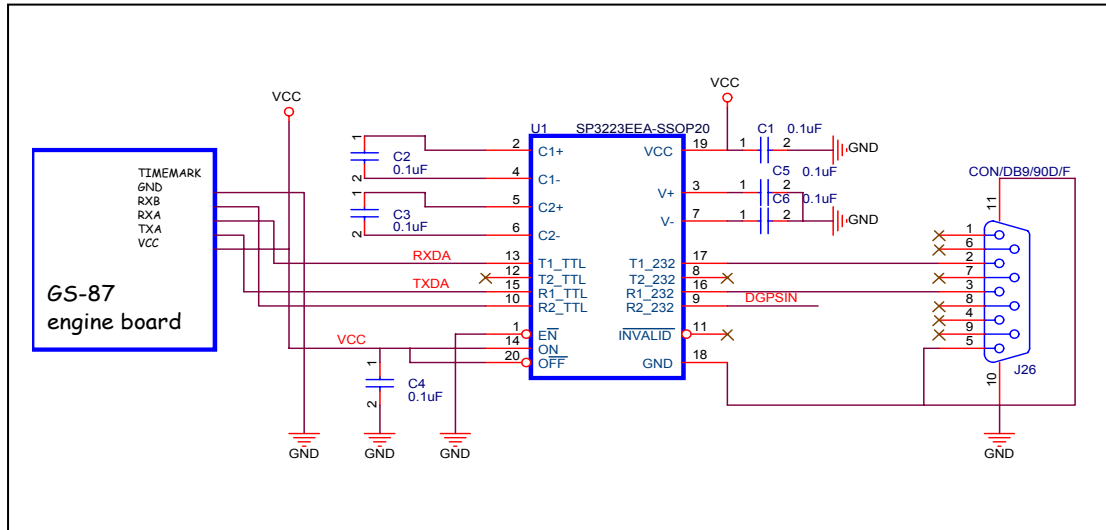

(Fig A-1)

Appendix B : Connector

- RF Connector . Type MMCX.

	Description:	Mmcx jack for P.C.B. mount.
	Gender:	Female
	Impedance:	50Ω
	Body Material:	Brass
	Contact Material:	Beryllium copper
	Finish:	Body Gold Contact Gold

- Interface connector: Male header 1.25mm pitch DIP R/A type.

