

## General description

The CC1101-433M RF module is low cost and highly integrated UHF transceiver designed for very low power wireless applications. These certified modules, operating in the license free 433 MHz ISM band, can be easily integrated into your application, thereby reducing development time and cost.

## Key features

- | Multi-channel transceiver @433MHz
- | Supports FSK, GFSK, ASK/OOK and MSK
- | Configurable data rates 1.2k to 500 kbps
- | Separate 64 byte RX and TX data FIFOs
- | Wake-on-Radio functionality
- | Digital RSSI output
- | Programmable Carrier Sense indicator
- | Programmable output power up to 10dBm
- | Optional Forward Error Correction function
- | Support automatic Clear Channel Assessment
- | SPI interface
- | Low power 1.8~3.6V supply
- | Small size only 17\*19\*2.4mm

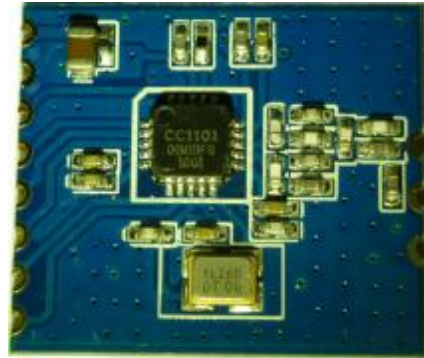

## Applications

- | Ultra low power UHF wireless transceivers
- | 315/433/868 and 915 MHz ISM/SRD band systems
- | Home and building automation
- | Wireless alarm and security systems
- | AMR – Automatic Meter Reading
- | Remote gate control
- | Car alarm system
- | Two-way RKE –Remote Keyless Entry
- | Low power telemetry
- | Industrial monitoring and control
- | Wireless sensor networks



### Electrical Characteristics

NO	TEST ITEM	TEST CRITERIA & REQUIREMENT	REMARKS
1	Modulation mode	ASK/ OOK /2-FSK/GFSK /MSK	
2	Center frequency	433MHz	Programmable
3	Frequency error	$\pm 10$ KHz	
4	Transmission power	-30~+10dBm(10mW)	Programmable
5	Receiving sensitivity	-110 ~ -112dBm	2.4Kdata rate.
6	Data rate	1.2-500Kbps	Programmable
7	Transmitting current	$\leq 30$ mA at 10dBm	$\leq 16$ mA at 0dBm
8	Receiving current	$\leq 20$ mA	
9	Sleeping current	$\leq 2$ uA	
10	Bandwidth	58-650KHz	26M Crystal
11	Reliable transmit distance	200M	at open area
12	Power supply	1.8-3.6VDC	
13	Operating temperature	-40°C ~85°C	

Ta = 25°C unless otherwise specified

Typically, equipment utilizing this device requires emissions testing and government approval, which is the responsibility of the equipment manufacture.

### The CC1101 RF module frequency spectrum

n The RF carrier test at 433MHz 10dBm, frequency error is  $\pm 10$ kHz Limi

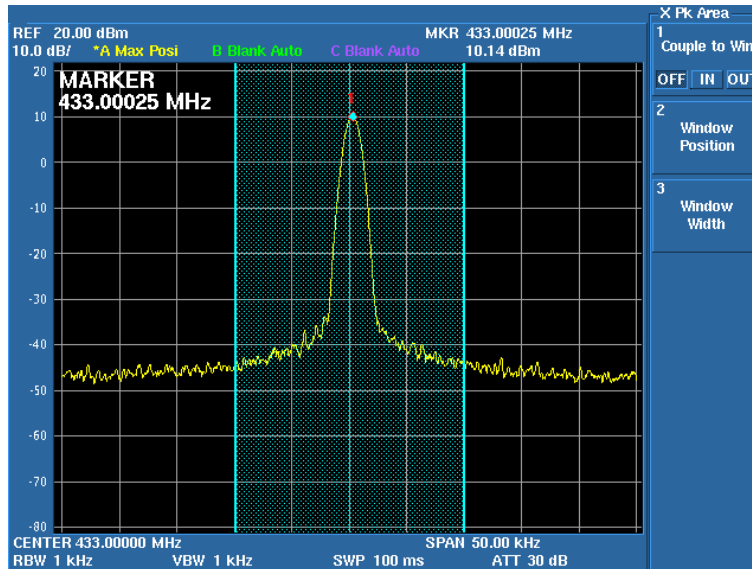

## Pin Assignment

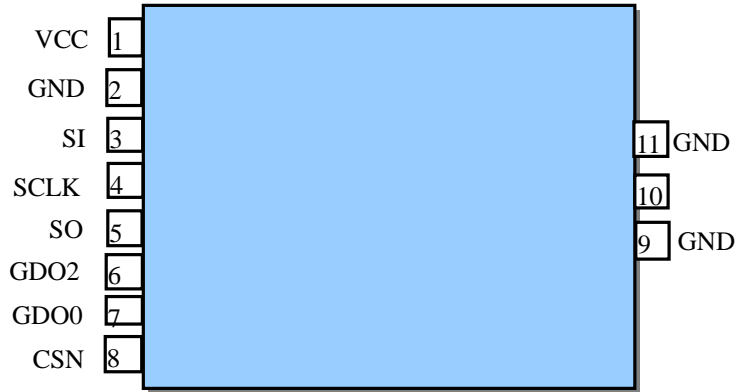

Pin name	Pin type	Description
VCC	Power	DC1.8-3.6V power supply
GND	Ground	
SI	Digital Input	Serial configuration interface, data input
SCLK	Digital Input	Serial configuration interface, data input
SO	Digital Output	Serial configuration interface, data output. Optional general output pin when CSn is high
GDO2	Digital Output	Digital output pin for general use: <ul style="list-style-type: none"> <li>• Test signals</li> <li>• FIFO status signals</li> <li>• Clear Channel Indicator</li> <li>• Clock output, down-divided from XOSC</li> </ul>
GDO0	Digital I/O	Digital output pin for general use: <ul style="list-style-type: none"> <li>• Test signals</li> <li>• FIFO status signals</li> <li>• Clear Channel Indicator</li> <li>• Clock output, down-divided from XOSC</li> <li>• Serial output RX data</li> </ul>
		• Serial output RX data

### Mechanical dimension and pad size (mm)

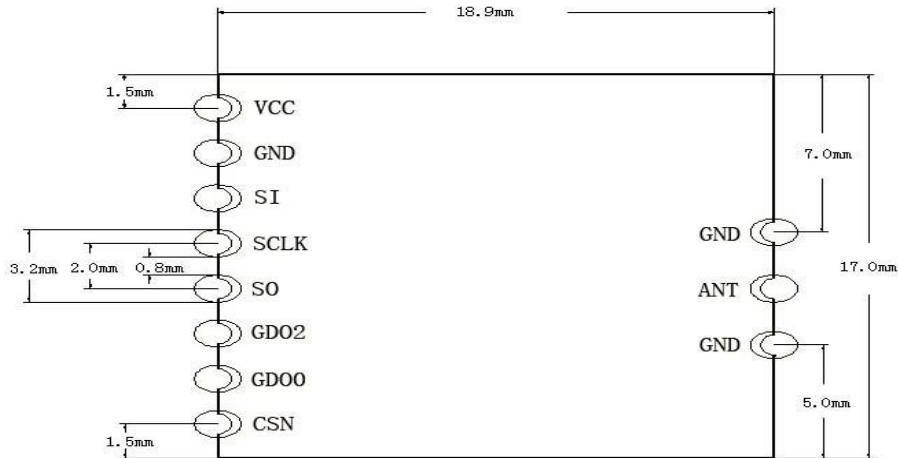

### Typical application circuit

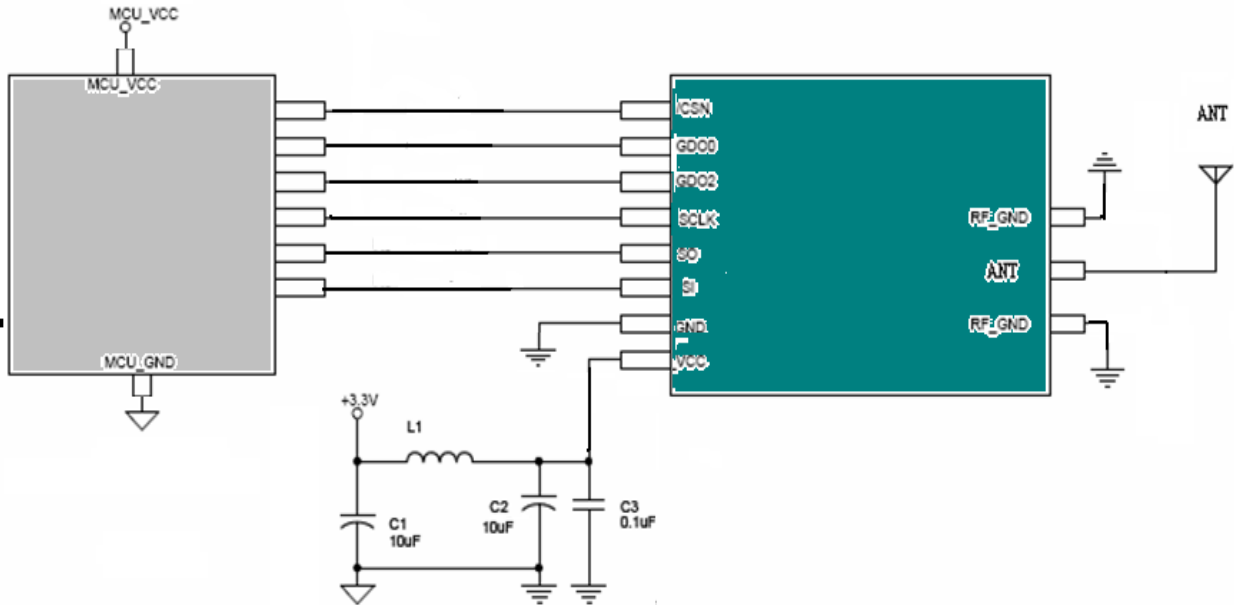

## PCB Layout reference design

