

500 mW DO-35 Hermetically Sealed Glass Zener Voltage Regulators



 AXIAL LEAD
DO35

Absolute Maximum Ratings $T_A = 25^\circ\text{C}$ unless otherwise noted

Parameter	Value	Units
Power Dissipation	500	mW
Storage Temperature Range	-65 to +200	$^\circ\text{C}$
Operating Junction Temperature	+200	$^\circ\text{C}$
Lead Temperature (1/16" from case for 10 seconds)	+230	$^\circ\text{C}$

These ratings are limiting values above which the serviceability of the diode may be impaired.

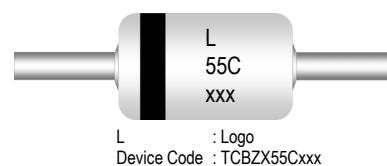
DEVICE MARKING DIAGRAM



Specification Features:

- Zener Voltage Range 3.3 to 56 Volts
- DO-35 Package (JEDEC)
- Through-Hole Device Type Mounting
- Hermetically Sealed Glass
- Compression Bonded Construction
- All external surfaces are corrosion resistant and leads are readily solderable
- Cathode indicated by polarity band

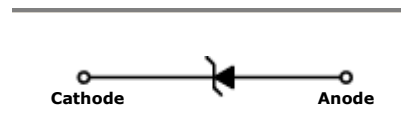

ELECTRICAL SYMBOL

Electrical Characteristics $T_A = 25^\circ\text{C}$ unless otherwise noted

Device Type	$V_Z @ I_{ZT}$ (Volts)		I_{ZT} (mA)	$Z_{ZT} @ I_{ZT}$ (Ω) Max	I_{ZK} (mA)	$Z_{ZK} @ I_{ZK}$ (Ω) Max	$I_R @ V_R$ (μA) Max	V_R (Volts)
	V_Z Min	V_Z Max						
TCBZX55C 3V3	3.1	3.5	5	85	1	600	2	1
TCBZX55C 3V6	3.4	3.8	5	85	1	600	2	1
TCBZX55C 3V9	3.7	4.1	5	85	1	600	2	1
TCBZX55C 4V3	4	4.6	5	75	1	600	1	1
TCBZX55C 4V7	4.4	5	5	60	1	600	0.5	1
TCBZX55C 5V1	4.8	5.4	5	35	1	550	0.1	1
TCBZX55C 5V6	5.2	6	5	25	1	450	0.1	1
TCBZX55C 6V2	5.8	6.6	5	10	1	200	0.1	2
TCBZX55C 6V8	6.4	7.2	5	8	1	150	0.1	3
TCBZX55C 7V5	7	7.9	5	7	1	50	0.1	5
TCBZX55C 8V2	7.7	8.7	5	7	1	50	0.1	6.2
TCBZX55C 9V1	8.5	9.6	5	10	1	50	0.1	6.8
TCBZX55C 10	9.4	10.6	5	15	1	70	0.1	7.5
TCBZX55C 11	10.4	11.6	5	20	1	70	0.1	8.2
TCBZX55C 12	11.4	12.7	5	20	1	90	0.1	9.1
TCBZX55C 13	12.4	14.1	5	26	1	110	0.1	10
TCBZX55C 15	13.8	15.6	5	30	1	110	0.1	11
TCBZX55C 16	15.3	17.1	5	40	1	170	0.1	12
TCBZX55C 18	16.8	19.1	5	50	1	170	0.1	13
TCBZX55C 20	18.8	21.1	5	55	1	220	0.1	15
TCBZX55C 22	20.8	23.3	5	55	1	220	0.1	16

Electrical Characteristics $T_A = 25^\circ\text{C}$ unless otherwise noted

Device Type	$V_Z @ I_{ZT}$ (Volts)		I_{ZT} (mA)	$Z_{ZT} @ I_{ZT}$ (Ω) Max	I_{ZK} (mA)	$Z_{ZK} @ I_{ZK}$ (Ω) Max	$I_R @ V_R$ (μA) Max	V_R (Volts)
	V_Z Min	V_Z Max						
TCBZX55C 24	22.8	25.6	5	80	1	220	0.1	18
TCBZX55C 27	25.1	28.9	5	80	1	220	0.1	20
TCBZX55C 30	28	32	5	80	1	220	0.1	22
TCBZX55C 33	31	35	5	80	1	220	0.1	24
TCBZX55C 36	34	38	5	80	1	220	0.1	27
TCBZX55C 39	37	41	2.5	90	0.5	500	0.1	28
TCBZX55C 43	40	46	2.5	90	0.5	600	0.1	32
TCBZX55C 47	44	50	2.5	110	0.5	700	0.1	35
TCBZX55C 51	48	54	2.5	125	0.5	700	0.1	38
TCBZX55C 56	52	60	2.5	135	0.5	1000	0.1	42

 V_F Forward Voltage = 1.0 V Maximum @ $I_F = 100$ mA for all types

Notes:

- The type numbers listed have zener voltage min/max limits as shown.
- For detailed information on price, availability and delivery of nominal zener voltages between the voltages shown and tighter voltage tolerances, contact your nearest Tak Cheong Electronics representative.
- The zener impedance is derived from the 60-cycle ac voltage, which results when an ac current having an rms value equal to 10% of the dc zener current (I_{ZT} or I_{ZK}) is superimposed to I_{ZT} or I_{ZK} .

Electrical Symbol Definition

Symbol	Parameter
V_Z	Reverse Zener Voltage @ I_{ZT}
I_{ZT}	Reverse Current
Z_{ZT}	Maximum Zener Impedance @ I_{ZT}
I_{ZK}	Reverse Current
Z_{ZK}	Maximum Zener Impedance @ I_{ZK}
I_R	Reverse Leakage Current @ V_R
V_R	Breakdown Voltage
I_F	Forward Current
V_F	Forward Voltage @ I_F

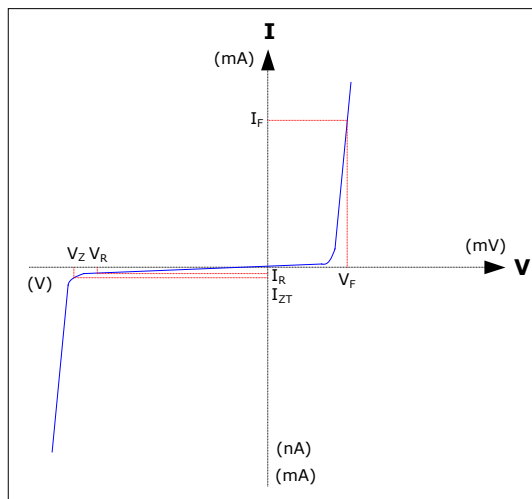
Typical Characteristics

Ordering Information

Device	Package	Quantity
TCBZX55Cxxx	Bulk	10,000
TCBZX55Cxxx.TB	Tape and Ammo	5,000
TCBZX55Cxxx.TR	Tape and Reel	10,000
TCBZX55Cxxx	Others (...contact Tak Cheong sales representatives)	

Axial-Lead Tape Packaging Standards

This axial-lead component's packaging requirements use in automatic testing and assembly equipment. And this standard practices for lead-tape packaging of axial-lead components meets the requirements of EIA Standard RS-296-D "Lead-taping of Components on Axial Lead Configuration for Automatic Insertion".

Tape & Reel Packaging Information

Tape & Reel Outline

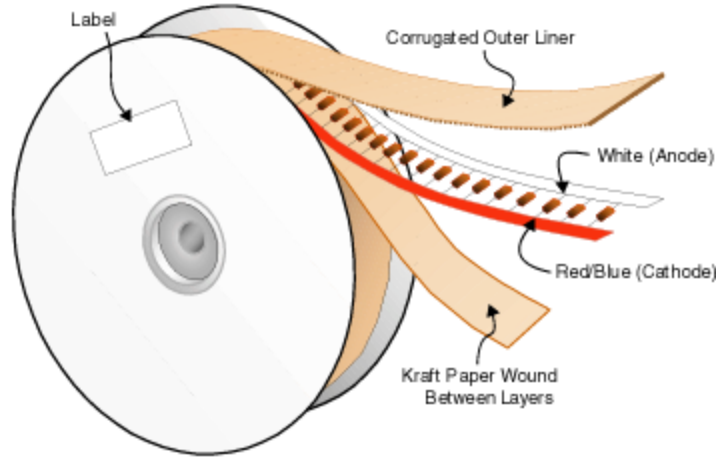

Reel Dimensions

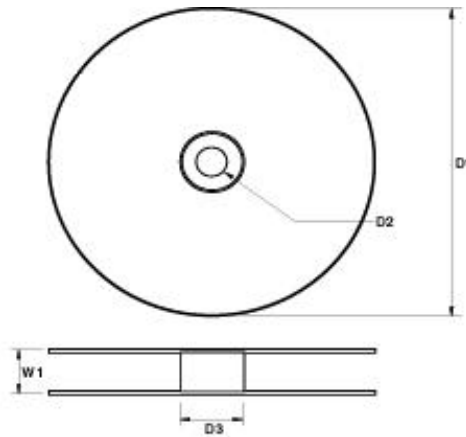

DIM	Millimeters
D1	356
D2	30
D3	84
W1	77.5

Quantity Per Reel

PKG Type	Quantity Per Reel
DO-35	10,000

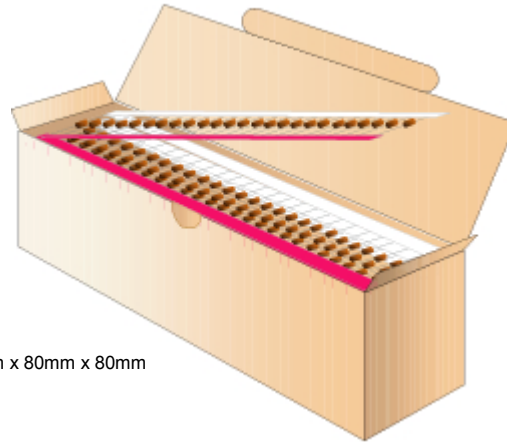
Tape & Ammo Packaging Information
Tape & Ammo Outline

250mm x 80mm x 80mm

Quantity Per Ammo Box

PKG Type	Quantity Per Box
DO-35	5,000

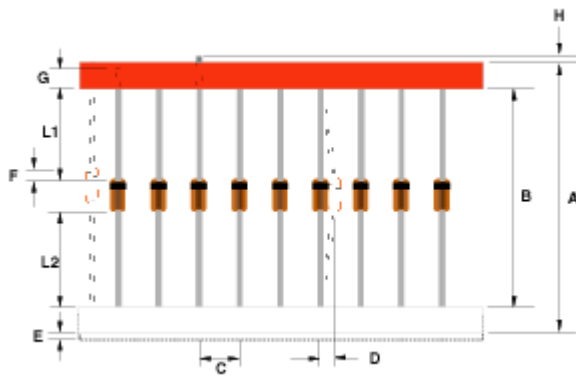
Taping Dimensions

Description	Millimeters	
	Standard Width	52
Tape Spacing (B)	52 ± 0.69	26 +0.5 / -0
Component Pitch (C)	5.08 ± 0.4	5.08 ± 0.4
Untaped Lead (L1 – L2)	± 0.69	± 0.69
Glass Offset (F)	± 0.69	± 0.69
Bent (D)	1.2 Max	1.2 Max
Tape Width (G)	6.138 ± 0.576	6.138 ± 0.576
Tape Mismatch (E)	0.55 Max	0.55 Max
Taped Lead (G)	3.2 Min	3.2 Min
Lead Beyond Tape (H)	0	0

Bulk Packaging Information

Bulk Outline

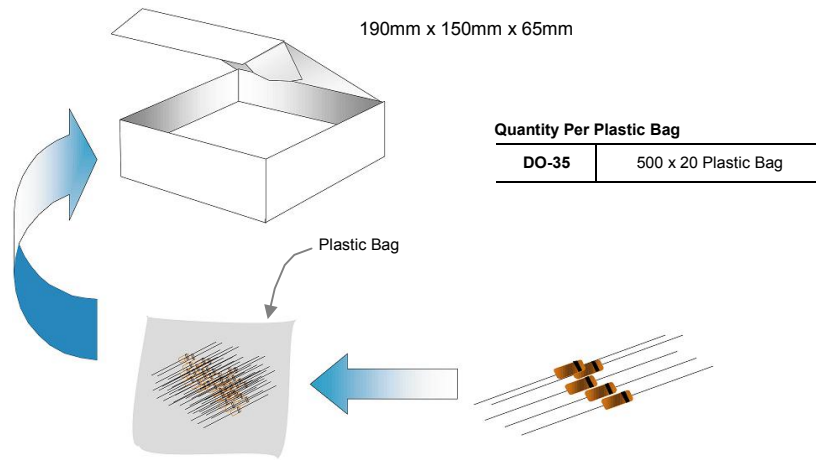

Quantity Per Box

PKG Type	Quantity Per Box
DO-35	10,000

Package Outline

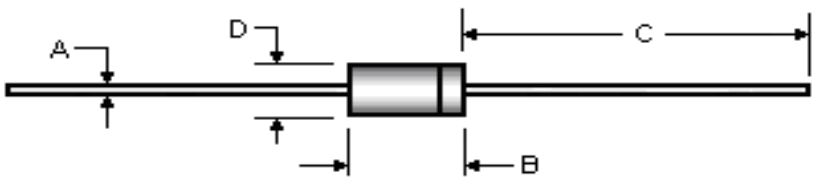
Package	Case Outline				
DO-35					
	DO-35				
	DIM	Millimeters		Inches	
		Min	Max	Min	Max
	A	0.46	0.55	0.018	0.022
	B	3.05	5.08	0.120	0.200
C	25.40	38.10	1.000	1.500	
D	1.53	2.28	0.060	0.090	

Notes:

1. All dimensions are within JEDEC standard.
2. DO35 polarity denoted by cathode band.