

PRODUCT TYPE

FOR-JAB090W-4222-18

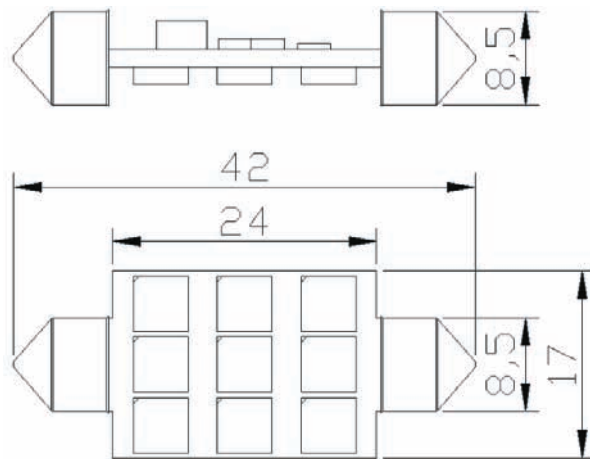
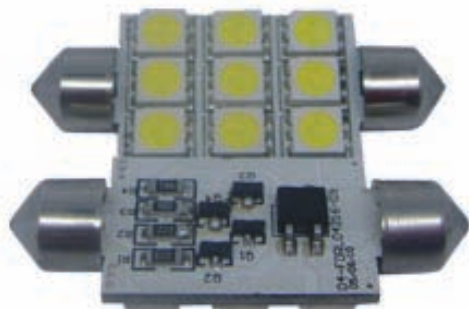

(Unit:mm)

DESCRIPTION

211 car festoon LED bulb 5050SMD*9PCS L42MM constant-current 11-18V White

A Electronics And Optical Characteristics: Ta=25°C

Emitting Color	Forward Voltage Unit:v	Totality Luminous flux Unit:LM	Single LED Intensity Unit:mcd	Dominant Wavelength Unit:nm	Viewing Angle Unit:deg	Color Temperature Unit:K
NW	12	90	4000-4500	---	120	4000-5000
WW	12	90	4000-4500	---	120	2700-3500
CW	12	90	4000-4500	---	120	6000-7000
Test Condition	Test Voltage: 12V		Current: 90mA±10%		Power: 1.08 W	
IR max: 10 μA/per chip			VR= 3.3V/per chip			

B Absolute Maximum Ratings AT Ta=25°C

PARAMETER	MAX	UNIT
Continuous Forward Current	20	mA/per chip
Peak Forward Current (1/10 Duty Cycle 0.1ms Pulse Width)	100	mA/per chip
Reverse Voltage	5	V/per chip
Operating Temperature Range	-30°C to +75°C	
Storage Temperature/Humidity Range	-40°C to +100°C (/40%to70%)	

Lead Solder Temperature 1.6mmBelow Package 260°C For 5 seconds

Usage: LED doom bulb, LED reading bulb, LED license plate bulb,...

Advantage: With high quality copper head, very durable, fast heat dissipation, good color rendering, high luminous efficiency, emitting color uniformity with 360 degree, compact good looks, the quantity SMD, length add or reduce to adjust the luminous to meet customers' requirements.

PACKAGE

FOR-JAB090W-4222-18

Package Dimensions (Unit:mm) :

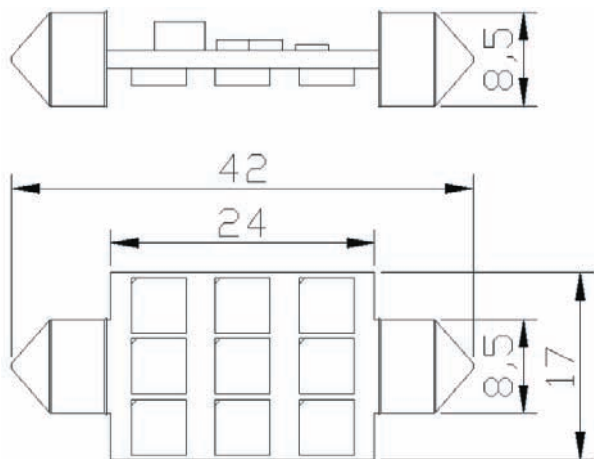

- Packaging: 30#Blister Card (1pcs)
- Net weight: 3. 6g
- Gross weight: 12. 5g
- Box size: 210*150*92mm
- Carton size: 440*320*310mm
- Packaging Quantity: 408pcs

1PCS/Blister



Blister

34Blister/ box

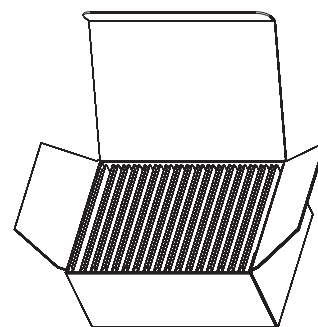

box size(L210*W150*H92MM)

12 boxes

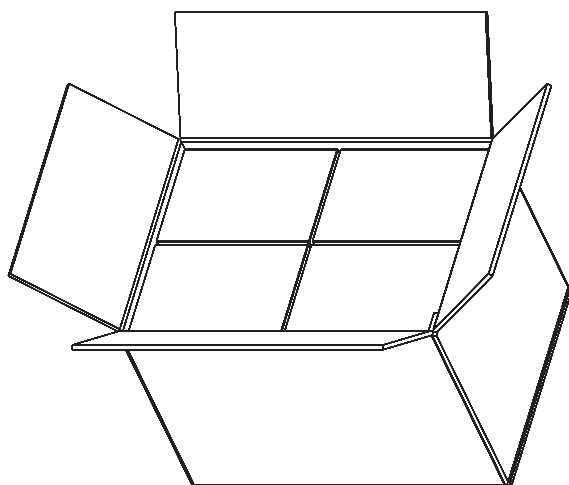

Carton(L440*W320*H310MM)

12 boxes/carton

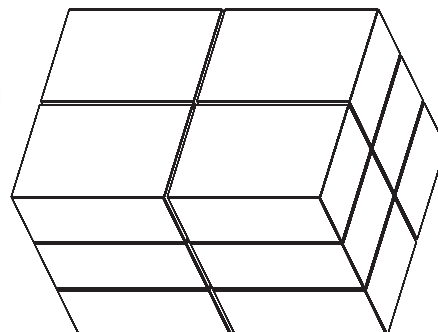

CONTACT US