

## 1.DIMENSION OUTLINE

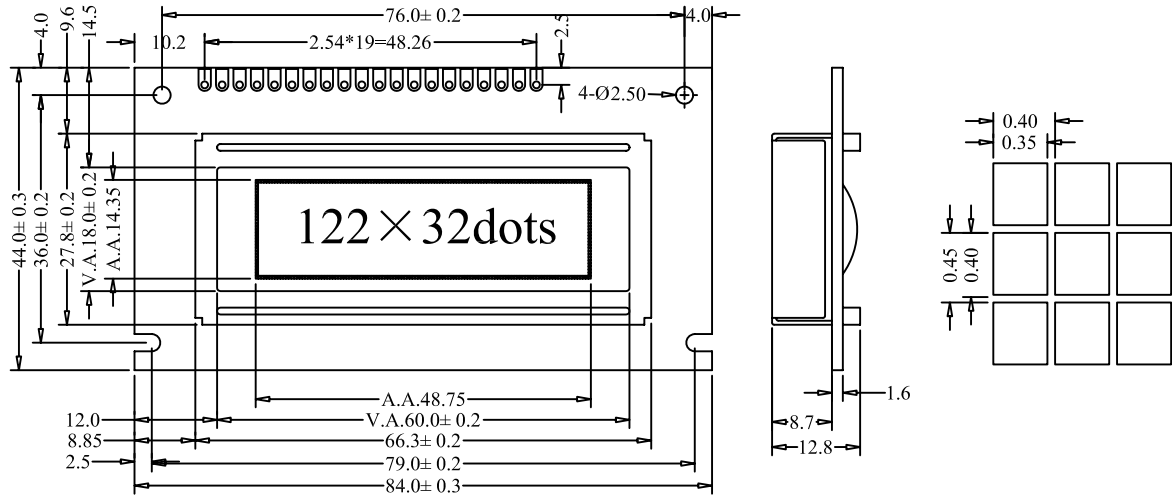

## 2.MECHANICAL SPECIFICATIONS

ITEM	SPECIFICATIONS	ITEM	REMARK
Module Size(L×W×H)	84.0×44.0×12.8	mm	Reference Dimensional Outline
View Area(W×H)	60.0×18.0	mm	
Effective V/Area(W×H)	48.75×14.35	mm	
Number of Dots	122×32	—	
Dot Pitch(W×H)	0.40×0.45	mm	
Dot Size(W×H)	0.35×0.40	mm	
Weigh(Reflective/LED)	—	g	

## 3.ABSOLUTE MAXIMUM RATINGS

ITEM	SYMBOL	CONDITION	STANDARD	
			MIN	MAX
Logic Voltage	V <sub>DD</sub>	Ta=25°C	-0.3V	7V
LCD Voltage	V <sub>LCD</sub>		-0.3V	13.5V
Input Voltage	V <sub>I</sub>		-0.3V	V <sub>DD</sub> +0.3V
Operation Temperature	T <sub>OP</sub>	—	-20°C	70°C
Storage Temperature	T <sub>ST</sub>	—	-20°C	80°C

## 4.BLOCK DIAGRAM MECHANICAL

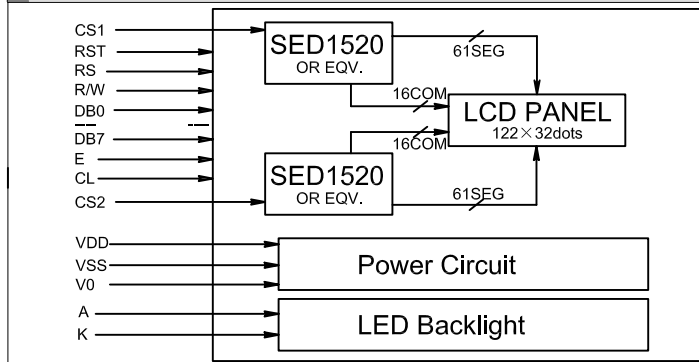

## 5.LED BACKLIGHT SPECIFICATIONS

ITEM	SYMBOL	TYPE	MAX	UNIT
Ta=25°C, yellow-green LED light				
Forward Voltage	V <sub>f</sub>	4.1	4.3	V
Forward Current	I <sub>f</sub>	90	—	mA
Emission Vave Length	λ <sub>P</sub>	572	—	nm

## 6.INTERFACE PIN CONNECTIONS

ITEM	SYMBOL	LEVEL	FUNCTIONS
1	VSS	0V	Power Ground
2	VDD	+5V	Power Supply For Logic
3	V0	—	Contrast ajust
4	A0	H/L	H:data L: instruction data
5	CS1	L	Chip selection for IC1
6	CS2	L	Chip selection for IC2
7	CL	H/L	External clock input
8	E	H/L	Enable Signal
9	R/W	H/L	H:read L:write
10-17	DB0-DB7	H/L	Data Bus
18	RST	H/L	Reset Signal
19	A	5V	Power supply For LED Backlight
20	K	0V	

## 7.ELECTRICAL CHARACTERISTICS

ITEM	SYMBOL	MIN	TYPE	MAX	UNIT
Ta=25°C					
Logic Power	V <sub>DD</sub>	4.5	5	5.5	V
Input High Voltage	V <sub>IH</sub>	2	—	V <sub>DD</sub>	V
Input Low Voltage	V <sub>IL</sub>	0	—	0.8	V
Output High Voltage	V <sub>OH</sub>	2.4	—	V <sub>DD</sub>	V
Output Low Voltage	V <sub>OL</sub>	0	—	0.4	V
Logic Current	I <sub>DD</sub>	—	—	1.5	mA
Operation Voltage For LCD	V <sub>DD-V0</sub>	—	4.8	—	V